



**ARCTIC
RESPONSE
TECHNOLOGY**
OIL SPILL PREPAREDNESS

24 October 2013

I.A. Buist

S.G. Potter

B.K. Trudel, S.L. Ross Environmental Research Ltd.

S.R. Shelnutt, Center for Toxicology and Environmental Health, LLC

A. H. Walker

D.K. Scholz, Scientific and Environmental Associates Inc.

P.J. Brandvik, SINTEF

J. Fritt-Rasmussen, Danish Centre for Environment and Energy

A.A. Allen, Spiltec

P. Smith, Elastec/American Marine

IN SITU BURNING IN ICE-AFFECTED WATERS:

STATE OF KNOWLEDGE REPORT

FINAL REPORT 7.1.1

Report from Joint Industry Programme to present status of regulations related to in situ burning in Arctic and sub-Arctic countries.



ABOUT THE JIP

Over the past four decades, the oil and gas industry has made significant advances in being able to detect, contain and clean up spills in Arctic environments. To further build on existing research, increase understanding of potential impacts of oil on the Arctic marine environment, and improve the technologies and methodologies for oil spill response, in January 2012, the international oil and gas industry launched a collaborative four-year effort – the **Arctic Oil Spill Response Technology Joint Industry Programme (JIP)**.

Over the course of the programme, the JIP will carry out a series of advanced research projects on six key areas: dispersants, environmental effects, trajectory modeling, remote sensing, mechanical recovery and in situ burning. Expert technical working groups for each project are populated by the top researchers from each of the member companies.

JIP MEMBERS

The JIP is managed under the auspices of the International Association of Oil and Gas Producers (OGP) and is supported by nine international oil and gas companies – BP, Chevron, ConocoPhillips, Eni, ExxonMobil, North Caspian Operating Company (NCOC), Shell, Statoil, and Total – making it the largest pan-industry programme dedicated to this area of research and development.

TABLE OF CONTENTS

ABOUT THE JIP	2
JIP MEMBERS	2
LIST OF FIGURES	7
LIST OF TABLES	9
LIST OF ABBREVIATIONS, SYMBOLS AND ACRONYMS	11
GLOSSARY OF KEY TERMS	14
ACKNOWLEDGEMENTS	21
EXECUTIVE SUMMARY	22
CHAPTER 1. INTRODUCTION.....	26
1.1 Objective	26
1.2 Recent Interest in In Situ Burning	26
1.3 Advantages and Operational Issues Associated with In Situ Burning.....	27
1.3.1 Simple Logistics:	27
1.3.2 High Elimination Rates:	27
1.3.3 High Efficiency of Burn:	27
1.3.4 Versatility:	27
1.3.5 Flashback and Secondary Fires:	28
1.3.6 Combustion By-products:	28
1.3.7 Burn residue	28
1.4 Summary of Key Issues	28
1.5 Report Outline.....	29
1.6 Scope of Study	30
References to Chapter 1	31
CHAPTER 2. HISTORY OF IN SITU BURNING AT EXPERIMENTAL AND ACCIDENTAL SPILLS	32
2.1 Introduction	32
2.2 Spills Involving In Situ Burning.....	32
2.3 Chronological History of Burning at Accidental Spills.....	32
References to Chapter 2	40
CHAPTER 3. FATE AND BEHAVIOUR OF OIL SPILLS IN ICE –AFFECTED WATERS	42
3.1 Introduction	42
3.2 Petroleum Oil Characteristics	42
3.2.1 Crude Oil	42
3.2.2 Refined Products.....	44
3.3 Fate and Behaviour.....	44
3.3.1 Oil Spreading	44
3.3.2 Oil Movement	51
3.3.3 Oil Encapsulation and Migration.....	53
3.3.4 Oil Weathering.....	60
References to Chapter 3	66
CHAPTER 4. THE SCIENCE OF IN SITU BURNING	74
4.1 Steady-State Burning Fundamentals.....	74
4.2 Steady-State Oil Removal Rates	76
4.3 The Vigorous Burning Phase.....	82
4.4 Oil Removal Efficiency and Residue Amounts.....	83
4.5 Oil Slick Ignition and Flame Spreading	88

4.5.1	Oil Slick Ignition	88
4.5.2	Flame Spreading.....	90
4.6	Flame Heights and External Radiation.....	95
4.7	Safe Distance from Oil Flame	100
4.8	Effects of Emulsification	102
4.8.1	A Model for Emulsion Burning	107
	References to Chapter 4	109
CHAPTER 5. IN SITU BURNING IN ICE AND SNOW CONDITIONS.....		114
5.1	Introduction.....	114
5.2	Burning Oil on Solid Ice	114
5.2.1	Burning Oil in Snow.....	119
5.3	Burning Oil in Drift and Pack Ice Conditions.....	121
5.4	Burning Accidental Spills in Ice Conditions.....	128
5.5	Summary.....	130
	References for Chapter 5	132
CHAPTER 6. TECHNOLOGY OF IN SITU BURNING.....		135
6.1	Introduction.....	135
6.2	Igniters	135
6.2.1	Brief History of Igniter Development.....	135
6.2.2	Presently Available Ignition Systems.....	137
6.2.3	Fixed-Wing Aerial Ignition System.....	148
6.2.4	Summary of Disused Ignition Systems.....	149
6.3	Fire Resistant Containment Booms.....	154
6.3.1	Brief History.....	154
6.3.2	Presently Available Fire Resistant Booms.....	159
6.3.3	Summary of Disused Fire Resistant Booms	168
6.4	Additives.....	172
6.4.1	Ignition Promoters	173
6.4.2	Combustion Promoters	174
6.4.3	Smoke Suppressants	178
6.5	Herding Agents.....	179
6.6	Floating Burners and Incinerators	182
6.6.1	Pittsburgh Corning Floating Incinerators	183
6.6.2	BP Elijah Burner.....	185
6.6.3	Pipeline Rupture Burner (adapted from Battelle, 1979)	185
6.6.4	Dome Sub-Sea Blowout Burner.....	185
6.6.5	Continuously-Burning Wicking Devices.....	186
6.6.6	Acoustic Burner.....	186
6.6.7	Air Jet Atomizing Burner.....	186
6.6.8	University of Arizona Burners.....	188
6.6.9	Arctic Environment Incinerator Barge.....	190
6.6.10	Radiative Evaporation	191
6.6.11	Testing Augmented In Situ Combustion	191
6.6.12	Technology Assessment and Concept Evaluation for Alternative Approaches to In Situ Burning	192

6.6.13	Research on Combining an Oleophilic Skimmer and Floating Burner for One-Step Offshore Oil Removal	192
	References to Chapter 6	194
CHAPTER 7.	ENVIRONMENTAL AND HUMAN-HEALTH EFFECTS OF UNBURNED OIL SPILLS.....	204
7.1	Fate and Movements of Oil Spills	204
7.1.1	Effects of Presence of Ice on Oil Fate.....	205
7.2	Environmental Effects.....	206
7.2.1	Oil Slicks and Oil Stranded on Shores	206
7.2.2	Oil on Ice, Under Ice, or Among Broken Ice	208
7.2.3	Offshore Water Column and Seabed Effects.....	208
7.2.4	Airborne Oil and Hydrocarbons	209
7.3	Human Health and Safety	209
7.3.1	Oil Slicks and Oil Stranded on Shorelines.....	209
7.3.2	Dissolved/Dispersed and Sedimented Oil	209
7.3.3	Airborne Hydrocarbon Plume.....	211
7.4	Summary.....	219
	References to Chapter 7	221
CHAPTER 8.	REVIEW OF ENVIRONMENTAL AND HUMAN-HEALTH EFFECTS OF IN SITU BURNING.....	224
8.1	Introduction.....	224
8.2	Methods.....	224
8.2.1	Technical Subjects	224
8.2.2	Information Sources and Approach	224
8.3	Behaviour, Fate and Environmental Effects of Burn Products and Residue	224
8.3.1	Aquatic.....	225
8.3.2	Airborne Emissions	229
8.4	Human Hazards and Health Effects.....	234
8.4.1	Physical Hazards.....	234
8.4.2	Air Quality and Inhalation	234
8.4.3	Water Column and Ingestion.....	242
8.4.4	Dermal Contact.....	242
8.4.5	Other Effects and Impacts	242
8.4.6	Summary.....	242
	References to Chapter 8	243
CHAPTER 9.	RISK EVALUATION OF THE ACCEPTABILITY OF BURNING SPILLED OIL	247
9.1	Objective	247
9.2	Description of Assumptions Supporting Risk Evaluation	247
9.3	Chemical and Physical Properties of Oil and Combustion Products	247
9.3.1	Crude Oil Characteristics	247
9.3.2	Oil Spill Behaviour	248
9.3.3	Chemical Properties of Crude Oil Combustion Products	248
9.4	Human Health Risk Evaluation.....	249
9.4.1	Introduction.....	249
9.4.2	Human Exposure Pathways.....	250
9.4.3	Chemicals of Concern for Health Risk Assessment	250
9.4.4	Toxicity Assessment	255
9.4.5	Risk Assessment.....	259

9.4.6	Conclusions	263
9.5	Ecological Risk Evaluation.....	263
9.5.1	Exposure Assessment.....	263
9.5.2	Chemicals of Concern for Ecological Risk Evaluation	271
9.5.3	Relative Risk Evaluation.....	273
9.6	Human and Ecological Factors Important to a Burn/No- Burn Decision.....	273
9.6.1	Health Risks from Unburned Oil Spills	273
9.6.2	Health Risks from Exposure to PM in Burn Emissions	274
9.6.3	Health Risks from Toxic and Carcinogenic Compounds in Burn Emissions	274
9.6.4	Risk Associated with Burn Residue.....	274
9.6.5	Risks from Oil Burning	274
	References to Chapter 9	275
CHAPTER 10. OPERATIONAL CONSIDERATIONS.....		277
10.1	Introduction	277
10.2	Feasibility of Burning	277
10.2.1	Oil Type and Condition.....	278
10.2.2	Slick thickness	279
10.2.3	Environmental Constraints.....	280
10.2.4	Compatibility with other Response Activities.....	282
10.2.5	Requirement for Regulatory Approvals	284
10.3	Resources Necessary for a Burn	284
10.3.1	Trained Personnel.....	284
10.3.2	Vessels and Aircraft	285
10.3.3	Fire Booms	287
10.3.4	Igniters	288
10.3.5	Avoidance of Risk to People and Property.....	288
10.4	Safety and Control Measures.....	289
10.4.1	Burn Plan:	289
10.4.2	Training:.....	290
10.4.3	Communications:.....	290
10.4.4	Fire Control:	290
10.4.5	Aerial Surveillance:	290
10.4.6	Traffic Control:	291
10.4.7	Personnel Protection:	291
10.5	Recovery of Burn Residue	292
10.6	Possible Mitigation Efforts	292
10.6.1	Burn and Plume Location:.....	292
10.6.2	Minimization of Burn Time:.....	292
10.6.3	Use of Ignition Enhancement Techniques:.....	292
	References to Chapter 10	293

LIST OF FIGURES

Figure E-1 Map showing experimental spills and actual incidents involving burns in ice 23

Figure E-2 Timeline of experimental spills and actual incidents involving burns in ice 24

Figure 3-1 Illustration of Oil and Ice Processes 45

Figure 3-2 Predicted Spreading of Spilled Oil on Ice 46

Figure 3-3 Predicted Radii of Spills of a Given Volume Spilled Under Landfast Ice 48

Figure 3-4 Predicted Spreading of Spills on Open Water..... 51

Figure 3-5 Oil encapsulated in a 1.5-m thick slab of sea ice excavated from an experimental spill in Alaska. 54

Figure 3-6 Initial Surface Appearance of Crude Oil Migrating Through the Ice at the Dome Oil and Gas Under Sea Ice Experiment in Early June 1980..... 56

Figure 3-7 Rate of Oil Exposure From Beneath Sea Ice Originating From Three Simulated Sub-sea Blowouts 57

Figure 3-8 Estimated Amount of Oil Penetrated Through the Brine Channels in the Ice and Available on the Ice Surface during SINTEF’s Experimental Spill Under Ice in 2006 Photos show appearance of cores at different stages in the migration cycle..... 58

Figure 4-1 Key heat and mass transfer processes for in situ burning 74

Figure 4-2 Burning data 77

Figure 4-3 Burning rate vs. fire diameter - a comparison of data sets. 77

Figure 4-4 Relationship between burning rate and tank diameter..... 78

Figure 4-5 Development of the vigorous burning phase. 82

Figure 4-6 Effect of oil layer thickness on mass loss rate (fuel) for crude oil fires 84

Figure 4-7 Residue thickness as a function of initial slick thickness..... 85

Figure 4-8 Removal efficiency vs. wind speed for 1m² burns 86

Figure 4-9 Heat transfer and convective motion during slick ignition..... 89

Figure 4-10 Relationship between the liquid temperature and the rate of plane flame spread of methanol in a vessel 2.6-cm wide and 1.0-cm deep..... 91

Figure 4-11 Schematic representation of the spreading flame..... 92

Figure 4-12 The flame spreading rate across thickened kerosene surfaces at room temperature (21°C) as a function of viscosity..... 93

Figure 4-13 Flame spreading velocity 94

Figure 4-14 Flame height vs. fire diameter - a comparison of data sets 97

Figure 4-15 Flame deflection angle as a function of the kinematic Froude number 99

Figure 4-16 External heat flux from burning..... 100

Figure 4-17 Allowable fluxes for personnel exposure..... 101

Figure 4-18 W/O emulsion fire points vs. water content..... 106

Figure 4-19 Key heat and mass transfer processes for in situ burning of emulsions..... 108

Figure 5-1 Burn of oil in melt pools at Balaena Bay, NWT 1975. 115

Figure 5-2 Burning crude oil from a subsea blowout under ice..... 117

Figure 5-3 Burning crude oil on ice at -31.5°C 117

Figure 5-4 Igniting emulsions on water on ice with modified igniters 118

Figure 5-5 Burning oiled snow in volcano-shaped piles 120

Figure 5-6 Burning a diesel spill in snow on ice 120

Figure 5-7 Burning oiled snow in a portable air-curtain incinerator 121

Figure 5-8 Burns in broken ice at East Dock, Prudhoe Bay, AK, 1983 122

Figure 5-9 Burning crude oil in 9+/10ths pack ice off Cape Breton, 1986 123

Figure 5-10 Burning oil in brash ice with waves at Svalbard 1992..... 124

Figure 5-11	Test burns in brash ice with waves in Prudhoe Bay, 2003.....	125
Figure 5-12	Burning oil weathered in brash ice in meso-scale burn pit at Svalbard, 2007	127
Figure 5-13	Burning 2 m ³ experimental spill in pack ice on the Barents Sea 2009.....	127
Figure 5-14	Test with 3 to 5/ 10 th small floes.....	128
Figure 5-15	Test with brash and slush ice	128
Figure 5-16	Map showing experimental spills and actual incidents involving burns in ice.	131
Figure 5-17	Timeline of experimental spills and actual incidents involving burns in ice.	131
Figure 6-1	Safe Start hand-held igniter	138
Figure 6-2	AFTI Hand-held Igniter.....	139
Figure 6-3	Basic design and internal components of the Dome or Energetex igniter	141
Figure 6-4	Heli-Torch Components and Support System	144
Figure 6-5	Environmental Protection Service (EPS) igniter, or Pyroid igniter, showing internal firing mechanism and pyrotechnic components.....	150
Figure 6-6	Concept for use of herders to contract oil slicks in drift ice for ignition and burning.	180
Figure 6-7	Burn test with ThickSlick 6535 at Prudhoe Bay, AK in 2006.....	181
Figure 6-8	Burn of herded slick in Barents Sea pack ice lead	182
Figure 6-9	Testing of silicone-based herding agents at CRREL.....	182
Figure 6-10	Floating oil spill furnace	183
Figure 6-11	Oil spill incinerator vessel.....	183
Figure 6-12	BP "Elijah" burner during tests.....	185
Figure 6-13	Combustion system for pipeline leaks.....	185
Figure 6-14	Dome subsea blowout burner	187
Figure 6-15	Wicking burner.....	187
Figure 6-16	Combination of oil herding and atomizing device	187
Figure 6-17	Sprayburn floating oil burner.....	187
Figure 6-18	Sketch of burn pool with vanes and compressed air supply - front four vanes not shown	188
Figure 6-19	Two-metre diameter incinerator.....	189
Figure 6-20	Conceptual sketch of seagoing incinerator.....	190
Figure 6-21	General arrangement of Arctic incinerator barge.....	190
Figure 6-22	Burn test with no aeration	191
Figure 6-23	Burn test with compressed air nozzle aeration.....	191
Figure 6-24	Simple, modified existing barge hull concept	192
Figure 6-25	Purpose-built barge with enhanced combustion air	192
Figure 6-26	Small-scale floating burner test in an indoor wave tank.....	193
Figure 6-27	Mid-scale burner model during outdoor tests.....	194
Figure 8-1	Aspects of burning oil on water and pathways for spill and burn products into the environment	226
Figure 8-2	Particle size distributions in smoke plumes from large in situ burns.....	231
Figure 9-1	Ecological conceptual site model of offshore, ice-free environment.	266
Figure 9-2	Ecological conceptual site model of an ice-affected offshore environment.....	267
Figure 9-3	Ecological conceptual site model of an ice-free nearshore environment	268
Figure 9-4	Ecological conceptual site model of ice-infested, nearshore environment	269

LIST OF TABLES

Table 2-1: Summary of In Situ Burning: Tests and Use on Spills on Water and in Ice Conditions 33

Table 3-1: Chemical Composition of Three Crude Oils 43

Table 3-2: Spreading comparison for a 1600 m³ (10,000 bbl) crude oil spill..... 46

Table 4-1: Data for Large-Pool Burning Rate Estimates* 80

Table 4-2: Summary of In-situ Burning Rates for Unemulsified Oil Spilled On Water 81

Table 4-3: Dependence of Q on D for crude oil fires 97

Table 4-4: Height increases during vigorous burn phase 98

Table 4-5: Calculated Safe Approach Distance to In-Situ Oil Fire 101

Table 4-6: Predicted Oil Burn Rates* for Large In-Situ Crude Oil Emulsion Burns..... 103

Table 5-1: Distribution of average oiled melt pool sizes – 1980, McKinley Bay, NWT 116

Table 6-1: Summary of Igniter Characteristics and Performance 146

Table 6-2: Summary of Fire Boom System/Component Propane Flame Tests at Ohmsett 157

Table 6-3: Desmi-AFTI Pocket Boom 160

Table 6-4: American MKII Fire Boom 162

Table 6-5: Elastec American Marine Hydro-Fire Boom 165

Table 6-6: Desmi-AFTI Pyroboom 167

Table 7-1: Health-based criteria for PAHs in seafood (from White, 2011) 210

Table 7-2: Workplace Exposure Standards for vapours of Oil and Petroleum-Derived Hydrocarbons..... 216

Table 8-1: More abundant smoke components^a..... 229

Table 8-2: Air Quality Standards..... 230

Table 8-3: Safe approach distances for in situ burns (from Chapter 4) 234

Table 8-4: Levels of selected chemicals found in air samples approximately 200-m above the DWH spill region on June 10^a 235

Table 8-5: Comparison of Criteria Pollutant Ambient Standards (U.S. EPA, 2012; CCME, 1999; European Commission, 2012) 236

Table 8-6: Comparison of Action Levels and Associated Recommendations for Particulate Matter Associated with Wildfires (from OEHHA, 2008; U.S. EPA, 1999; Schwela *et al.*, 1999)..... 238

Table 8-7: Simplified tabular results of the ALOFT FT and ALOFT CT Soot Dispersion Models..... 239

Table 8-8: ALOFT Models adjusted for PM10 Soot Target Concentration / Particle Size 240

Table 8-9: ALOFT Models adjusted for PM2.5 Soot Target Concentration / Particle Size 241

Table 9-1:	Chemical Composition of Three Crude Oils*	248
Table 9-2:	Emission Factors for Airborne Chemicals from an In Situ Burn	249
Table 9-3:	Concentrations of N-Paraffins and Aromatic Hydrocarbons in Crude Oils in ppm	251
Table 9-4:	Concentrations of Carcinogenic and Noncarcinogenic PAHs (Vapour and Particulate) Produced by Combustion of Alberta Sweet Crude Oil ¹ (µg of PAH/g of sample).....	253
Table 9-5:	Modeled Maximum 24-Hour Air Concentrations of Criteria Pollutants Compared with Ambient Standards, µg/m ³	255
Table 9-6:	Toxicity Factors for PAHs	257
Table 9-7:	Relative Potency Estimates for Carcinogenic PAHs.....	258
Table 9-8:	Summary of Conceptual Site Model Assessments	270
Table 9-9:	Solubilities and Partition Coefficients for Polynuclear Aromatic Hydrocarbons	271
Table 10-1:	Summary of tactics for a range of ice conditions	280

LIST OF ABBREVIATIONS, SYMBOLS AND ACRONYMS

ACGIH	American Conference of Industrial Hygienists
ACS	Alaska Clean Seas
ADAF	Age-dependent Adjustment Factors
AEGL	Acute Exposure Guideline Levels
AIHA	American Industrial Hygiene Association
AMOP	Arctic and Marine Oilspill Program
ANS	Alaska North Slope Crude
API	American Petroleum Institute
ARRT	Alaska Regional Response Team
ASMB	Albert Sweet Mixed Blend
ATSDR	Agency for Toxic Substances and Disease Registry
AUV	Autonomous Underwater Vehicle
BaP	Benzo(a)pyrene
BBL	Barrel
BFs	Slope Factors
BP	Boiling Point
BSEE	Bureau of Safety and Environmental Assessment
BTEX	Benzene-toluene-ethylbenzene-xylene
CAS	Chemical Abstracts Service (Registry)
cP	Centipoise
CDC	Centers for Disease Control and Prevention
CRRL	U.S. Army Cold Regions Research and Engineering Laboratory
CSM	Conceptual site model
cSt	Centistoke
DOE	U.S. Department of Energy
DREV	Defence Research Establishment at Valcartier
DWH	Deepwater Horizon
EC	European Commission
EFV	Equilibrium Flash Vaporization
EPA	Environmental Protection Agency (U.S.)
EPS	Environmental Protection Service (Canada)
ERPG	Emergency Response Planning Guide
EU	European Union
FAA	Federal Aviation Administration
FDA	Food and Drug Administration
HAZWOPER	Hazardous Waste Operations and Emergency Response
HBP	Highest Boiling Point
HC	Heavy Components
HI	Hazard Index

HQ	Hazard Quotient
HFO	Heavy Fuel Oil
IFO	Intermediate Fuel Oil
IRIS	Integrated Risk Information Systems (EPA)
ISB	In situ Burn(ing)
LBP	Lower-boiling Point
LC50	Lethal Concentration of 50 percent of the test organism
LEL	Lower Explosive Limit
LMW	Low Molecular Weight
MDO	Marine Diesel Oils
MGO	Marine Gas Oils
MMS	Minerals Management Service
MSRC	Marine Spill Response Corporation
MDO	Marine Diesel Oil
MGO	Marine Gas Oil
N	Newton
NAAQS	National Ambient Air Quality Standard
NAS	National Academy of Sciences
NCP	National Oil and Hazardous Substances Pollution Contingency Plan
NEBA	Net Environmental Benefit Analysis
NIOSH	National Institute for Occupational Safety and Health
NIST	National Institute of Standards and Technology (U.S.)
NOAA	National Oceanic and Atmospheric Administration
NOBE	Newfoundland Offshore Burning Experiment
NRC	National Research Council
OD	Odds Ratio
OEHHA	(California) Office of Environmental Health Hazard Assessment
OGP	International Association of Oil & Gas Producers
OD	Odds Ratio
OHMSETT	Oil and Hazardous Material Simulated Test Tank
OHMT	Office of Hazardous Materials Transportation
OR	Odds Ratio
OSHA	Occupational Safety and Health Administration
OSIR	Oil Spill Intelligence Report
PAHs	Polynuclear (or polynuclear) aromatic hydrocarbons
PCBs	Polychlorinated biphenyls
PEL	Permissible Exposure Limit
PEL-C	Permissible Exposure Limit - Ceiling
PM	Particulate matter
PPB	Parts per billion
PPBV	Parts per billion volume

PPM	Parts per million
PPT	Parts per thousand
REL	Recommended Exposure Limit
REL- C	Recommended Exposure Limit- Ceiling
RfDs	Reference Doses
SCAPA	Subcommittee on Consequence Assessment and Protection Action
SF	Slope Factor
SG	Specific Gravity
STEL	Short-Term Exposure Limit
SWEPI	Shell Western Exploration and Production, Inc.
TEEL	Temporary Emergency Exposure Limit
TEQ	Toxic Equivalency
TPH	Total petroleum hydrocarbons
TLV	Threshold Limit Value
TLV-C	Threshold Limit Value – Ceiling
TWA	Time weighted average
URF	Unit Risk Factor
USCG	U.S. Coast Guard
VOCs	Volatile organic compounds
VRF	Visual Flight Rules
WAF	Water Accommodated Fraction
WHOI	World Health Organization

GLOSSARY OF KEY TERMS

Ablation is the natural melt of snow and ice from an ice surface downwards through various processes, including evaporation, temperature increase, and wind erosion. Ablation can refer either to the process of removing ice and snow or to the quantity of ice and snow removed.

Accelerant is an agent used to promote ignition or spreading of a fire, such as gelled gasoline, diesel/gasoline mixes, and fuel-soaked rags.

Acute Toxicity is a measure of the potential of a material (e.g., oil, chemicals) to cause adverse effects in an organism after only a short period of exposure (generally less than 4 days) relative to its life cycle length.

Advection is a transport process for spills on water where surface slicks are conveyed by water currents. Advection tends to be a combination of current movement and wind-induced surface movements.

Ambient Conditions are those in an environment, such as ambient temperature, humidity, etc. For example, if an oil slick is at or above the temperature of its flash point, the slick will ignite rapidly and easily. If the ambient temperature is below the flash point for the spilled oil, the slick may be difficult to ignite.

API Gravity (API) is a scale for measuring fluid specific gravities based on an inverse relationship with specific gravity (SG). This scale was primarily developed to expand the scale for specific gravity so that larger values are used. An oil with a low specific gravity (e.g., gasoline; SG = 0.73) will have a high API gravity (API = 62).

$$\text{API gravity} = (141.5/\text{SG at } 15.5^{\circ}\text{C}) - 131.5$$

Aromatic Hydrocarbons are composed solely of carbon and hydrogen atoms in various arrangements that include at least one benzene ring. Aromatic hydrocarbons give oil its smell.

Barrel (bbl) is equal to 42 United States gallons at 15.5°C.

Benthic pertains to the bottom of a body of water or organisms which live on or near it.

Benzene, Toluene, Ethyl Benzene and Xylene (BTEX) Compounds are volatile organic compounds which are present in light refined products and crude oils. Their presence after a burn would indicate incomplete combustion of some of the oil.

Biodegradation is the process where naturally occurring bacteria and other micro-organisms consume hydrocarbons as a food source.

Boom are floating barriers used for the collection, diversion, deflection, and containment of spreading liquids.

Brackish is an intermediate salinity range for water bodies where the portion of salt water is greater than fresh (0.50 to 17.00 parts per thousand).

Brash Ice is defined as accumulations of floating ice fragments not more than 2-m across. Brash ice is common between colliding floes or in regions where pressure ridges have collapsed.

Broken Ice is an older term used to describe an ice sheet that is not continuous. It has been replaced by the more descriptive terms pack ice, drift ice, etc.

Burning Agents means those additives which, through physical or chemical means, improve the combustibility of the materials to which they are applied.

Burn Efficiency, is usually expressed as the percent reduction in original oil weight following combustion. It is a function of three main factors: initial slick thickness; thickness of residue at the extinction of the burn; and the aerial coverage of the flame.

Burn Residues is the unburned oil or incomplete combustion products remaining on land, water, snow or ice surface when a fire extinguishes. Residues can range from brittle stiff, taffy-like material, to a liquid similar to the original oil.

Carbon Monoxide (CO) is a common by-product of incomplete combustion.

Centipoise (cP) a unit of measurement for dynamic viscosity.

Centistoke (cSt) a unit of measurement for kinematic viscosity.

Chemical Treating Agents are products used in treating oil spills, including dispersants, bioremediation agents (nutrient additions), herding agents, emulsion treating agents, solidifiers, elasticity modifiers, surface washing agents, and miscellaneous oil spill control agents.

Chronic Toxicity is a measure of the potential of a material to cause an adverse effect in organisms exposed to the contaminant for a significant portion of its life cycle.

Combustion By-Products include the smoke plume constituents and any incomplete burn combustion products remaining after a burn is extinguished (residue).

Containment is the use of boom, herding agents, natural barriers on land, or ice, to constrain and/concentrate the oil slick.

Controlled Burn is combustion that is started and stopped by human intervention.

Convective Motion is flow of a fluid induced by temperature differences.

Density of the oil is a measure of how heavy a specific volume of a solid, liquid, or gas is in comparison to water. The greater the density of a resultant burn residue, the more likely it is to sink.

Effectiveness / Efficacy is the ability to produce the desired outcome

Emulsification is the process of mixing water droplets into the spilled oil forming highly viscous mixtures that have reduced weathering capabilities and are usually more difficult to burn, disperse, and mechanically recover.

Emulsion for spill response purposes is the suspension of water in an oil slick which then alters its appearance, behaviour, fate, and impacts recovery and treatment options. Water-in-oil emulsions may contain 20% - 80% water. Emulsions may be temporary or permanent.

Emulsion Breaker is an emulsion treating agent that breaks an emulsion into separate oil and water phases.

Emulsion Inhibitor is an emulsion treating agent that, if applied to spilled oil before emulsification occurs, limits emulsion formation.

Emulsion Treating Agent is a product that breaks or prevents water-in-oil emulsions by modifying the properties of the oil-water interface to inhibit or destabilise water-in-oil emulsions.

Encapsulation is the process of oil on the underside of a growing ice sheet being enclosed into the ice by the downward growth of ice crystals.

Encounter Rate refers to the amount of oil which comes into contact with a containment and recovery device (e.g., boom, skimmer, sorbents) or is treated (i.e., burned, dispersed) over a given period of time.

Evaporation is the preferential transfer of light-and medium-weight components of an oil from the liquid phase to the vapour phase. Evaporation is typically the most dominant weathering process (oil type and spill location dependent).

Fire Diameter is the horizontal distance from one side of a fire to the opposite side, through the centre of the fire.

Fire Point is the temperature of a fuel at which it will continue to burn for at least 5 seconds after ignition by an open flame.

Flammability limit is the range of concentration of flammable vapours in air that will ignite.

Flame Deflection Angle is the average angle from vertical that wind bends a flame.

Flash Point is the lowest temperature at which the vapour of a flammable liquid will ignite in air. The flash point is generally lower than the temperature needed for the liquid itself to ignite. A substance may ignite briefly, but vapour may not be produced at a rate to sustain a fire. In general a fire point can be assumed to be about 10°C higher than the flash point for a given material.

Frazil Ice is a collection of loose, randomly oriented needle-shaped ice crystals in water. It resembles slush and has the appearance of being slightly oily when seen on the water. It usually forms in rivers, lakes and oceans, on clear nights when air temperature reaches -6°C or lower. Frazil ice is the first stage in the formation of sea ice.

Fresh / Freshwater is a classification of waterbody by its low salinity less than 0.5 parts per thousand.

Gelling Agent is a chemical thickener which, when mixed with oil, turns the mixture into a solid or gel.

Gelled Gasoline is a gasoline/diesel mixture formed by adding a chemical thickener to gasoline. Thickeners include aluminum soaps, wax, tallow, etc.

Heat Flux is the total amount of heat radiated, convected and conducted away from a fire per unit time.

Herding Agent is a product which contracts a liquid (in this case an oil slick) on a water surface by exerting a higher spreading pressure than the oil slick.

Hydrophilic is Latin for “water loving” and means a material mixes easily or easily dissolves into water.

Hydrophobic is Latin for “water fearing” and means material does not mix well or dissolve well into water. Oils are typically hydrophobic.

Ice-affected waters are those that have ice in some form on their surface.

Ignition Sources/Igniters are devices designed to provide heat to a material and increase its temperature to its Fire Point and provide an ignition source. Commonly used ignition devices include propane or butane torches, gelled fuel with an attached flare, diesel-soaked rags or sorbents, helicopter-slung gelled fuel (Helitorch), and road flares.

Ignitable Thickness means in general, the thickness of oil necessary to generate sufficient vapours to enable ignition.

Immiscible Liquids do not mix with each other.

In Situ Burning (ISB) is the controlled combustion/burning of spilled oil in place such that the petroleum hydrocarbons are predominantly converted to CO₂ and water which are released to the atmosphere. (see also Controlled Burning).

Interfacial Tension is the tendency of a liquid surface, in contact with an immiscible liquid, to contract. The imbalance of forces at the liquid-liquid interface is due to the difference in molecular forces in the two immiscible liquids.

Intertidal is the part of a shoreline between the highest and lowest tide levels.

LC₅₀ or LC50 is the concentration of a product that causes 50 percent mortality to the test organism over a stated period of time. Length of exposure is usually 24 to 96-hours.

Lipophilic is Latin for "lipid loving" and means substances mix well or dissolve easily into oils, lipids and fats.

Marine or Saltwater is a classification of waterbody based on salinity. It is sometimes used synonymously with ocean, but reflects a broader salinity range from 17 parts per thousand and up.

Microbial Degradation is a naturally occurring process where micro-organisms consume petroleum hydrocarbons as a food source. (see biodegradation).

Miscible is the ability of one liquid to be mixed at any ratio, into a second liquid without separation of the two liquids.

Natural Dispersion is the process of breaking waves forcing oil droplets into the water column, which can result in at least a portion of the droplets small enough to remain in the water.

Net Environmental Benefit Analysis (NEBA) is the comparison of environmental and socio-economic outcomes of selected spill scenarios using various response options against a baseline, whose results are used in contingency planning stages and during a response to inform decision-making as to those options with the least negative effects. In this context, the baseline for comparison is slick monitoring and observation only, while response options can include mechanical only, mechanical and dispersants, dispersants only, ISB, etc. The NEBA process is typically used when a response option other than mechanical recovery alone, and especially for on-water spill scenarios, is desired.

Nitrogen Dioxide (NO₂) is a gaseous by-product of oil combustion.

Oil means oil of any kind of petroleum hydrocarbon, in particular those in liquid form which could be spilled.

Oleophilic, is Latin for "oil loving" and means a substance, mixes well with or easily dissolves into oil.

Particulates are very small pieces of solid materials (e.g. dusts, soot, fumes) or liquid material (mists, fogs, sprays) that remain suspended in the air long enough to be inhaled.

Particulate Matter (PM) refers to particulates with a size range that are judged to be more easily inhaled and can enter lungs at 10 micrometers in diameter or smaller. Particulate matter is often grouped into two categories:

1. (PM10) is a coarser mixture of solid and liquid droplets (up to 10 microns in diameter).
2. (PM2.5) are particles less than 2.5 micrometers in diameter are called "fine" particles. These particles are so small they can be detected only with an electron microscope. Sources of fine particles include all types of combustion, including motor vehicles, power plants, residential wood burning, forest fires, agricultural burning, and some industrial processes.

Parts Per Billion (ppb) is a unit of concentration. One ppb is roughly equivalent to one teaspoon in 1,300,000 gallons.

Parts Per Million (ppm) is a unit of concentration. One ppm is roughly equivalent to one teaspoon in 1,300 gallons.

Parts Per Thousand (ppt) is a unit of concentration. One ppt is roughly equivalent to one teaspoon in 1.3 gallons.

Persistence is a means of defining how crude and refined oil products may remain in the environment. Persistent oils may not be completely removed from an affected environment as a result of weathering processes or clean-up operations.

Photo-Oxidation is the process by which components in an oil are chemically transformed through a photo-chemical reaction (in the presence of atmospheric oxygen) to produce compounds which tend to be both more water soluble and acutely toxic (in the near term) than the parent compounds.

Polynuclear Aromatic Hydrocarbons (PAHs) are a group of hydrocarbons compounds characterized by multiple benzene rings, very low vapour pressures, and relatively low flammability (compared to other compounds found in crude oils). PAHs are found in unburned oil as well as in smoke plumes.

Polynya or Polynia is an area of open water surrounded by sea ice; it is also a geographical term for areas in the Arctic which remain unfrozen for much of the year.

Pour Point is the temperature below which oil will cease to flow in a specified test apparatus and from a spill response perspective means an oil is transitioning from a liquid to a solid.

Primers, also known as Ignition Promoters are substances (usually combustible liquids) which enable flames to spread across the surface of a slick that otherwise flames would not naturally spread across.

Promoters, also known as Combustion or Burn Promoters, are substances (often sorbent-like solids or powders, or wicking agents) which promote more efficient removal of hard-to-burn slicks by their wicking action and/or insulating a slick from cooler underlying water.

Salinity is a measure of the relative concentration of salt in a solution, such as water. Usually measured as ppt. Ocean water is typically 35-36 ppt.

Sedimentation is one of the weathering processes. It is the transferal of oil adsorbed from a water surface to a seafloor or shoreline. Oil droplets can attach to suspended solids in the water column and sink or oil stranded on shore may become mixed with the shoreline sediments and sink to the sea floor.

Sheen is a very thin layer of floating oil, less than 0.0003mm in thickness. Sheen may appear as silver (0.00007-mm), rainbow (0.00015-mm) or gray (0.001-mm), depending on thickness, sheens range in colour from dull brown for the thickest sheens to rainbow, grays, silver, and near-transparency in the case of the thinnest sheens.

Slick is a thin layer of spilled oil.

Solidifier is a product which mixes with oil to turn it into a rubber-like solid.

Soluble / Solubility is the relative ability of one material to dissolve in another. A product is considered "quite soluble" in water if its solubility is greater than 1 ppt. A product is considered "sparingly soluble" in water if its solubility is between 1 ppt and 1 ppm. A product is considered "very sparingly soluble" in water if its solubility is between 1 ppm and 1 ppb. A product is considered "essentially insoluble" in water if its solubility is 1 ppb or less.

Sorbent is any oleophilic material which is used to take up oil through absorption or adsorption. Essentially made from inert and insoluble materials that are used to remove oil and hazardous substances from water through adsorption, in which the oil or hazardous substance is attracted to the sorbent surface and then adheres to it; or by absorption, in which the oil or hazardous substance penetrates the pores of the sorbent material; or a combination of the two.

Specific Gravity (SG) is the ratio of the mass of a material (e.g., oil) to the mass of freshwater, for the same volume and at the same temperature. Most crude oils and refined products have specific gravity values between 0.78 and 1.00. If the SG of an oil is less than the SG for a surface water (freshwater (SG) is = 1.0 at 4°C; seawater (SG) is = 1.03 at 4°C), then the oil will float on the water surface.

Spreading is the dominant transport process for most oil spills, whether on water, on land, or in ice/snow. Spreading occurs due to surface tension and/ gravity.

Spreading Pressure is the force exerted against a fixed barrier as a liquid is compressed into a smaller surface area.

Substrate is the substance or base on which, or the medium in which, an organism lives and grows, or the surface to which a fixed organism is attached; e.g., soil or rocks.

Sub-Tidal is the part of the coastal zone that lies below the lowest low tide level, so that it is always underwater.

Sulfur Dioxide (SO₂) is a gas formed when sulfur in an oil or hydrogen sulfide oxidizes during combustion.

Surface Collecting Agents are those chemical agents which form a surface film to control the layer thickness of oil. (see herding agent).

Surface Tension is the tendency of a liquid surface, in contact with air, to contract due to an imbalance of forces on the molecules in the bulk liquid versus those at the surface in contact with air.

Surfactant, also referred to as surface-active agent, is a chemical which contains both oil-soluble and water-soluble components

Toxicity is the inherent potential or capacity of a material (e.g., oil, chemicals) to cause adverse effects in a living organism.

Trace Metals in oil consist primarily of Nickel, Iron, Vanadium, Copper, and Arsenic.

Viscosity is the resistance to flow and may be reported in one of two ways for oil spills. Dynamic viscosity (μ) refers to internal friction of a substance (e.g., oil) that is a function of the oil type and temperature and is measured in Centipoise units (cP). The lower the viscosity, the thinner the fluid (e.g., water = 1 cP, molasses = 100,000 cP). Kinematic viscosity (ν) is a given fluids dynamic viscosity divided by its density, is measured in Stoke (St) units and is often reported in centistoke (cSt). Since the density of oil is not too different from water, rough estimates of dynamic and kinematic viscosities are similar.

Volatility is the tendency for the components in a liquid to vapourise.

Volatile Organic Compounds (VOCs) are a mixture of the lighter, Low Molecular Weight (LMW) hydrocarbons, including benzene. During any spill, the lighter, more volatile components evaporate more quickly, and much slick volume can be lost from within the first 24–48-hours.

Water Column is an imaginary cylinder or box from the surface of the water to the bottom.

Weathering is the process of alteration of physical and chemical properties of a material through natural processes, including spreading, evaporation, dissolution, photo-oxidation, emulsification, sedimentation, and biodegradation.

Window of Opportunity is an interval of time during which conditions are favorable and an opportunity exists for a spill response option to be implemented effectively.

ACKNOWLEDGEMENTS

The authors would like to thank the JIP members for funding this project. The Principals of the JIP are currently:

- BP Exploration Operating Company
- Chevron Canada Limited
- ConocoPhillips Corporation
- Eni E & P
- ExxonMobil Joint Research Limited
- North Caspian Operating Company
- Shell International Exploration and Production BV
- Statoil Petroleum AS
- Total E & P Recherche Development

The Technical Director for OGP was Dr. John Campbell. The JIP Project Manager was Mr. Joseph Mullin.

EXECUTIVE SUMMARY

This report is a synthesis of the current state of knowledge on the subject of oil spill in situ burning as an oil spill response countermeasure in ice-affected waters. It is organized in such a way as to allow researchers, specialists, and interested, stakeholders to access the science and technology behind in situ burning in a logical and sequential manner. This report has been compiled from a literature review, as well as practitioner knowledge, field tests, and response experience.

In situ burning is a countermeasure that has rarely been used on marine oil spills, but its successful use during the Gulf of Mexico *Deepwater Horizon* response increased interest in further investigating its potential value as a technique to manage spilled oil. In 2010, controlled burning of spilled oil with fire booms eliminated between 220,000 and 310,000 barrels of oil that could have otherwise reached shorelines and other sensitive resources in the Gulf of Mexico. Between April 28th and July 19th, 2010, over 400 burns were initiated. Burns continued throughout this period in daily-approved ISB Burn Areas, typically within 3 to 15 miles of the *Deepwater Horizon* spill source.

In situ burning has been considered a viable, primary spill response option for oil spills in ice-affected waters since offshore drilling began in the Beaufort Sea in the 1970s. Field trials at that time demonstrated on-ice burning of spilled oil offered the potential to remove almost all of the oil present on an ice surface with only minimal residue. Since then, a great many studies and trials have been undertaken to investigate and document burning of crude oil slicks (both fresh and emulsified) in cold open water, slush ice, drift ice, pack ice and on solid ice. **Figure E-1** is a map showing the locations of all the experimental and actual burns in ice-affected waters that have occurred worldwide since 1958. **Figure E-2** shows the timeline for the burns. Laboratory and field experiments spanning the past 40+ years have led to a good understanding of the science of burning under a variety of ice conditions and the importance of such factors as: minimum ignitable slick thickness for various oil types and states of weathering, wind and wave limits for successful burning, and the maximum water, ice and snow contents that can be tolerated for a successful burn.

The behaviour of oil spilled in ice covered waters largely dictates whether in situ burning is possible for a given spill, and is governed principally by the ice concentration in the case of drift or pack ice and the processes of encapsulation and subsequent migration in the case of consolidated or fast ice. Each season presents different drawbacks and opportunities for in situ burning. During freeze up and breakup, drifting ice and limited site access tend to restrict possible response options and can reduce removal effectiveness. Mid-winter, although associated with long periods of darkness and cold temperatures, provides a stable ice cover that not only naturally contains oil within a relatively small area but also provides a safer working platform for surface oil removal. For spills under or on fast ice, there are a range of effective burning options which can result in very high removal effectiveness. Options to deal with spills in moving pack ice are more limited and likely to result in highly variable removal values depending on a variety of natural conditions and logistics constraints. In these conditions it is often only possible to track the oil until it is released from the ice the following spring and ignite and burn it then.

This report includes a treatise on the science of how in situ oil burning works, consisting of a detailed literature review of all relevant scientific and field studies and experiments on the subject. The key physical and chemical processes involved in in situ burning are discussed, as

well as the factors that control ignitability and combustibility of oil spills on water. Also discussed in detail is how various oil weathering processes, such as water-in-oil emulsification, affect ignition and burning.



Figure E-1 Map showing experimental spills and actual incidents involving burns in ice.

- | | |
|--|---|
| A: USCG experiments near Barrow, AK, 1971-72 | 1: Pipeline Spill, Near Normal Wells, Mackenzie River, Canada, 1958 |
| B: Experiments by McMinn near Barrow, AK, 1971-72 | 2: Tanker <i>Raphael</i> spill, Finland, 1969 |
| C: Experimental spill in Balaena Bay, Canada, 1974-75 | 3: Tank farm accident in Deception Bay, Canada, 1970 |
| D: Experiments in Yellowknife, Canada, 1976 | 4: Tanker <i>Arrow</i> spill, Chedabucto Bay, Canada, 1970 |
| E: Experiments by Energetex in Waterloo, Canada, 1977 | 5: Collision of <i>Othello</i> and <i>Katylisia</i> , Tralhavet Bay, Sweden, 1970 |
| F: Experiments at McKinley Bay, Canada, 1979-80 | 6: Diesel spill in ice choked river, Sweden, 1972 |
| G: Experiments by Energetex at Mckinley Bay, Canada, 1979-80 | 7: <i>Imperial St. Claire</i> spill in Lake Huron/Georgian Bay, Canada, 1976 |
| H: Experiments at McKinley Bay, Canada, 1981 | 8: Barge <i>Bouchard #65</i> accident in Buzzards Bay, MA, 1977 |
| I: Experiments at Prudhoe Bay, AK, 1982 | 9: Cargo vessel <i>Edgar Jourdain</i> spill, Hall Beach, Canada, 1980 |
| J: Experiments at McKinley Bay, Canada, 1982 | 10: Storage tank leak, Warwick Lake, Canada, 1983 |
| K: Tier II burn tests at Prudhoe Bay, AK, 1983 | 11: Tank farm release, ME, 1993 |
| L: Experiments at OHMSETT, NJ, 1984-86 | |
| M: Experiments at Cape Bretton, Canada, 1986 | |
| N: Experiments in Calgary, Canada, 1986 | |
| O: Experiments at Svalbard, Norway, 1990-94 | |
| P: Experiments in Barents Sea, 1993 | |
| Q: Experiments at Prudhoe Bay, AK, 2002-03 | |
| R: Experiments at Svalbard, Norway, 2006-08 | |
| S: Experiments in Barents Sea, 2008-09 | |

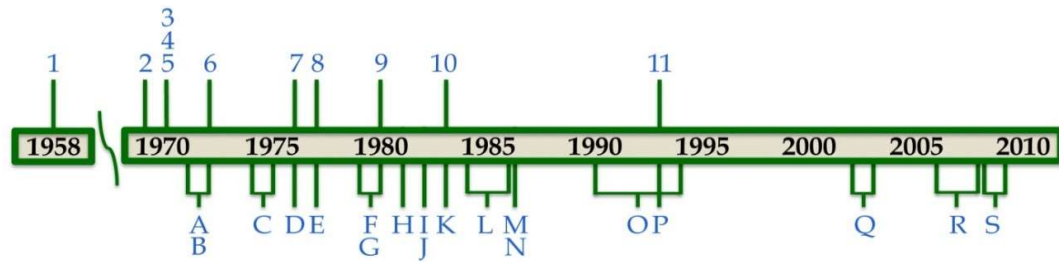

Figure E-2 Timeline of experimental spills and actual incidents involving burns in ice.

R&D on equipment and techniques for in situ burning in ice-affected waters is also presented in this report and covers igniters, fire-resistant booms, floating burners and additives such as ignition and burn promoters, smoke suppressors and herders. The history of each technology is reviewed. At present the following primary equipment is commercially available for in situ burning operations:

- Two kinds of igniters for surface deployment into oil contained in fire booms;
- Two aerial ignition systems, one of which is no longer produced, which were specifically designed for oil in ice;
- Four types of fire boom for use in open water and light drift ice; and
- Two herding agents for thickening oil for ignition and uncontained burning in pack ice.

Environmental and human-health aspects of in situ burning are also covered in the report. In situ burning removes surface oil by driving much of it into the atmosphere in the form of combustion gases and soot. In this way in situ burning reduces the environmental threat posed by the oil slick, but only at the cost of increasing the environmental impact posed by the airborne plume. Whether or not spilled oil is ignited, a weathered residue is left on the surface. The challenge for decision makers is to compare the effects of burning versus not-burning and choose the option that provides the greater net benefit to the environment.

A literature search identified little published evidence of health or environmental effects from burning in either actual spills or in laboratory tests. Case studies of burns in major spills have revealed no significant impacts to human or ecological resources. Spills in which tankers have accidentally caught fire have resulted in little if any impact of the smoke plume or burn residue on the environment and even the most significant burn event ever experienced, the Kuwait oil fires of 1991, does not appear to have caused lasting environmental or human health impacts.

A number of studies have examined the composition and environmental fate of burn emissions. These studies showed that at least some burn emissions (e.g., particulate carbon, sulfur dioxide) may pose a threat to wildlife or human health in the area immediately downwind of a burn, but exposure conditions would fall below threshold levels at most within a few kilometres downwind of the burn. The hazards from smoke can be mitigated by maintaining prescribed separation distances from sensitive downwind areas. Air samples taken during the *Deepwater Horizon* in situ burning operations appear to corroborate this.

Burn residues seem to pose little threat to aquatic resources and human use of water resources. In addition, the volume of residue left after a burn would be much reduced over the parent spill and the toxicity of the residue appears to be similar to that of highly weathered, unburned oil. As a consequence, environmental risks from burning would appear to be minor.

Evaluating potential impacts of leaving the oil unburned and of burning the oil, and comparing the overall effects is the logical approach for making a burn/no-burn decision. Estimates of impact are based on the fate of unburned oil and the products of burning, the distribution of resources, and the sensitivities of those resources to unburned oil and to burning. Hypothetical risk evaluations were conducted to assist in estimating the sensitivity of resources, and characterizing the potential impact on those resources resulting from burning or from unburned oil. In short, these evaluations support the view that in almost all circumstances burning crude oil on water reduces the potential risks to humans and the environment, compared with leaving the same oil unburned.

The report concludes with a review of the issues and criteria for planning and implementing a safe and effective controlled burn of spilled oil in ice-affected waters. These are considered within the context of the following categories:

- Feasibility of burning;
- Resources necessary to carry out a successful burn; and
- Avoiding or minimizing health risks and environmental impacts.

Arctic spill scenarios could potentially include sea conditions ranging from open water, various concentrations of drift and pack ice, and solid or near-solid ice cover. In situ burning has a potential role in each of these situations with tactics selected to suit the specifics of the scenario.

CHAPTER 1. INTRODUCTION

This report comprises a review of in situ burning (ISB) in ice-affected waters commissioned by the International Association of Oil and Gas Producers (OGP). In situ burning means the intentional, controlled burning of oil on water, ice or snow in place (i.e., without picking up or removing the oil first). The report was developed to synthesise best available knowledge about ISB as an option to respond to accidental spills associated with exploration and development drilling, production and transportation of crude oil in Arctic waters.

1.1 Objective

The objective of the project is to prepare materials to inform stakeholders as a means to promote technical consideration and acceptance of ISB in ice-affected waters by industry, regulatory and other external stakeholders. The authors have strived to produce a thorough, in-depth State of Knowledge report on in situ burning in ice-affected waters intended for researchers, specialists and technically inclined stakeholders interested in scientific, technological, environmental and human health details of ISB response in ice conditions. On land or shoreline ignition and burning of spills is beyond the scope of this report.

1.2 Recent Interest in In Situ Burning

In situ burning is a countermeasures technique that has rarely been used on marine oil spills, but its successful use during the recent *Deepwater Horizon* response has increased interest. The deliberate controlled burning of spilled oil with fire booms during the Gulf of Mexico *Deepwater Horizon* (DWH) response eliminated between 220,000 and 310,000 barrels of oil that could have otherwise reached shorelines and other sensitive resources in the Gulf of Mexico. Between April 28th and July 19th, 2010, over 400 burns were initiated and resulted in the removal of between 220,000 and 310,000 bbls of oil (USCG, 2011; Mabile, 2012). Burns continued throughout this period in daily-approved ISB Burn Areas, typically within 3 to 15 miles of the DWH spill source (Allen *et al.*, 2011).

Use of in situ burning is not new: the first deliberate burn of oil spilled on ice occurred in 1958 on the frozen Mackenzie River. Research on in situ burning as an oil removal tool for spills in sea ice began in the 1970s, in support of offshore drilling efforts in the Beaufort Sea.

In general, in situ burning has proved effective for oil spills in ice conditions and has been used successfully to remove oil spills in ice-covered waters resulting from storage tank and ship accidents in Alaska, Canada and Scandinavia since the 1970s. Although there have been numerous incidents of vessel oil spills that inadvertently caught fire, intentional ignition of oil slicks on open water has only been seriously considered since the development of fire booms beginning in the early 1980s.

Added interest in in situ burning of spills on water has also developed as a result of research in the mid-1980s that suggested that large spills on water might be ignited via aurally-deployed igniters and successfully burned without the use of containment boom. The theory is that, if ignited soon enough, thick slicks of burning oil should remain thick enough for burning because of the herding action of the strong air currents drawn into the burning slick zone to feed the fire. This phenomenon was observed repeatedly during burns conducted following the DWH incident in the Gulf of Mexico (Allen *et al.*, 2011).

Building on this concept of uncontained burning, a class of spill-treating agents called herders (or surface collecting agents) has recently been researched, developed and are now available commercially, and can be used to contract and thicken oil slicks in drift ice for ignition and efficient in situ burning without the need for fire booms, even if the slick has spread too thin to ignite.

1.3 Advantages and Operational Issues Associated with In Situ Burning

The decision to employ in situ burning involves trade-offs between the benefits of using burning to remove oil from the water or ice surface and the potential effects of burning. In most cases for spills in ice-covered waters, the benefits far outweigh the potential detrimental effects. The following are some of the key advantages and operational issues that should be considered in the use of in situ burning as an oil spill countermeasures tool. (Details supporting the following statements are presented in subsequent chapters of the report).

1.3.1 *Simple Logistics:*

In situ burning of thick, fresh slicks can be initiated very quickly by igniting the oil with devices as simple as an oil-soaked sorbent pad. In ice conditions, the ice itself often provides natural containment of spilled oil, keeping it thick and slowing weathering processes for extended periods of time, thus allowing oil burning operations to proceed with only helicopters and igniters. The use of towed fire-resistant boom, even in light drift ice, to capture, thicken and isolate a portion of a spill, followed by ignition, is far less complex than the operations involved in recovery, transfer, storage, treatment and disposal. The DWH response involved less than 100 people, 30 vessels (mostly vessels of opportunity), 2 aircraft, 23,000 ft. of fire boom and 1,700 igniters to remove between 220,000 and 310,000 bbls of oil (Mabile, 2012).

1.3.2 *High Elimination Rates:*

The burning rate of thick (1-cm or more), large (3-m diameter or more) slicks of relatively fresh oil has been measured to be in the range of 3 mm/minute. During the DWH response it is estimated that ISB removed almost twice the oil removed by skimming (USCG 2011), including burning 50,000 to 70,000 bbls on one day alone. Each burn removed between 600 and 850 bbls of oil at a rate averaging 700 to 800 bbl/h. One single 12-hour burn removed 6,000 to 8,300 bbls of oil (Mabile, 2012). This unusually high volume of oil burned within a single fire boom was possible because of the low volatility of the encountered oil and the ability to feed oil to an ongoing burn safely and effectively.

1.3.3 *High Efficiency of Burn:*

The volume of oil eliminated depends on the original thickness of oil, which is commonly burned to a thickness ranging from 1 to 10 millimetres depending on the type of oil burning. Burning oil layers of about 100 millimetres or more can thus result in an efficiency of removal of 90 to 99 percent.

1.3.4 *Versatility:*

In situ burning can be used on fresh water or salt water; on lakes, streams, and oceans; onshore; or on wetlands/marshes with only a few centimetres of water. Burning can be used in ice covers from trace to 9+/10ths, in snow, on calm water and in seas approaching a Beaufort scale wind

force of 3 to 4. Burning of spilled oil can be used under tropical and Arctic conditions, and is particularly effective in ice and snow conditions.

Cost: Based on comparable spill events and volume removal rates, the cost of controlled burning is likely to be substantially less than that of physical recovery, and the use of chemical dispersants.

1.3.5 *Flashback and Secondary Fires:*

If oil on water is at a temperature near or above its flash point, ignition of the oil will result in very rapid spreading of the flame. In cases where a large amount of volatile oil is spilled, a cloud of vapours can collect near the source in calm wind conditions and may represent a significant flash-back and/or explosion hazard. In such cases, care must be taken to isolate the portion of the slick to be burned from the source of spillage and from other areas of the slick. Careful planning and training with in situ burning techniques can eliminate risks of secondary fires. The successful and safe use of in situ burning at the recent DWH incident has gone a long way to allay fears involving the controlled burning of oil on open water.

1.3.6 *Combustion By-products:*

In situ burning of oil slicks on water can be described as "starved combustion" in which not enough air (oxygen) is drawn into the fire to burn the fuel completely to carbon dioxide and water vapour. As a result, in situ burning produces a dense, black plume of smoke rising from the fire. The plume is slowly dispersed by wind and is usually visible only within a few kilometres of the burn site. Laboratory and field tests have indicated that the soot produced is about 2-20% of the mass of oil burned. Possible impacts of the soot on responders are managed by keeping upwind or crosswind of the burn. Any risk to human habitations are negated by maintaining prescribed separation distances (exclusion zones) upwind of any onshore populated areas.

1.3.7 *Burn residue*

Burn residue is the material that remains on the water surface after an in situ burn naturally extinguishes. Burn residue is generally depleted of lighter petroleum constituents, which usually reduces its toxicity, and it contains elevated concentrations of heavier compounds. In almost every case, even if the residue is not recovered, a Net Environmental Benefit Analysis (NEBA) will show that the potential harm to the environment from the residue is far less than the potential harm from the oil if it is not burned.

1.4 [Summary of Key Issues](#)

Proponents of burning believe that the method shows great promise as a primary response technique and that the environmental trade-offs (burning vs. not burning oil spills) strongly favour burning in many spill scenarios in ice-affected waters. They further believe that the most important issues relate to operational feasibility. Several large field experiments have demonstrated the high effectiveness of in situ burning in fast and very close pack ice. Further, well-designed field trials are necessary to answer questions about in situ burning in drift ice.

Opponents of in situ burning often fail to view the issue in terms of environmental trade-offs. They rather cite specific reasons for proceeding cautiously before accepting and approving the method. These include:

1. A perception of inadequate research and demonstration efforts on the feasibility of successful ignition and combustion of oils (especially weathered and emulsified oils) in open waters and in diverse climates;
2. A fear of the potential hazards of fire and combustion products to human life, property and natural resources;
3. A lack of adequate information on the environmental and human health implications of the smoke and residue generated by in situ burning; and,
4. A general lack of logistical and systems planning for the use of burning in spill contingency plans.

This study serves to summarise and evaluate the state of knowledge in the first three of these areas and allows both proponents and opponents of in situ oil spill burning to work with the facts as we know them today and make decisions that are based on science, and not just opinions.

1.5 Report Outline

This report documents and evaluates important information on the subject of oil spill in situ burning in ice-affected waters. It is organized in such a way as to allow researchers, specialists and knowledgeable stakeholders to access the science and technology of in situ burning in a logical and sequential manner.

- **Chapter 2** follows with a brief chronological review of in situ burning at both accidental and experimental spills. This is to provide some historical context to the studies and technologies that are reviewed in the following chapters.
- Without a good understanding of how oil spills in ice-affected waters behave and what their fate is, it is not possible to fully grasp the capabilities and limitations of in situ burning in this complex environment. **Chapter 3** describes the fate and behaviour of oil spills in various sea ice conditions in detail with particular reference to factors that affect the ignition and burning of slicks on water and ice.
- **Chapter 4** presents a treatise on the science of in situ oil burning, including a detailed literature review of all relevant scientific studies and experiments on the subject. Excluded are studies related to environmental and human-health issues, which are reserved for **Chapters 7** and **8**. All key physical and chemical processes involved in in situ burning are discussed as well as the factors that control ignitability and combustibility of oil spills on water. Also discussed in detail is how various oil spill processes, such as water-in-oil emulsification, affect the ignition and burning processes.
- **Chapter 5** comprises an in-depth review of literature on in situ burning of oil spilled in a wide range of ice conditions (from landfast ice to trace drift ice) with a particular focus on mesoscale test tank and field experiments. The subject of burning oil spills in snow on ice is also addressed. Burning on land (tundra) and shorelines is not addressed in this report: the focus is burning offshore.
- **Chapter 6** deals with technologies available for in situ burning in ice-affected waters including: igniters, fire-resistant booms, floating burners and additives such as ignition and

burn promoters, smoke suppressors and herders. **Chapter 6** presents a brief history, along with detailed descriptions and tabular data on existing or recommended burn systems, while addressing those that, for one reason or another, are no longer available or recommended. Obsolete systems are included not only for completeness, but also to help future researchers avoid "re-inventing the wheel" while attempting to develop different or improved systems.

- **Chapter 7** consists of a review of the effects of untreated oil in various ice conditions. The purpose of the chapter is to provide baseline information on the environmental and human-health effects of untreated oil spills in ice against which the effects of burning can be compared.
- **Chapters 8 and 9** discuss and evaluate the important subject of the environmental and human-health effects associated with in situ burning in ice conditions. **Chapter 8** begins with a literature review. The review is necessarily short because there have been few studies that attempt to measure directly the ecological or human health effects from in situ oil burns. However, several experiments with small amounts of oil have determined the chemical composition and environmental fate of burn products. The results of these studies are provided in **Chapter 8**. The available published results of smoke sampling programmes during the DWH in situ burning effort are also summarized.
- The results of these experiments figure prominently in **Chapter 9** where a detailed risk evaluation is conducted of the acceptability of in situ burning. The evaluation first describes the chief pathways by which humans could be exposed to the chemicals produced during in situ burning of an oil spill and identifies the "chemicals of concern" and their exposure thresholds or dosages for adverse health effects. The risk evaluation then examines and compares the carcinogenic and non-carcinogenic risks associated with exposures to those chemicals. A similar analysis is conducted with respect to ecological risks. The chapter concludes with a discussion of the "acceptability" of in situ burning.
- **Chapter 10** is a summary of operational aspects of mounting an in situ burning operation in ice-affected waters.

1.6 Scope of Study

The scope of the study is large in that it attempts to document and evaluate virtually all knowledge and experience on the subject of in situ burning of oil spills in ice-affected waters. There are several areas of in situ burning that this study does not deal with:

- The subject of the report is in situ burning of oil spills, that is, burning of marine oil spills "in place" while they are on the water surface or ice. The problem of burning oil on a stricken vessel or the use of combustion or incineration techniques to deal with recovered oil or materials collected in a shoreline cleanup operation is not dealt with.
- In situ burning of oil on land or tundra, shorelines or marshes is not covered.
- Safety of spill workers and safety regulations has not been specifically addressed in this document. These are being addressed in a parallel study under the auspices of API.

References to Chapter 1

- Allen, A.A., N.J. Mabile, D. Costanzo, and A. Jaeger. 2011. **The Use of Controlled Burning during the Gulf of Mexico Deepwater Horizon MC-252 Oil Spill Response**. In: *Proceedings of the 2011 International Oil Spill Conference*, Portland, OR, API, Washington, DC, U.S.
- Mabile, N. 2012. **Controlled in-Situ Burning: Transition from Alternative Technology to Conventional Spill Response Option**. In: *Proceedings of the Thirty-fifth Technical Seminar on Environmental Contamination and Response*. Environment Canada, Ottawa, ON, Canada.
- United States Coast Guard (USCG). 2011. **BP Deepwater Horizon Oil Spill: Incident Specific Preparedness Review (ISPR)**, USCG, Washington, DC, U.S.

CHAPTER 2. HISTORY OF IN SITU BURNING AT EXPERIMENTAL AND ACCIDENTAL SPILLS

2.1 Introduction

This chapter presents a chronology of the use of in situ burning techniques at experimental and accidental spills. The purpose is to provide some historical context to the technological developments that have been made over the past 50 years or more. Although an ad-hoc approach was used in the past on actual spills, various promising results were achieved despite the lack of planning, and these results encouraged the R&D activity that led to the in situ burning technologies that exist today.

The following historical review is intentionally brief; more detailed information on the various substances, equipment and techniques that have been used at both experimental and actual spills is presented in **Chapter 6**. The review begins with a table that lists all relevant spills in chronological order, followed by a brief history of only accidental spills where oil was burned on water or ice – incidents where spills were burned on land or in marshes have been excluded. The experimental spills in the table are discussed in detail in **Chapters 4, 5 or 6**.

2.2 Spills Involving In Situ Burning

Table 2-1 lists the 60 or so spills (both accidental and experimental) that have provided the base of the present knowledge of oil spill in situ burning in ice-affected waters. Most detailed information has been derived from laboratory tests and the mesoscale tests noted in the table. Of the actual spills listed, eighteen included the purposeful burning of oil on water, as opposed to oil accidentally burning. Many of the listings in **Table 2-1** involve oil in ice conditions.

2.3 Chronological History of Burning at Accidental Spills

The first recorded use of in situ burning as a spill countermeasures technique involved the removal of oil spilled from a pipeline on ice in the Mackenzie River at Norman Wells, N.W.T. in 1958. Oil was boomed with logs and successfully burned off (McLeod & McLeod, 1972).

The next recorded use of in situ burning was in response to the *Torrey Canyon* grounding in March 1967 off Lands End, U.K. The vessel's entire cargo of 100,000 tons of Kuwait crude was lost (Wardley-Smith, 1971). After salvage operations failed, attempts were made to burn the oil in the vessel, on the sea and on beaches. Aerial bombardment was used to ignite and burn oil in the tanker and on the sea. Swift *et al.* (1968) report that over a three-day operation some 73,000-kg of high explosives, 45,000-L (283-bbl) of aviation kerosene and 14,000-L (90 bbl) of napalm were dropped on the ship to set the cargo afire. Estimates (Swift *et al.*, 1968) place the amounts of oil burned in the ship as high as 40,600 to 50,800-tonnes.

Four attempts were made to ignite seemingly thick oil slicks on the sea near the *Torrey Canyon* using pyrotechnic devices containing sodium chlorate (Swift *et al.*, 1968; Anonymous, 1967) but these attempts were unsuccessful. It was concluded that, after the Kuwait crude had been on the water surface for only 40-minutes, wave action had emulsified it to such an extent that it would not ignite (Anonymous, 1967).

Table 2-1: Summary of In Situ Burning: Tests and Use on Spills on Water and in Ice Conditions

Date	Type/Location	Description	Type	Results
1958	Pipeline spill in Mackenzie River, Canada	Spill was boomed with logs and burned.	Crude	Burn was successful
1967	Tanker accident (Torrey Canyon), USA	Attempts were made to burn oil on water with bombs, napalm and other materials.	100,000-tonnes of crude	40,000 to 50,000-tonnes of oil burned on ship.
1969	Holland	Series of experiments. Igniter Kontax tested.	Crude	Proved the possibility of burning slicks.
1969	Cargo ship Eiva sank releasing oil in Gulf of Finland	Oil burned on shores and bays using paraffinic oil as primer.	15-tonnes of diesel fuel	Burn was reported to be successful.
1969	Tanker Raphael went aground off Finland	Peat moss, fuel oil and petrol used.	60-tonnes of crude	90% of oil was burned.
1970	Accident in Chedabucto Bay, Nova Scotia (Arrow), CAN	Some isolated slicks were burned using Seabeads. Varsol also used as primer. Oil on shoreline was ignited and burned with napalm and a flame thrower.	Bunker C, approx. 16,000-tonnes	Mixed results.
1970	Vessel collision in Tralhavet Bay, Sweden, (Othello and Katelysia)	Spill was trapped in pack ice and a silica wicking agent (Cab-O-Sil ST-2-0) was used to burn. Conditions precluded mechanical containment and recovery.	Between 52,000 and 90,000-tonnes of Bunker C spilled	Good results reported.
1970	Accident in Deception Bay, Quebec, CAN	Tank farm accident caused by slush avalanche. Onshore spill reached intertidal ice.	1500-tonnes of diesel and gasoline spilled	Oil pumped to ice surface and burned; some oil on ice, and contained by near shore ice also burned.
1972	Diesel fuel spill in ice-choked river in Sweden	Sorbent product Saneringsull used as wicking agent.	600-tonnes of diesel fuel oil	400-tonnes burned.
1973	Canada	Rimouski experiment	Crude	Demonstrated high removal rates possible, >75%.
1974 - 1975	Experimental spill, Balaena Bay, Canadian Beaufort Sea	Oil spilled under ice was burned in spring as it accumulated in melt pools on the ice surface.	45-tonnes of crude	Highly successful burns; proved the effective use of burning oil in ice.
1976	Tanker Urquiola went aground off Spain	Oil burned accidentally over three-day period.	100,000-tonnes of light Arabian crude	
1976	Accident in Lake Huron (Imperial St. Clair), USA	Oil became incorporated in ice, and numerous burns conducted as oil melted out of ice. Oily rags used as igniters.	Diesel and gasoline, 220-tonnes spilled	80-95% of the oil burned.
1976	Tanker Argo Merchant went aground off Nantucket, USA	Tullanox 500, primed with JP-4, used as igniter.	28,000-tonnes of No. 6 Fuel	Not able to burn slicks on open water.
1976	Experiments in Canadian Arctic	Various tests on parameters controlled burning.	Crudes	
1977	Barge (Bouchard #65) accident in Buzzards Bay, Massachusetts, USA	A pool of 950 liters (6 bbl) in broken ice was ignited with Tullanox/JP-4 igniters dropped from helicopter	No.2 fuel oil, 300-tonnes spilled	15-tonnes burned.

Table 2-1: Summary of In Situ Burning: Tests and Use on Spills on Water and in Ice Conditions

Date	Type/Location	Description	Type	Results
1979	Tank collision (Atlantic Empr68 and Aegean Captain) in Caribbean Sea	Two fully laden VLCC's collided leading to oil burning on water.	288,000-tonnes of crude	Virtually all oil burned.
1979	Accidental burn of grounded Burmah Agate, Galveston, Texas, USA	Oil burned on the tanker and on water.	Nigerian crude and blend, 40,000-tonnes	74% of oil burned.
1979 - 1980	Experimental release	Oil release with air under first-year sea ice to simulate blowout under ice.	Prudhoe Bay crude, 20-m ³	
1980	Tests at Port Mellon, B.C., CAN	Static test of Dome Petroleum's stainless steel fire-resistant boom with burning crude oil.	Redwater crude oil, 1.5-m ³	
1980	Cargo vessel Edgar Jourdain went aground in NWT, CAN in ice conditions in September	Oil burned after ice melted.	50-tonnes of marine diesel fuel	Successful burn.
1981	Tests at EPA OHMSETT test tank, USA	Test of Dome Petroleum's boom with burning crude oil and waves in test tank (22 tests)	Circa 4X light oil and Murban crude	
1981	Canada	McKinley Bay experiment	Crudes	Noted difficulty In burning emulsions.
1983	Storage tank leak into Warwick Lake, Ontario, CAN in January	Oil pumped to ice surface and burned over winter and following spring.	59-tonnes of diesel fuel oil	85% burned.
1983	Tanker Honam Jade goes aground off South Korea	Uncontained 3-km diameter slick set afire; oil burned for 2-hours; residue sunk.	2000-tonnes of Arabian Heavy crude oil	Successful intentional burn of large, uncontained spill.
1983	Tier 2 burn test in Prudhoe Bay test pit (Task 1)	Four tests conducted with uncontained oil spilled in broken ice conditions.	Circa 4X light oil and Murban crude	55%-73% of oil burned.
1983	Tier 2 burn tests in Prudhoe Bay test pit (Task 2)	Burning of oil inside fire-resistant boom in test pit (single burn and continuous burn); follow-up tests conducted in test tank.	Single burn: 130-L (0.8 bbl) fresh, degassed Prudhoe Bay crude. Continuous burn:	72%-88% of oil burned.
1984	Experiments at OHMSETT (New Jersey, USA)	4 tests were run in EPA test tank.	Prudhoe Bay crude (fresh and weathered)	
1984	Canada	Series of experiments	Several	Uncontained burning only possible in few conditions.
1985 - 1989	Various small-scale tests, USA	National Institute of Standards and Technology tests to study combustion and smoke generation.	Alberta Sweet, Murban, Prudhoe Bay	Comprehensive analysis of physics and fate of burn products.
1986	Canada	Ottawa experiment/analysis	various	Analysis shows PAH's about same in oil and residue.
1986	Experiments at OHMSETT (New Jersey, USA)	Test in EPA test tank	Prudhoe Bay and Hibernia crudes	
1986	Experimental spills off Nova Scotia, CAN	Two spills each 1 m ³ ignited after several hours spreading in pack ice.	Alberta crude	

Table 2-1: Summary of In Situ Burning: Tests and Use on Spills on Water and in Ice Conditions

Date	Type/Location	Description	Type	Results
1986	ACS Deadhorse Helitorch tests	Tests of ignition of crude oil in test pans using a Helitorch	Fresh and weathered crude oil (20 L/pan)	Tests confirmed the ability to ignite oil with a Helitorch
1986	Calgary, Alberta, CAN	25 tests in Jan. and Feb. at the Esso Research Ice Basin to test burning in ice leads (2 experiments in brash ice)	Aged Normal Wells crude	
1988	Experimental spill off Spitsbergen	100-m of 3M Fire Boom used to contain slick, which was ignited with Helitorch	Statfjord crude, 2 m3	Successful burn in a towed U-boom configuration. 95% burn efficiency.
1988	St. Vincent's Bay, B.C., CAN spill	Burning of spilled diesel on water; winter.	9-tonnes diesel spilled	
1989	Test burn in Prince William Sound, AK, USA during Exxon Valdez spill	150-m of 3M Fire Boom towed by 2 vessels to collect oil and contain it for burning; the oil had been floating on calm water for 30 to 40 hours before it was burned.	Prudhoe Bay crude, approx. 60 to 120-tonnes.	98% burn efficiency in fire boom collected oil. Residue of stiff, taffy-like oil.
1990	Rivers Inlet, B.C., CAN	Fuel burned on water	Approx. 85-tonnes fuel	Efficient removal; noted need for experienced personnel.
1990	ACS test burns	Purpose was to test 3M Fire Boom for a 48-hour burn in a test tank.	Prudhoe Bay crude	
1990	Tanker accident (Mega Borg), Gulf of Mexico, USA	Fire from series of onboard explosions 00 tanker	Palanc Angola crude, 15,000-tonnes	Estimated 51 % burned and about 27% evaporated.
1990	Tanker accident (Haven), Gulf of Geneva, Italy	Fire from series of onboard explosions within 500-m of populated area.	Iranian heavy crude, 144,000-tonnes	three-day fire consumed most oil.
1991	Tanker accident (Aegean Sea), La Coruna, Spain	Fire from onboard explosions within 500-m of populated area.	Brent crude	24 hours burn - smoke led authorities to evacuate approximately 100 houses near harbour.
1991	Oil well blowout off Louisiana, USA	Oil contained by conventional boom was Ignited and burned; boom was destroyed.		
1991 - 2000	Test burns in Mobile, Alabama, USA	Mesoscale tests in water-filled test tank with crude and diesel slicks up to 15m in diameter inside fire-resistant boom. NIST	Louisiana crude	Comprehensive analysis of physics and chemistry of burning and fire boom performance
1991 - 1994	Field experiments on Svalbard, Norway	Mid-scale tests of burning crudes and emulsions on ice and in simulated pack ice contained and uncontained	Statfjord crude	Advanced knowledge of emulsion burning, developed enhanced igniters for emulsions

Table 2-1: Summary of In Situ Burning: Tests and Use on Spills on Water and in Ice Conditions

Date	Type/Location	Description	Type	Results
1993	Test burns off Newfoundland, CAN	Two burns of boomed oil, 29 m3 and 48 m3.	Alberta Sweet Mix Blend crude oil	Detailed results on the fate and chemistry of the products of combustion.
1993	Maine (USA) tank farm release into ice and snow-covered pond and wetland	Oil unreachable by vacuum trucks was burned	JP-5	98% of remaining oil removed by burning
1994	Test tank experiments in Alaska, USA	Mid-scale experiments on burning emulsions and collecting soot plume data	Alaska North Slope crude	Successful burns with emulsion breakers in fire boom on test pond
1996	Offshore burn test with fire boom in UK	Full-scale test of emulsion-breaking igniter on 25% water emulsion in fire boom	Larkwhistle Farm crude	EB igniter successfully lit emulsion in fire boom
1998 - 2002	Fire boom testing at OHMSETT (New Jersey, USA)	Full scale testing of fire booms using ASTM methods employing a propane system	Propane fire simulator	Six fire booms and blankets tested
1999	New Carissa aground off Oregon coast, USA	On board ignition of spilled bunker fuel	Four different bunkers	Oil burned in hulk
2006 - 2008	Experimental burns of oil on ice at Svalbard, Norway	Oil released in ice sheet in spring ignited and burned	Statfjord crude	96% removal efficiency
2008	Experimental burns of oil in pack ice in Barents Sea, Norway	Field tests of herders in drift ice	Heidrun crude	90+% removal of herded slick
2009	Experimental burns of oil in pack ice in Barents Sea, Norway	Field tests of fire booms in drift ice (trace and 3 to 5 tenths) and burning in 7-9/10ths close pack ice	Troll B crude	90% removal of contained slicks
2010	Deepwater Horizon, Gulf of Mexico, USA	Use of controlled burning with fire booms in response to deep water blowout	MC-252 crude	411 oil collection and ignition attempts resulted in 376 burns that removed between 220,000 and 310,000 bbls of oil

Similarly, oil on the shores from the *Torrey Canyon* proved very difficult to ignite and burn. Some success was reported in burning unemulsified oil in pools between rocks (Swift *et al.* 1968). Flame throwers or flame-thrower fuel were used to ignite these pools and they burned nearly to completion. Emulsified oil could be burned on the beach, but only as long as the flamethrower was applied and remained in place. Water boiling out of the emulsion was observed during these tests. Combustion promoters such as "oxygen tiles", wood chips, and magnesium powder, were applied to the emulsified oil, but without success (Swift *et al.*, 1968).

In December 1969, the cargo ship *Eiva* sank releasing 15,000-L (95 bbl) of diesel fuel in the Gulf of Finland. Some of this oil was successfully burned on nearby shores and in bays using paraffin oil as an igniter (Haaktela, 1970). Six-days later the tanker *Raphael* went aground west of Emasoaloo, Finland releasing more than 61-tonnes of crude. Peat moss, fuel oil and petrol were used to remove more than 90% of the oil by burning (Coupal, 1972; Haaktela, 1970).

On February 4, 1970, the *Arrow* ran aground in Chedabucto Bay, Nova Scotia, and spilled most of its 16,300-tonnes cargo of Bunker C. SeaBeads was used successfully on isolated larger slicks

(4.6-m diameter) and on some beaches to burn the oil. The slicks were primed with Varsol and ignited with a marking flare. Once ignited, the slicks tended to spread and had to be reignited several times to achieve a 50% reduction (Freiberger & Byers, 1971; Battelle, 1979). Part of the spill was burned by spilling two drums of fresh oil on it and igniting it with Kontax (Coupal 1972). Oil deposited onshore at Arichat, Nova Scotia was ignited with napalm and a flame thrower and reportedly burned well (Coupal, 1972).

In March, 1970, the *Othello* collided with the *Katylisia* in Tralhavet Bay near Stockholm, Sweden and spilled about 95,000-L (600 bbl) of heavy fuel oil in broken ice. Early efforts by the Swedish Coast Guard to promote ignition of the oil with kerosene failed. Cab-O-Sil was applied by hand from small tugs to 0.3 to 0.6-m diameter pools of oil contained by ice and ignited with small amounts of primer. It is reported that this successfully removed the oil (Anonymous, 1970; Freiberger & Byers, 1971; Energetex, 1979).

In June, 1970, a slush avalanche near Deception Bay, Quebec caused 1,940,000-L (12,200 bbl) of diesel fuel and gasoline to spill from a shore side tank farm onto and under the adjacent sea ice. Exposed pools of oil were ignited and burned using oily rags as igniters; oil trapped beneath the ice was pumped onto the surface and was subsequently burned (Ramsier *et al.*, 1973).

In January, 1972, 610-tonnes of diesel fuel was accidentally discharged into the icy Ume River in Sweden. The oil spread downriver into a small lake. A particulate sorbent product "Saneringsull" was used as a wicking agent and about 406-tonnes of oil was burned over a period of a month from a mixture of oil, ice and snow on the lake (Jerbo, 1973).

On the morning of May 12, 1976, the super tanker *Urquiola* went aground in the harbour at La Coruna, Spain, exploded and caught fire. Although not a case of intentional burning, this incident illustrates the high removal rates and efficiencies possible with in situ burning. Approximately 70% of the 100,000 ton spill of light Arabian crude was consumed in the fire over a three-day period (Robertson *et al.*, 1976; Gundlach *et al.*, 1978).

On December 23, 1976, the oil product tanker *Imperial St. Clair* went aground near Parry Sound, Ontario, and spilled 260,000-L (1635 bbl) of gasoline and diesel. Throughout the following winter, as oil appeared on the ice surface it was periodically burned with oily rags. About 80 to 95% of the oil spilled was burned or evaporated. It was noted that it was difficult to burn the oil in very cold and windy conditions (Beckett, 1979).

On December 27, 1976, the *Argo Merchant* went aground near Nantucket Island and spilled most of its cargo of 28,000 tons of No.6 fuel oil. Part of the response by the U.S. Coast Guard involved attempts to burn the oil. One 30-m x 40-m x 15-cm thick slick was treated with Tullanox 500 (a wicking/insulating agent), primed with 200-L (1.25 bbl) of IP-4 and ignited with JP-4-soaked cotton sheets set afire with a flare. About 95% of the Tullanox was blown off the treated slick by wind and the flames would not spread from the sheet to the primed slick. In another experiment boxes of Tullanox 500 charged with JP-4 fuel were dropped onto a slick from a helicopter and ignited with timed thermite grenades. The isolated boxes burned but the flames did not spread (Det norske Veritas, 1979; Battelle, 1979).

On January 28, 1977, 300,000-L (1900 bbl) of No. 2 fuel oil was spilled into ice-covered Buzzards Bay, Massachusetts by the barge *Bouchard #65*. Boxes of Tullanox soaked with jet fuel were dropped from helicopters onto pools of oil in the broken ice. Delay-fused thermite grenades were used to ignite the boxes. The ensuing fires burned for 1 to 2-hours and consumed 4000 to

8000-L (25 to 50 bbl) of oil. 38 to 46 km/h (20 to 25-knot) winds drove the flames from pool to pool in areas where adjacent pools were nearby; in other areas the fires did not spread. Another series of burns was conducted at a later date. These burns were initiated by knotted rags soaked in diesel fuel. Some of these fires had flames 9 to 12-m high and lasted 40 to 50-minutes. Other pools were considered for burning, but were rejected due to concerns about nuisance effects of smoke to nearby residents and the possibility of the fire jumping ashore to beachfront properties. Overall, 15,000-L (95 bbl) of oil was estimated to have been burned (Schrier & Ediam, 1979; Ruby *et al.*, 1978).

Beginning in the late 1970s, a concerted research effort was made to develop in situ burning as a tool for oil spill response in Arctic waters. As these ice-related studies were being conducted, three events in 1979 catalyzed world-wide interest in burning as a method for dealing with oil spills on water: the IXTOC-I blowout in the Bay of Campeche, Mexico, the *Burmah Agate* spill in the U.S. Gulf of Mexico and the sinking of the *Atlantic Empress* off Trinidad. These spills illustrated again the potential for in situ burning to remove large amounts of oil from the sea surface (e.g., for the *Burmah Agate* spill 29,571,600-L (186,000 bbl) or 74% of the spilled oil was burned) and highlighted the need for fire resistant booms to contain burning oil (Kana *et al.*, 1981). The *Atlantic Empress* incident, in which all the oil released from the 288,000 dwt tanker was consumed in fire, was a particularly dramatic illustration of the potential for in situ burning to remove oil from the sea surface (Horn & Neal, 1981).

These spills promoted a serious research effort into fire-resistant containment booms, a major review and experimental programme in the U.S. on in situ burning for open-water spills, and a major effort to quantify the environmental consequences of in situ burning.

In September, 1980, the cargo vessel *Edgar Jourdain* went aground off Hall Beach, N.W.T., and spilled 50,000-L (315 bbl) of marine diesel fuel. Within a week the ice began to grow and froze the remaining oil into the ship. The following spring the remaining fuel was deliberately burned in the ship (Brander-Smith *et al.*, 1990).

In January, 1983, about 59,000-L (371 bbl) of diesel fuel leaked from a storage tank into Warwick Lake, Ontario. Over the ensuing winter and spring about 50,000-L (315 bbl) of this was burned from snow, on ice and after being pumped from beneath ice (Burns, 1988).

On February 28, 1983, the tanker *Honan Jade* went aground off Yosu, South Korea, losing 2,000-tonnes of Arabian Heavy crude oil (Moller, 1992). Some three hours after the spill, one of the cleanup contractors set fire to the main slick, which was circular in shape with a diameter of 3-kilometres. The fire burned with great intensity for about two hours before going out spontaneously and leaving a residue which sank nearby. The sunken oil affected the cultivation of crabs which were being reared in submerged cages (Moller, 1992). Some attempts were made to recover the oil using trawls, but not with much success.

In March, 1989, the *Exxon Valdez* went aground on Bligh Reef in Prince William Sound, Alaska and released 41,000,000-L (257,880 bbl) of crude oil. During the evening of the second day following the accident an estimated 57,000 to 144,000-L (371 to 905 bbl) of slightly emulsified (20 to 30% water) North Slope crude was burned in situ using 136-m of 3M Fire boom (Allen, 1991). This was the first recorded incident of the use of fire-resistant boom at a major spill response. By the time additional burns were attempted, a storm had further emulsified the slick and rendered it unignitable (Exxon, 1990).

In the Gulf of Mexico on June 8, 1990, the *Mega Borg* suffered an explosion during lightering operations and caught fire. By June 16 the fire had been extinguished and the oil leakage stopped. Surveys indicated that 15,000,000-L (94,350 bbl) of oil had been lost; most of which burned near the tanker (OSIR, 3 January 1991), some of which formed large slicks and some 2,200,000-L (13,840 bbl) of which was recovered by skimmers (Leveille, 1991). The remaining cargo (144,000,000-L [905,730 bbl]) was successfully lightered.

In November, 1990, a landslide at Rivers Inlet, B.C. resulted in a spill of some 85,000-L (535 bbl) of fuels from a storage area into the adjacent water. Containment was partially effected by a log boom and boom sticks. Tidal currents were causing continued losses from the contained oil. In order to remove the oil from the aquatic environment, the boom was moved to provide separation between the tank farm, and the collected fuel and the contained slick was ignited using fuel soaked sorbent pads manually placed from small boats. The ensuing burn lasted some 30-minutes and was less than 23-m in diameter. It was estimated that no more than 10,000-L of fuel was burned (Robertson, 1991).

In April, 1991, the tanker *Haven* caught fire and ultimately exploded and broke in three off the coast of Genoa, Italy. At the time it was carrying some 144,000 tons of heavy Iranian crude. The fire lasted three days and consumed most of the oil; this substantially reduced the oil spillage. This fire was intentionally allowed to burn to reduce pollution. Reports suggest an undefined amount of the oil/burn residue sank and covered areas of the sea floor and wreck with solid masses. Some viscous residue remained floating after the spill and caused severe problems for skimmers; thus the main response efforts became those of beach protection and shoreline cleanup (Jacobsson, 1993; Turbini et al., 1993).

On the 29th of September, 1991 an oil well in a bay on the southern coast of Louisiana blew out and subsequently caught fire on October 1. At the time of the fire, conventional boom had been deployed; the contained oil was ignited by the burning well and burned, as did the boom. It was reported that fire-resistant boom was subsequently deployed around the burning well, but was damaged by storm waves (OSIR, 8 October 1992). The well was intentionally allowed to continue burning during well-capping.

During the winter of 1993, a large spill of JP-5 occurred into a pond on the Brunswick Naval Air Station in Maine. About 2/3rds of the oil was recovered by vacuum trucks over one week. The rest of the oil was not accessible, and was burned eight days after the spill. About 98% of the oil burned (Michel et al., 2005).

In 1999 the *New Carissa* went aground on the coast of Oregon. In order to prevent damage to the surrounding area and resources, a decision was made to burn the fuel aboard the ship. A Helitorch was used after opening portions of the cargo space and exposing onboard fuel oil.

The deliberate controlled burning of spilled oil with fire booms during the Gulf of Mexico *Deepwater Horizon* response eliminated between 35,000,000 to 49,300,000-L (220,000 and 310,000 bbl) of oil that could have otherwise reached the shorelines and other sensitive resources in the Gulf of Mexico. Between April 28th and July 19th, 2010, over 400 burns were initiated and resulted in the removal of between 35,000,000 to 49,300,000-L (220,000 and 310,000 bbl) of oil (USCG, 2011; Mabile, 2012).. Burns continued throughout this period in daily-approved ISB Burn Areas, typically within 3 to 15-miles of the DWH spill source. (Allen et al., 2011).

References to Chapter 2

- Allen, A.A. 1991. **Controlled Burning of Crude Oil On Water Following the Grounding of the Exxon Valdez**. In: *Proceedings of the 1991 Oil Spill Conference*, March 4-7, San Diego, CA. American Petroleum Institute, Washington, DC, U.S., pp. 213-216.
- Allen, A.A., N. Mabile, D. Costanzo, A. Jaeger. 2011. **The Use of Controlled Burning during the Gulf of Mexico Deepwater Horizon MC-252 Oil Spill Response**. In: *Proceedings of International Oil Spill Conference*, 2011, May 23-26, Portland, OR. API. Washington, DC, U.S.
- Anonymous. 1967. **Chemicals vs. Crude Oil**. *Chemical Week*, 100(20):49.
- Anonymous. 1970. **Oil for Burning**. *Marine Pollution Bulletin*, 1(12):181.
- Battelle. 1979. **Combustion: An Oil Spill Mitigation Tool**. Report for U.S. Department of Energy, Contract No. EY-76-C-06-1830. U.S. Department of Energy, Washington, DC, U.S.
- Beckett, C.J. 1979. **The Grounding of the Imperial St. Clair -a Case History of Contending with Oil in Ice**. In: *Proceedings of the 1979 Oil Spill Conference*, March 19-22, New Orleans, LA. American Petroleum Institute, Washington, DC, U.S., pp. 371-375.
- Brander-Smith, D., D.P. Therrien, and J. Tobin. 1990. **Protecting our waters**. Public Review Panel on Tanker Safety and Marine Spills Response Capability. Final Report, September 1990. Minister of Supply and Services Canada 1990. Catalogue No. EN21-91/1990 E.
- Burns, R.C. 1988. **Cleanup and Containment of a Diesel Fuel Spill to a Sensitive Water Body at a Remote Site under Extreme Winter Conditions**. In: *Proceedings of the Eleventh Arctic and Marine Oilspill Program Technical Seminar*, June 7-9, Vancouver, BC. Environment Canada, Ottawa, ON, Canada, pp. 209-220.
- Coupal, B. 1972. **Use of Peat Moss in Controlled Combustion Technique**. Environment Canada Report No. EPS 4-EE-72-1, 32 p. Environment Canada, Ottawa, ON, Canada.
- Det norske Veritas. 1979. **Tanker oil spill analysis study**. Technical Report for Canadian Marine Drilling Limited. Det norske Veritas Ship Division.
- Energetex Engineering. 1979. **A Review of Oil Slick Combustion Promoters**. Environment Canada Report EPS-3-EC-79-8. 48 p. Environment Canada, Ottawa, ON, Canada.
- Exxon. 1990. **Valdez Oil Spill Technology**. Exxon Production Research Company.
- Freiberger, A. & J.M. Byers. 1971. **Burning Agents for Oil Spill Cleanup**. In: *Proceedings of the 1971 Conference on Prevention and Control of Oil Spills*, June 15-17, Washington, DC. American Petroleum Institute, Washington, DC, U.S. pp.245-251.
- Gundlach, E.R. & M.O. Hayes. 1971. **Vulnerability of Coastal Environments to Oil Spill Impacts**. *Mar. Tech. Soc. J.* 12 18-27.
- Gundlach, E., C. Ruby, M. Hayes, and A. Blount. 1978. **The Urquiola Oil Spill, La Coruna, Spain: Impacts and Reaction on Beaches and Rocky Coasts**. *Environmental Geology*, 2(3):131-143.
- Haaktela, I. 1970. **Oil Spills off Finland**. *Marine Pollution Bulletin* 1(1):19-20.
- Horn, S.A. & P. Neal. 1981. **The Atlantic Empress Sinking -a Large Spill Without Environmental Disaster**. In: *Proceedings of the 1981 Oil Spill Conference*, March 2-5, Atlanta, GA. American Petroleum Institute, Washington, DC, U.S., pp. 429-435.
- Jacobsson, M. 1993. **The Rio Orinoco and the Haven -Two Major Cases from a Legal Point of View**. In: *Proceedings of the 1993 Oil Spill Conference*, March 29-April 1, Tampa, FL. American Petroleum Institute, Washington, DC, U.S., pp. 663-666.
- Jerbo, A. 1973. **Two types of oil spills in Swedish inland waters -Tests of new materials, ideas and methods**. In: *Proceedings of the 1973 Conference on Prevention and Control of Oil Spills*, March 13-15, Washington, DC. American Petroleum Institute, Washington, DC, U.S., 559 p.
- Kana, T.E., E. Thompson, and R. Pavia. 1981. **Burmah Agate: Chronology and Containment Operations**. In: *Proceedings of the 1981 Oil Spill Conference*, March 2-5, Atlanta, GA. American Petroleum Institute, Washington, DC, U.S., pp. 131-138.

- Leveille, T.P. 1991. **The Mega Borg Fire and Oil Spill: A Case Study**. In: *Proceedings of the 1991 Oil Spill Conference*, March 4-7, San Diego, CA. American Petroleum Institute, Washington, DC, U.S., pp. 273-278.
- Mabile, N. 2012. **Controlled in situ burning: transition from alternative technology to conventional spill response option**. In: *Proceedings of the Thirty-fifth Technical Seminar on Environmental Contamination and Response*. Environment Canada, Ottawa, ON, Canada.
- McLeod, W.R. & D.L. McLeod. 1972. **Measures to Combat Offshore Arctic Oil Spills**. In: *Proceedings of the Offshore Technology Conference*, paper #1523 (2):14, pages 141-162.
- Michel, J., Z. Nixon, and H. Hinkeldey. 2005. **Use of In Situ Burning as an Oil Spill Response Tool: Follow-Up of Four Case Studies**. In: *Proceedings of the 2005 International Oil Spill Conference*, American Petroleum Institute, Washington, DC, U.S.
- Moller, T.H. 1992. **Recent experience of oil sinking**. In: *Proceedings of the Fifteenth Arctic and Marine Oilspill Program Technical Seminar*, June 10-12, Edmonton, Alberta. Environment Canada, Ottawa, ON, Canada, pp. 11-14.
- OSIR (Oil Spill Intelligence Report). Published weekly by Cutter Information Corp., 37 Broadway, Arlington, MA 02174-5539.
- Ramsier, R.O., G.S. Gantcheff, and L. Colby. 1973. **Oil Spill at Deception Bay, Hudson Strait**. Scientific Series No. 29, Inland Waters Directorate, Water Resources Branch. Environment Canada, Ottawa, ON, Canada.
- Robertson, I., J.R. McDonald, N.S. Robertson and L.B. Solsberg. 1976. **The Urquiola Oil Spill, La Coruna, Spain**. *Spill Technology Newsletter*, May-June 1976, Canadian Department of the Environment, Environmental Protection Service, Ottawa, ON, Canada.
- Robertson, I. 1991. **Operational Examples of In Situ Burning: Lessons from the Burning of Two Recent Diesel Spills on the B.C. Coast**. In: *Proceedings of the Fourteenth Arctic and Marine Oilspill Program Technical Seminar*, June 12-14, Vancouver, BC. Environment Canada, Ottawa, ON, Canada, pp. 411-419.
- Ruby, C.H., L.G. Ward, I.A. Fischer, and P.J. Brown. 1978. **Buzzards Bay Oil Spill - an Arctic Analogue**. In: *Proceedings of the International Conference on Ports and Ocean Engineering under Arctic Conditions (POAC '77)*, 4th Conference, St. John's, NF, Canada, 1977, Volume 2.
- Schrier, E. & C. Eidam. 1979. **Cleanup Efficiency of a Fuel Oil Spill in Cold Weather**. In: *Proceedings of the 1979 Oil Spill Conference*, March 19-22, Los Angeles, CA. American Petroleum Institute, Washington, DC, U.S. pp.419-427.
- Swift, W.H., C.J. Touhill, and P.L. Peterson. 1968. **Oil spillage control**. *Chemical Engineering Progress Symposium Series* 65(97):265-273.
- Turbini, W., E. Fresi and F. Bambacigno. 1993. **The Haven Incident: Lessons learned with Particular Reference to Environmental Damages**. In: *Proceedings of the 1993 Oil Spill Conference*, March 29-April 1, Tampa, FL. American Petroleum Institute, Washington, DC, U.S., pp. 179-183.
- United States Coast Guard (USCG). 2011. **BP Deepwater Horizon Oil Spill: Incident Specific Preparedness Review (ISPR)**, USCG, Washington, DC, U.S.
- Wardley-Smith, J. 1971. **Oil Pollution: Causes and Cures**. *Engineering* 211(6):644-648.

CHAPTER 3. FATE AND BEHAVIOUR OF OIL SPILLS IN ICE –AFFECTED WATERS

3.1 Introduction

This chapter has one main function: to describe the fate and behaviour of oil spills in various sea ice conditions with particular reference to factors that affect the ignition and burning of slicks on water and ice. This will help readers understand subsequent chapters that discuss the theory and practicability of in situ burning. For example, where following chapters indicate that in situ burning effectiveness decreases dramatically as oil spills emulsify, or that oil spilled under ice is not available for burning until the following spring, this chapter explains (briefly) the phenomenon of emulsification and the processes involved in oil encapsulation under a growing ice sheet and its subsequent appearance on melt pools during the melt season.

The behaviour of oil spilled in ice covered waters is governed largely by the ice concentration in the case of pack (or broken) ice and the processes of encapsulation and subsequent migration in the case of solid (fast) ice. Each season presents different drawbacks and advantages for in situ burning. During freezeup and breakup, drifting ice and limited site access tend to restrict the possible response options and can reduce removal effectiveness. Mid-winter, although associated with long periods of darkness and cold temperatures, provides a stable ice cover that not only naturally contains the oil within a relatively small area but also provides a safe working platform for surface oil removal. For the case of spills under or on fast ice, there are a range of effective burning options which can result in very high removal effectiveness. Options to deal with spills in moving pack ice are more limited and likely to result in highly variable removal values depending on a variety of natural conditions and logistical constraints. In these conditions it is often only possible to track the oil until it is released from the ice the following spring.

3.2 Petroleum Oil Characteristics

The fate, behaviour and effects of a marine oil spill are strongly influenced by the chemical composition of the oil being spilled. It is thus important to understand the characteristics of petroleum oils, especially crude oil itself because crude oil is the main target for an in situ spill burning operation. Much of the following brief description of petroleum oils has been abstracted from Buist *et al.* (1994).

3.2.1 Crude Oil

The chemical composition of crude oils from different producing regions, and even from within a particular formation, can vary tremendously. Crude oils contain thousands of different chemical compounds. Hydrocarbons are the most abundant compounds in crude oils, accounting for up to 98% of the total composition. While carbon (80-87% by weight) and hydrogen (10-15%) are the main elements in petroleum, sulfur (0-10%), nitrogen (0-1 %), and oxygen (0-5%) are important minor constituents. Crude oils also contain widely varying concentrations of trace metals such as V, Ni, Fe, Al, Na, Cu, and U. Vanadium and nickel, the most abundant metal constituents, can reach thousands of parts per million.

Table 3-1 presents three examples of the composition of crude oils. Petroleum hydrocarbons consist of alkanes, cycloalkanes, and aromatic compounds containing at least one benzene ring. The alkanes, or aliphatic hydrocarbons, consist of the fully saturated normal alkanes (also called

paraffins) and branch alkanes (iso-and cyclo-alkanes). Aromatic hydrocarbons, usually less abundant than the saturated hydrocarbons, contain one or more aromatic (benzene) rings connected as fused rings (e.g., naphthalene) or lined rings (e.g., biphenyl). The polynuclear aromatics with more than 3 rings consist mainly of pyrene, chrysene, benzanthracene, benzopyrene, benzofluorene, benzofluoranthene, and perylene structures.

Petroleum contains a significant fraction (0-20%) of compounds called asphaltenes which are of higher molecular weight (1,000 to 10,000), and which consist of both hydrocarbon and nitrogen-sulfur-oxygen compounds. In oil spill situations, asphaltenes contribute significantly to the oil's tendency to form water-in-oil emulsions. Specifically, asphaltenes, in association with similar but lower molecular weight compounds called resins, are surface active agents (surfactants) which promote emulsification when crystallized out of solution following evaporation of light hydrocarbons from an oil slick (Bobra, 1990; 1991).

Table 3-1: Chemical Composition of Three Crude Oils

Characteristics or Component	Prudhoe Bay	South Louisiana	Kuwait
API Gravity	27.8	34.5	31.4
Sulfur (wt %)	0.94	0.25	2.44
Nitrogen (wt %)	0.23	0.69	0.14
Nickel (ppm, mg/kg)	10.0	2.2	7.7
20-205°C Boiling Point Fraction (wt %)			
Alkanes	12.5	8.8	16.2
Cycloalkanes	7.4	7.7	4.1
Aromatic Hydrocarbons	3.2	2.1	2.4
Above 205°C Boiling Point Fraction (wt %)			
n-Alkanes (C11-C32 plus)	5.8	5.2	4.7
Isoalkanes	--	14.0	13.2
Cycloalkanes	28.5	37.7	16.2
Aromatic Hydrocarbons	25.0	16.5	21.9

NOTES: Table does not include polar compounds and asphaltenes. Source: World Health Organization. 1989.

The physical characteristics of crude oils that take on importance from a spill perspective are summarized as follows:

3.2.1.1 Volatility:

Crude oils contain a large proportion of light, volatile hydrocarbons (up to about C11-12) which quickly evaporate once exposed to the open environment.

3.2.1.2 Insolubility:

Generally, crude oil is insoluble in water. Most crude oils are also less dense than water and therefore float on water. Some compounds, such as low molecular weight alkanes and aromatics, are soluble in water, but only slightly.

3.2.1.3 *Spreadability:*

The surface tension of crude oil is such that virtually all petroleum oils spread on the surface of water. Exceptions are highly viscous oils and oils whose "pour point" (described later) is higher than the environmental (or ambient) temperature.

3.2.1.4 *Tendency to Emulsify:*

As noted, most crude oils contain natural surfactants (asphaltenes, resins) in sufficient concentration to cause an oil spill to emulsify at some stage during its time on the water surface.

3.2.2 *Refined Products*

Refined petroleum products include gasoline, kerosene, jet fuels, fuel oils (No.2, No.4, No.5, and No.6), marine fuel oils (Marine Gas Oils- MGO, Marine Diesel Oils - MDO, Intermediate Fuel Oils - IFO and Heavy Fuel Oils - HFO) and lubricating oils. Generally, refined products are not targets for an in situ burning programme because spills of heavier residual fuel oils are very difficult to ignite and slicks of the lighter products such as gasoline, kerosene and jet fuels are usually left alone to volatilise quickly to extinction. Only spills of middle distillates, the lighter fuel oils (No.2, MGO and MDO), may be reasonable candidates for burning, especially because of their tendency not to form water-in-oil emulsion (they do not contain asphaltenes and resins which have been removed during the refining process).

3.3 *Fate and Behaviour*

When oil is spilled at sea it is subject to several so-called weathering processes described schematically in **Figure 3-1**. The major processes that influence slick ignition and burning are drifting (advection), spreading, evaporation, natural dispersion of oil in water, and water-in-oil emulsification. These and the additional processes of dissolution, photolysis, and sedimentation influence the environmental and/or human-health effects of spills.

The physical distribution and condition of spilled oil under, within or on top of ice plays a major role in determining the most effective response strategies at different stages in the ice growth and decay cycle.

The fate and behaviour of oil in ice-covered waters is governed by a number of important processes, several of which are illustrated above in **Figure 3-1** (after Bobra & Fingas, 1986) and discussed below.

3.3.1 *Oil Spreading*

3.3.1.1 *On Ice and Snow*

The spreading of oil on ice is similar to spreading of oil on land. The oil density and viscosity control the rate of spreading, the final contaminated area being dictated by the surface roughness of the ice. Oil spilled on ice spreads much more slowly than on water and covers a smaller final area, thus slicks on ice tend to be much thicker than equivalent slicks on water.

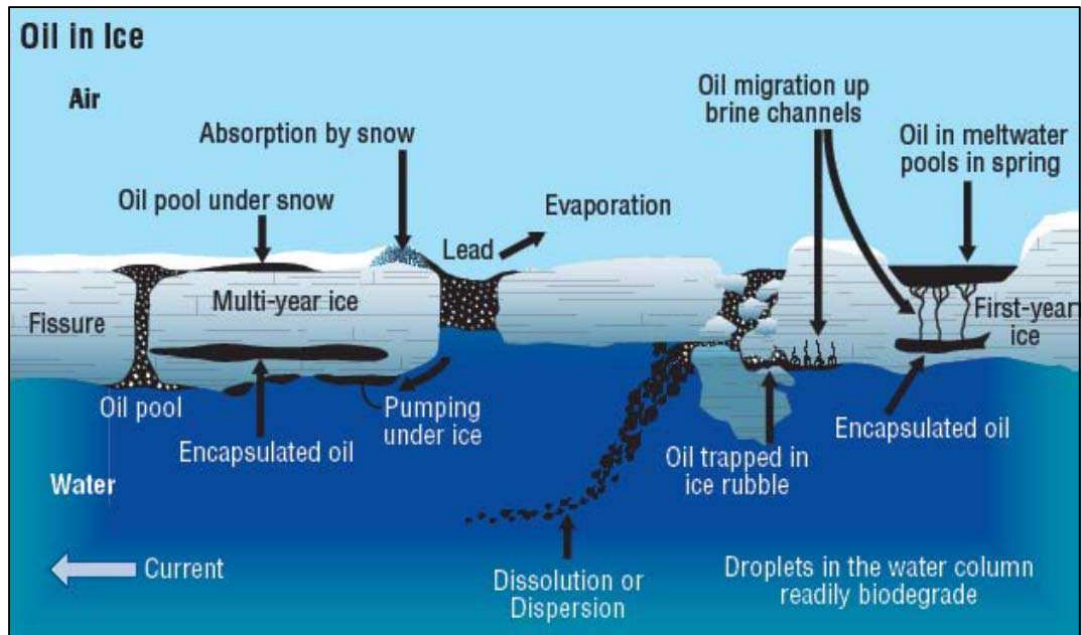

Figure 3-1 Illustration of Oil and Ice Processes (adapted from Borbra and Fingas 1981) (Source: ExxonMobil).

Glaeser & Vance (1971) present the results of a series of oil (diesel and North Slope crude) spreading experiments on sea ice near Barrow, AK. McMinn (1972) reports on a second series of releases of North Slope crude oil (some on snow-covered sea ice and some on bare lake ice) undertaken near Port Clarence in January 1972 and correlates the data using a modification of the Fay (1969) spreading model. Chen *et al.* (1974) conducted a series of radial spreading experiments on freshwater ice grown in a cold room with five different, low-pour point crudes and correlated the results with a gravity-viscous spreading regime model after Fay.

Figure 3-2 shows the final area of spills on ice as a function of spill size and ice roughness (after McMinn, 1972). Smooth first-year sea ice has a surface roughness in the 3 to 30-mm range. Discrete ice deformation features such as rafting, rubble and pressure ridges can lead to localized increases in roughness up to tens of metres in elevation above sea level (in the case of extreme grounded ridges along the seaward edge of the fast ice). Any oil spilled on the surface of rough ice may be completely contained in a thick pool bounded by ridge sails and ice blocks.

Generally, ice will be covered with a layer of snow, which will absorb spilled oil, further reducing its spreading (SL Ross & DF Dickins, 1988; Bech & Sveum 1991). Oil spilled onto a snow pack (if sufficient in volume) will flow down to the ice layer, and then spread slowly outwards under the snow.

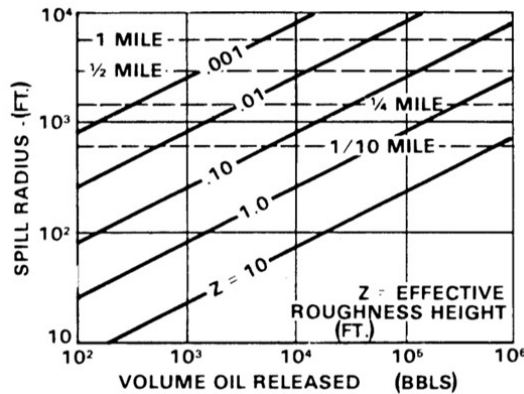

Figure 3-2 Predicted Spreading of Spilled Oil on Ice (McMinn 1972)
 (source: SL Ross Environmental Research)

Mackay *et al.* (1975) report on a series of small-scale laboratory and larger field studies of the behaviour of oil spilled on snow on terrain. Kawamura *et al.* (1986) carried out a series of experiments on the spreading of different chemicals, including mineral oils, in different types of snow, and correlated the results using Darcy’s Law. SL Ross & DF Dickins (1988) conducted mid-size experiments to measure oil spreading in snow on ice. Bech & Sveum (1991) report on a series of five large experiments with 1 m³ each of diesel and crude released onto or under snow on sea ice. SL Ross & DF Dickins (1988) reviewed all the work on oil spreading in snow up to that point in time (primarily Glaeser & Vance, 1971; McMinn, 1972; Chen *et al.*, 1974; NORCOR, 1975; Mackay *et al.*, 1975; and Kawamura *et al.*, 1986) and proposed, and verified with mid-scale experiments and other’s historical data, an equation for 2-D horizontal spreading of oil in snow from an instantaneous release. The model was confirmed in recent small-scale outdoor spreading experiments in snow (Buist *et al.*, 2008).

The type of release can have a large effect on the area of an oil spill on snow or ice. A surface blowout involving oil droplets and natural gas shooting high into the air can result in large areas around the blowout being coated with a thin layer of oil, with most of the oil falling near the source, but lesser amounts at considerable distances downwind (Nelson & Allen, 1982; Belore *et al.*, 1998). Batch oil releases will result in much thicker spills.

Table 3-2 shows a comparison of the predicted final areas covered by a 1,600 m³ (10,000 bbl) batch crude oil spill on open water, under solid sea ice and on smooth sea ice with and without snow. It is clear that the spreading of oil is greatly reduced by ice and snow, and the resulting slicks are much thicker than those on water.

Table 3-2: Spreading comparison for a 1600 m ³ (10,000 bbl) crude oil spill					
	Open Water*	Under Solid Ice		On Smooth Ice	
		December	April	Ice	Snow
Final avg. thickness (mm)	0.016	10	100.0	3	40
Final area (ha)	10,000.0	15	1.5	50	4

* Assumes a fluid oil spreading on quiescent water

3.3.1.2 On Cold Water

Glaeser & Vance (1971) also performed a series of one-dimensional spreading tests with Prudhoe Bay crude on a melt pool and compared the results with the Fay (1969) spreading theory. They observed that the slick stopped spreading before it thinned to sheen: an equilibrium slick thickness was reached. Fazal & Milgram (1979) showed in a series of small experiments that evaporation of oil can affect its spreading and explained the thick/thin phenomenon in crude oil spreading on water. Tebeau *et al.* (1984) performed a series of experiments to investigate spreading on cold water and among pack ice. SL Ross & Energetex (1986) conducted a series of one-dimensional spreading tests with several different oils and found that Fay's equation did not reasonably predict the results for viscous oils and suggested a "viscosity correction factor". SL Ross & DF Dickins (1987) proposed substituting oil viscosity for water viscosity in the Fay spreading models to better predict viscous oil spreading. SL Ross & DMER (1988) conducted a series on one-dimensional spreading tests with waxy and non-waxy oils at 5° and 10°C. They concluded that oil viscosity should be substituted for water viscosity in Fay's equations and that if the pour point of oil approaches ambient water temperature, spreading will cease. Timco & Davies (1995) performed a series of axi-symmetric spreading tests with paraffin oil, waxy crude and light crude on cold water and in ice with waves and wind. Buist *et al.* 2008 performed a series of one and two-dimensional spreading tests with a series of Alaskan crude oils with different physical properties and concluded that the data support the theory of Fay (1969) and Fay & Houtt (1971) that the oil spreading on water is not dependent on the viscosity of the oil, only the viscosity of the layer of underlying water set in motion by the spreading oil slick. The exception was for those oils at temperatures below their pour point, which did not spread at all.

3.3.1.3 Spreading Under Solid Ice

A combination of analytical studies, laboratory tests, and field spills, has been carried out to develop an understanding of the spread of oil, and gas, under an ice sheet. Laboratory tests have aided in understanding the processes involved and have produced data to define key spreading parameters (e.g., contact angle, interfacial tension). Field spills have provided information at a large scale which has helped to develop an overall understanding of the expected spreading behaviour.

The basic case of oil spreading under a smooth ice sheet has been studied in the laboratory and modeled by several researchers (Wolfe & Houtt, 1974; Keevil & Ramsier, 1975; Houtt *et al.*, 1975; Chen *et al.*, 1976; Yapa & Belaskas, 1993; and Ryttonen *et al.*, 1998). However, the under-surface of an ice sheet is rarely smooth and field spills have shown that the final under-ice configuration of spilled oil is usually dominated by the under ice topography.

Even large spills (thousands of cubic metres) of crude oil underneath solid (or fast) ice will usually be contained within short distances from the spill source, depending on under-ice currents and ice roughness. Natural variations in first-year ice thickness provide huge natural "reservoirs" to effectively contain oil spilled underneath the ice within a relatively small area. Late-winter (April with ice thickness usually > 2m) under-ice storage capacities have been estimated to be as high as 60,000-m³ per km² from surveys of fast ice along the Alaskan North Slope (Kovacs, 1977; Barnes *et al.*; 1979; Kovacs *et al.*, 1981; Comfort, 1986; Goodman *et al.*, 1987). Early winter ice thickness values have been computed to be about one half as great, reflecting the smoother ice at that time. Sub-Arctic regions with greater snowfalls (e.g., Labrador) would be expected to have a greater local variability in ice thickness earlier in the

season. The implication is that any winter spill under ice would be naturally contained within a relatively minute area when compared with an identical volume spilled on open water. As the natural containment increases with ice thickness, the area needed to contain a given spill volume decreases steadily throughout the winter, as shown in [Figure 3-3](#).

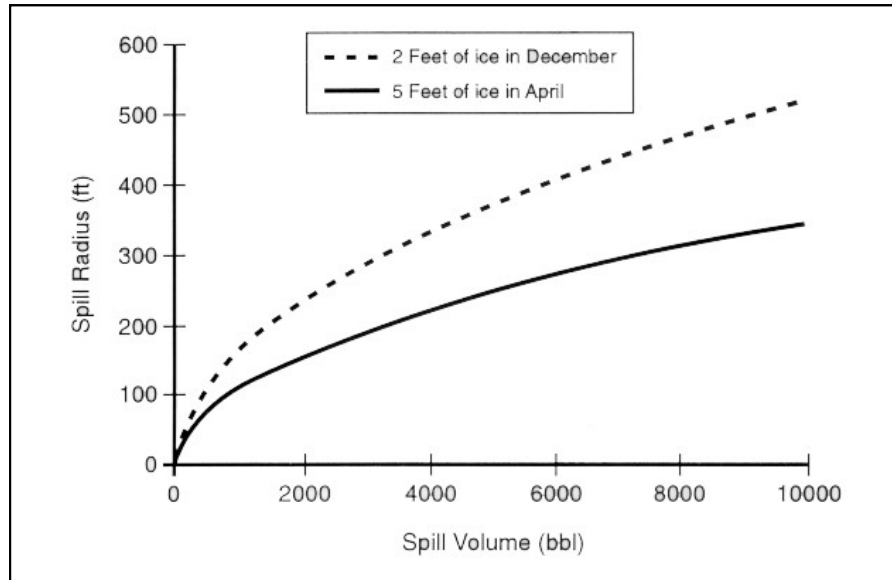

Figure 3-3 Predicted Radii of Spills of a Given Volume Spilled Under Landfast Ice (Dickins and Glover 1996. (Source: D. Dickins)

In August 2004, an Autonomous Underwater Vehicle (AUV) took multi-beam, three-dimensional sonar measurements of the underside of a first-year landfast ice sheet that was 1.3-m thick (Wilkinson *et al.*, 2007). Using the older method of calculating (which assumes all the void spaces available completely fill with oil) the under-ice oil-holding capacity of the sheet was estimated to have a mean pooling capacity of 30,000 m³/km². Using a different model that assumes that spilled oil will progressively fill (by gravity-driven flow) only those void spaces that have flow pathways connecting them gave a result of 2,000 m³/km², an order of magnitude lower. The mean pooling capacity model predicts 50% of the ice sheet area would contain oil while the gravity-driven flow predicts 6%. The AUV result was obtained by measuring only the large-scale under-ice features, and did not consider the “roughness” of the underside of sea ice due to growing ice crystals and small deformations. It is possible that oil released under sea ice would never spread to the areas predicted by the gravity-driven flow model because the oil would cease spreading due to the smaller under-ice roughness.

The maximum average oil layer thickness under sea ice can range from several centimetres for spills in early winter to tens of centimetres in April for a spill under ice at the end of the ice growth cycle. The maximum oil thickness in the deepest pools could vary from 10 to over 30-cm, respectively. Actual values will depend on the local ice conditions at the time of the spill.

Another important factor in determining the thickness of oil under ice is the character and flow rate of the oil release. If a subsea blowout involving significant quantities of gas occurs in pack ice, oil may be “painted” as individual droplets on the underside of the ice as it passes over the well site, and the average oil thickness under the ice could be much less than that predicted by the under-ice holding capacity.

Laboratory tests have been conducted to investigate the resulting configuration when oil and gas are released together under an ice sheet (e.g., Purves, 1978; Kisil, 1981). The observed configurations include an oil-coated gas bubble, gas bubbles with oil on their sides and bottom, and separate sessile drops of oil and gas. When oil and gas was released under ice in the field (at McKinley Bay, N.W.T.), the following configurations were observed (Dickins & Buist, 1981):

1. Oil droplets;
2. Gas bubbles with a coating of oil; and,
3. Large pools of oil underneath gas pockets.

Dickins & Buist (1981) reported that most of the oil was distributed as oil droplets and gas bubbles (i.e., configurations 1 and 2) for the case when the oil was released under relatively thin ice (which was also relatively flat). For spills carried out later on in winter, when the ice was relatively thick and rough, most of the oil and gas was contained in the under-ice pockets (i.e., configuration 3).

Three general spreading models were developed to predict the fate and behaviour of oil and gas released beneath an ice sheet (NORCOR, 1977; Wotherspoon *et al.*, 1985; and Comfort, 1986). The NORCOR (1977) and Comfort (1986) models assume that the oil and gas will fill the under-ice depressions uniformly with pockets of gas underlain by an oil film. The area of contamination is computed based on the volume of the spilled oil and gas, and the available under ice storage volume.

Natural variations in ice thickness comprise the most important physical ice characteristic limiting the spreading of oil from a sub-surface release. In the case of a small leak, the formation of a lip of new ice at the outer perimeter of the spilled oil will also act to further limit spreading in the case of unusually smooth ice.

The density of oil spilled into a crack, or hole in land fast ice can dictate how it will behave. The density of sea ice is generally in the range of 0.95 g/cm³ and the density of seawater is in the 1.01 to 1.02 g/cm³ range. Fresh crude oils range in density from 0.8 to 1.0 g/cm³. Allen & Nelson (1981) discuss how oil spilled in a hole, or small lead, can by virtue of the density difference between oil and ice, either flow underneath an ice sheet or overflow onto the ice surface as oil fills the hole, and how brash and slush ice will tend to float at the oil-water interface in thick spills of lighter oils.

3.3.1.4 Spreading In Pack Ice

In pack ice-covered waters, oil spills tend to spread far less and remain concentrated in greater thicknesses than in ice-free waters. In ice concentrations greater than "close pack" (exceeding 6 to 7/10ths of the sea surface with ice), the ice floes touch and provide a high degree of natural containment thereby limiting the spread of oil. As ice concentrations become more open, oil spreading gradually increases until it reaches close to an open-water state in very open drift ice (3/10ths ice coverage or less).

Free *et al.* (1982) investigated the spreading of spilled oil in "broken" ice in a series of laboratory experiments. Tebeau *et al.* (1984) conducted a series of larger experiments to identify the mechanisms of oil spreading in "broken" ice and to verify the equations proposed by Free *et al.* (1982).

SL Ross & DF Dickins (1987) conducted three experimental spills in pack ice off the coast of Cape Breton, Canada. Each involved 1 m³ of crude oil to evaluate spreading, evaporation, emulsification, dispersion and incorporation into ice and countermeasures. They concluded that the spreading of oil in pack ice was dramatically reduced by ice and proposed a simple spreading model involving the ice cover percentage. They also concluded that, in open drift ice, oil and ice moved together at about 3% of the wind speed and 10° to the right of the wind direction plus the prevailing current.

Belaskas & Yapa (1991) carried out a series of spreading tests in a small tank to examine the relationship of discharge rate and oil volume on the spreading rate in “broken” ice. In 1993, following a series of test tank experiments, an experimental spill involving 26 m³ of North Sea crude took place in the Barents Sea marginal ice zone off the coast of Norway (Singsaas *et al.*, 1994; Reed & Aamo, 1994; Jensen, 1994). It was concluded that the high concentrations of pack ice (90% initially, declining to 75% at the end of the experiment) during the field experiment kept the oil thick and immobile for an extended period of time (days) which, in combination with cold temperatures and the damping of wave action by the ice, significantly slowed oil weathering processes (evaporation, natural dispersion and emulsification). Brandvik *et al.* (2004) presents a comparison between the results obtained from the experimental spill in pack ice with a similar experimental spill in open water.

Other tank tests of oil spreading under and in pack ice features have been reported by: Sayed & Ng (1993), who experimented with small (3 litre) slicks of Amauligak, Hibernia and Norman Wells crude in various brash ice concentrations; Weerasuriya & Yapa (1993) who experimented with spreading of oil under ice floes in a small tank; Yapa & Belaskas (1993), who experimented with spreading of oil under and over simulated pack ice fields in a small tank; and Gjosten & Loset (2004) who measured spreading rates of IFO-30 and Marine Diesel in various concentrations of slush ice in different mixing energies. All these research programmes confirmed that the presence of pack ice significantly slowed oil spreading.

There are a number of simple empirical models that predict the spreading of oil in pack ice by modifying open-water spreading (Figure 3-4) as a function of ice concentration. For example, a 1000 m³ spill in 6/10ths ice cover after 12-hours would be estimated to have spread to 0.8-km² (2-km² from Figure 3-4 multiplied by 0.4 (1-6/10) – after SL Ross & DF Dickins, 1987).

In 1990, the Atmospheric Environment Service of Environment Canada undertook a study of oil spreading in pack ice (Venkatesh *et al.*, 1990). They developed empirical methodologies for computing the spread of oil based on the equilibrium thickness of oil on cold water and in slush ice. They reported good agreement with the field test data available at the time. The model was further refined to account for the observed spreading rate dependency on oil viscosity, net surface tension, and slush ice particle size (El-Tahan & Venkatesh, 1994).

A model was developed in Finland (the Atmospheric Environment Service of Environment Canada also participated) to predict the movement, fate and weathering of oil spills in Baltic Sea ice conditions (Hirvi *et al.*, 1992). The known movements of the oil from the *Antonio Gramsci* spill in 1987 were used to test the model. It was concluded that the model could calculate the general patterns of oil transport and spreading but that the lack of ice data limits the accuracy of the simulations. The small-scale interactions of oil and ice were not described by the model (the resolution employed was a four-kilometre grid).

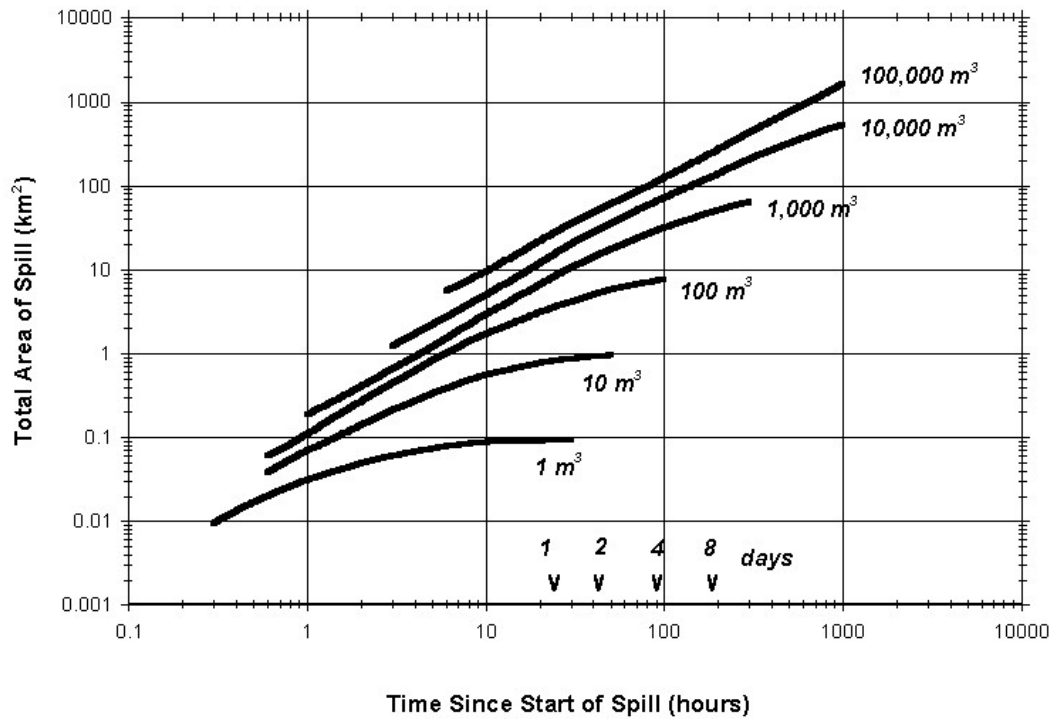

Figure 3-4 Predicted Spreading of Spills on Open Water. (Source: SL Ross Environmental Research)

The experimental data generated by Weerasuriya & Yapa (1993) and Yapa & Belaskas (1993) was used to develop a numerical model of oil spreading in pack ice (Yapa & Weerasuriya 1997). The spreading data from a 7 m³ experimental spill in the Barents Sea was incorporated into SINTEF’s oil weathering model (Sorstrom et al., 2010).

3.3.2 Oil Movement

Spills on and under ice will generally not move independently of the ice, but remain in the vicinity of the spill site; if the ice is drifting, the oil will drift with it. One exception to this is oil under ice in currents exceeding 15 to 20 cm/s (0.3 to 0.4 knots). The rate at which oil moves under ice under the influence of high currents generally involves the progressive filling and draining of under-ice cavities with oil. In general, the oil is swept under the ice until it has filled enough under-ice cavities to account for the volume spilled.

Winter under-ice currents in most Arctic near shore areas are not sufficient to spread spilled oil much beyond the initial point of contact with the ice under surface. Exceptions may be in fiord-like areas with strong tidal currents. There have been a large number of laboratory studies of oil spreading and movement under ice. Moir & Lau (1975) report a series of tests using Plexiglas ice “keels” in a flume to determine failure velocities for slicks beneath an ice surrogate (expanded foam insulation sheets covered with vinyl). Chen et al. (1976) and Tsang & Chen (1978) report on a series of experiments to measure the velocity of oil under river ice, and possible deflection techniques. Uzner et al. (1979) report a series of flume experiments to measure the stripping velocity (the current speed at which the oil began to move under the ice) and subsequent advection of oil slicks. This is considered the seminal study on the effects of under-ice currents on oil movement. Smooth, freshwater ice was used in the flume, along with crude oil and No. 2

fuel oil. Cox & Schultz (1980) and (1981) report on experiments in the same flume to assess the advection of oil under ice in the presence of large, under-ice roughness features. Cammaert (1980) describes a series of tests to determine the stripping velocity of oil spilled with natural gas under sea ice as a function of under-ice undulation amplitude. Puskas *et al.* (1987) and Puskas & McBean (1986) report a series of experiments in a flume with fresh and saltwater ice conducted to determine the drag coefficient of oil slicks under ice and the effects of oil and ice parameters.

Dickins & Buist (1999) summarized the results of this body of earlier work: with roughness values typical of undeformed first-year sea ice, the threshold current speed needed to initiate and sustain movement of an oil lens or pool along the ice under surface is approximately 20 cm/sec.

The influence of ice salinity on under-ice oil spreading (stripping velocity, roughness effects, etc.) had not been studied in any systematic manner until recently. One of the key references used to predict the threshold current velocities needed to initiate and sustain movement of oil under sea ice (Uzner *et al.*, 1979) was based on the use of freshwater ice sheets to perform the experiments (with different degrees of superimposed artificial roughness). Malcolm & Cammaert (1981) used a saline ice cover (salinity not specified) but focused entirely on the effect of gas entrapped in thin ice areas on the oil spreading behaviour. Puskas *et al.* (1987) and Puskas & McBean (1986) report a separate series of experiments in a flume with fresh and saltwater ice carried out to determine the drag coefficient of oil slicks under ice and the effects of oil parameters. Hollebone *et al.* (1998) plotted the two sets of test data. Their comparison indicates a significantly lower velocity for slicks beneath ice grown from 30‰ salt water than under fresh water ice at a given current.

A series of experiments was recently carried out (Buist *et al.*, 2008) in a recirculating flume tank beneath ice sheets grown to simulate real under-ice surfaces, which feature gentle undulations and a soft crystalline underside. Parametric studies were carried out, varying oil type, water salinity, under-ice roughness, and current speed. The measured stripping velocity was in the 4 to 6 cm/s range under the smooth, freshwater ice (as reported by Uzner *et al.*, 1979; Cox & Schultz, 1980). There was no significant effect of oil properties on the “stripping” velocity under freshwater ice for the small oil forms tested. The speed at which the oil forms moved under the freshwater ice, once started, was approximately 10 to 20% of the measured current speed, with no apparent correlation between oil form size and crude type with speed. As the freshwater under-ice roughness increased the stripping velocity increased dramatically. Beneath undulating freshwater ice the stripping velocity ranged from 5 to 20 cm/s and the crude properties appeared to have some effect. Under the refrozen rubble ice the stripping velocity increased again, with measured values ranging from 16 to 30 cm/s. Once moving the oil proceeded at about 6 cm/s, with no apparent effect of oil type or current speed. As the salinity of smooth ice increased the stripping velocity also increased. There was no significant observable effect of salinity on the speed of the oil forms after they had begun moving. There appeared to be a similar effect of increasing salinity causing increasing stripping velocity beneath undulating ice sheets, but not surprisingly, the roughness of the refrozen rubble ice sheets masked any effects of ice salinity on “stripping” velocity.

Oil spilled among higher concentrations (greater than 5/10ths) pack ice will move with the ice. Both the ice floes and the oil will move at a small percentage of the wind speed (SL Ross & DF Dickins, 1987). A value of 2 to 3% of the wind speed is commonly used as a general rule to estimate floe drift speed, but floe-tracking experiments have shown that a value of 5 to 7% is

not uncommon near shore in Prudhoe Bay, AK (Tekmarine, 1984). Due to the Coriolis effect, a turning angle of 10 to 20° to the right of the wind can be applied to better estimate the direction of oil moving with high concentrations of ice. At lower ice concentrations (less than 3/10ths) the oil and ice move at different rates under the influence of wind. The generally accepted factor for the influence of wind on oil slicks is 3.5% (Nerella & Jarvis, 1980); ice floes move downwind at 2 to 3% of the wind speed, with the factor averaging about 2.5% (Dickins *et al.*, 1986; Venkatesh *et al.*, 1990). As such, oil can move slowly downwind through loose drift ice. Oil trapped in converging pack ice, will be thickened as the ice concentration increases; in extreme cases, rapid compression can force some of the oil from the water to the upper or lower surfaces of adjacent floes (MacNeill & Goodman, 1985). The majority of the oil that was floating on the water or in frazil/slush ice between floes prior to compression will be incorporated into the raised crushed ice edges as the floes contact and grind against one another under the wind-generated pressure.

The oil spill trajectory model OILMAP was used to forecast trajectories of oil in pack ice for the 1993 spill in the Barents Sea marginal ice zone by SINTEF (Reed & Aamo, 1994). The model performed reasonably well early in the spill when the winds were from the ice towards the open water (off-ice) and ice concentrations were 60% to 90% by applying a 2.5% of wind speed drift factor and an Ekman veering angle of 35° to the right (in open-water spill modeling these parameters are normally 3% to 3.5% and 10° to 20°). When the wind changed to on-ice, a wind factor of 1.5% and a veering angle of 60° worked best.

3.3.3 Oil Encapsulation and Migration

For a release of oil beneath growing sea ice, new ice will completely encapsulate the oil layer within 18 to 72-hours, depending on the time of year. Oil spilled under the ice after May in the Arctic, or after April in sub-Arctic regions, may not become encapsulated before the onset of melt due to insufficient new ice growth.

Once oil has stopped spreading under the ice, it will begin to be incorporated by the downward-growing ice sheet. This has been observed in all laboratory and field experiments, including those involving oil and gas. **Figure 3-5** shows oil encapsulated in a 1.5-m thick slab of sea ice excavated from an experimental spill in Alaska. The first step in the encapsulation process is the formation of an ice lip around the oil (and/or gas). The oil and gas is eventually completely encapsulated by the ice sheet, either by ice growth in from the lip to the center of the pool of oil or by heat transfer down through the pool causing new crystal growth beneath the oil.

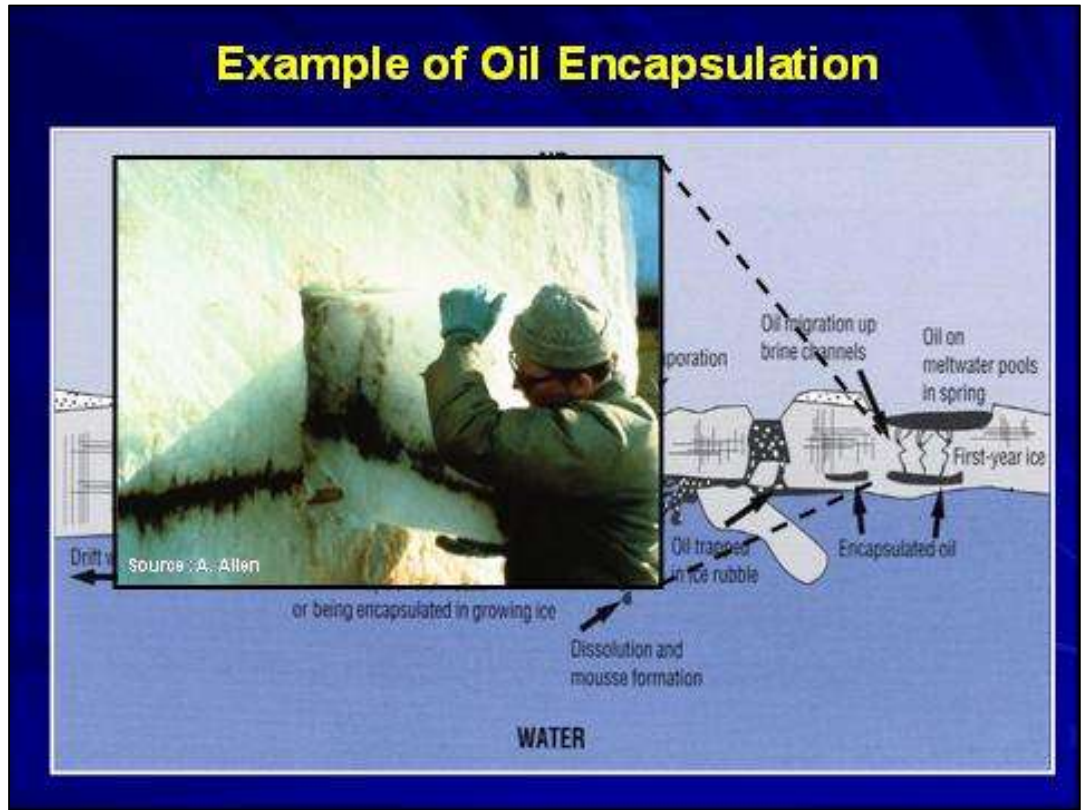

Figure 3-5 Oil encapsulated in a 1.5-m thick slab of sea ice excavated from an experimental spill in Alaska. (Source: A. Allen)

3.3.3.1 Oil Under First Year Ice

Several researchers have studied the encapsulation process in the laboratory (Wolfe & Hout, 1974; Keevil & Ramsier, 1975; Chen *et al.*, 1976; Purves, 1978; Kisilm, 1981; Payne *et al.*, 1984) but the seminal work on the subject was a field experiment by NORCOR (1975). They observed that the ice formed a lip around the edge of even the thickest oil in a matter of hours and the oil was completely encapsulated in a few days. Once entrapped the oil was stabilized until spring, with the properties of the oil unchanged.

After oil has spread under the ice and been encapsulated, it will remain trapped until the ice sheet has reached its maximum thickness, at which time a process of vertical migration will begin with the gradual warming of the ice sheet. The rate of vertical migration depends on the degree of brine drainage within the ice (a function of internal temperature), trapped oil pool thickness, and oil viscosity. During the period from freeze-up to mid-winter when the sheet is cooling and growing rapidly, there are very few passages for the oil to penetrate into the ice sheet. Vertical migration of the oil in this period is limited to several centimetres of initial penetration through the porous skeletal layer (new ice crystals) at the ice/water interface. As ice temperatures gradually increase, brine trapped between the columnar sea ice crystals begins to drain down, leaving vertical channels for the oil to eventually rise to the surface. The first evidence of natural oil appearance on the surface has been observed as early as late May in experiments off the Beaufort Sea coast. In sub-Arctic areas such as Labrador, this process will be advanced by about one month depending on air temperatures. Oil released beneath two

metres of ice in one experiment on May 21 reached the ice surface within one-hour (NORCOR, 1975).

The Balaena Bay Project involved a series of spills under sea ice over the course of one winter (1974/75) and represents the most detailed historical study of crude oil migration (NORCOR, 1975). Oil spilled in early winter remained static as a discrete lens until February, at which time the ice surface temperatures gradually raised from -20°C to -12°C . The transient reduction in temperature gradient combined with increased ice salinity immediately above the oil lens, led to an initial migration of 10 to 15-cm even in mid-winter while new ice was forming rapidly beneath the oil layer. During the winter period, the vertical depth of the main oil lens at the time of the spill had little or no effect on the extent of migration.

During March and April, the brine channel network within the ice sheet became progressively more connected and the oil gradually rose through the sheet to within 10 to 15-cm of the surface layer. The average brine channel diameter at this point was 4-mm. The final penetration to the surface was blocked for a short time by the upper layer of clear frazil ice that lacked a cohesive brine channel network (randomly oriented crystals) but once air temperatures remained consistently above freezing, oil from all the test sites broke through to the surface with a similar timeline, regardless of the depth of oil within the ice.

The rate of oil migration increases rapidly once daily air temperatures remain consistently above freezing. During the same experiment, up to 50 percent of the oil originally trapped within the ice became exposed on the ice surface between June 10 and June 20. Oil slick thickness in the melt pools on the surface increased from 1-mm to over 10-mm during a one-week period. Once oil reaches the ice surface, it lies in melt pools or remains in patches on the melting ice surface after the surface waters have drained. Winds herd the oil into thicker layers against the edges of individual pools.

Nelson & Allen (1982) reported observations from a series of 18 spills of diesel and crude under natural first-year ice from 15 to 57-cm in thickness. All of the diesel spills migrated very quickly, never having time to form trapped lenses in the ice. Crude oil tended to migrate to the surface earlier than at Balaena Bay (described above). The difference in behaviour was linked to the presence of abnormally deep snowdrifts over the spill sites, resulting in internal ice temperatures more typical of spring conditions.

Dome Petroleum sponsored an experiment involving three spills of Prudhoe Bay crude with compressed air under fast ice during the winter of 1979/80 at McKinley Bay NWT. Much of the oil appeared on the surface in June, as the ice surface ablated to expose the trapped oil layer (**Figure 3-6**). Brine channel migration was much more pronounced in the spill where the gas volume was substantially lower (quickly leading to defined oil pools as opposed to scattered oil particles under the ice). The greater oil viscosity was also thought to be a factor in explaining the difference in migration behaviour from the earlier spill at Balaena Bay. The presence of gas injected with the oil had a major effect in decreasing or eliminating the process of oil migration. The McKinley Bay spills showed that trapped oil residing as widely scattered droplets within the ice is only exposed in large volumes when the surface has completely melted down to the level of the originally trapped oil (Dickins & Buist, 1981). **Figure 3-7** shows the timing of oil exposure as measured from the three different experimental sub-sea blowout spills during the course of one winter (Dickins & Buist, 1981).

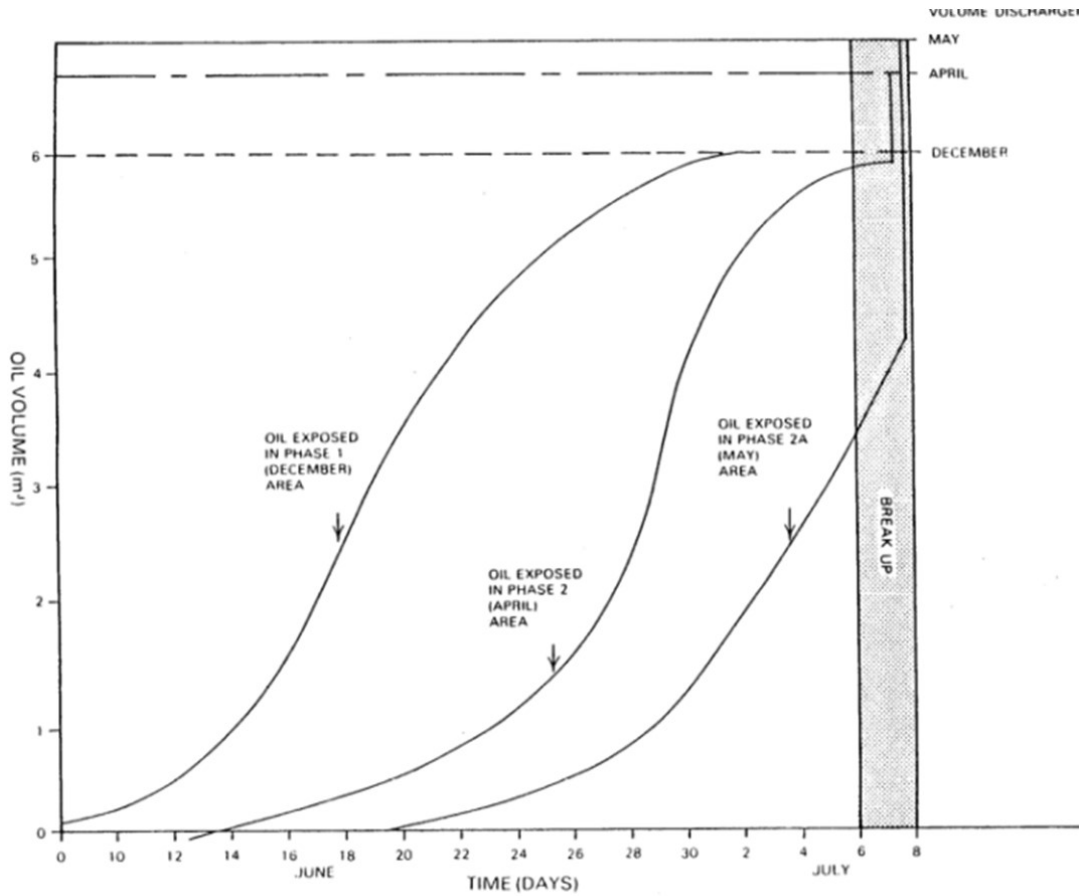

Figure 3-6 Initial Surface Appearance of Crude Oil Migrating Through the Ice at the Dome Oil and Gas Under Sea Ice Experiment in Early June 1980. (Source: D. Dickins)

Natural melt of ice from the surface down (called ablation) acts as a competing process to expose encapsulated oil. When ablation reaches the level where the ice was growing at the time of the spill, the oil is exposed. In most situations of a concentrated thick, low-viscosity oil layer in ice, natural migration will bring most of the oil to the surface before the surface melts down to meet it. Oil released subsurface in the presence of gas (e.g., blowout) may be distributed as fine droplets which surface much more slowly. Both processes are combined in [Figure 3-7](#). The exposure of encapsulated viscous oils and emulsions will likely be by the process of ablation (Buist *et al.*, 1983).

A series of experiments on oil spilled under ice floes typical of the Sea of Okhotsk were undertaken in the late 90s and early 00s (Ohtsuka *et al.*, 1999; Ohtsuka *et al.*, 2001). The results showed that oil will progressively fill under-ice cavities on the bottom of the ice floes and that compressed gas (air) released under the floe will displace the oil. Only a small amount (less than 1%) of the oil will permeate up to the surface of a 7 to 10-cm thick floe.

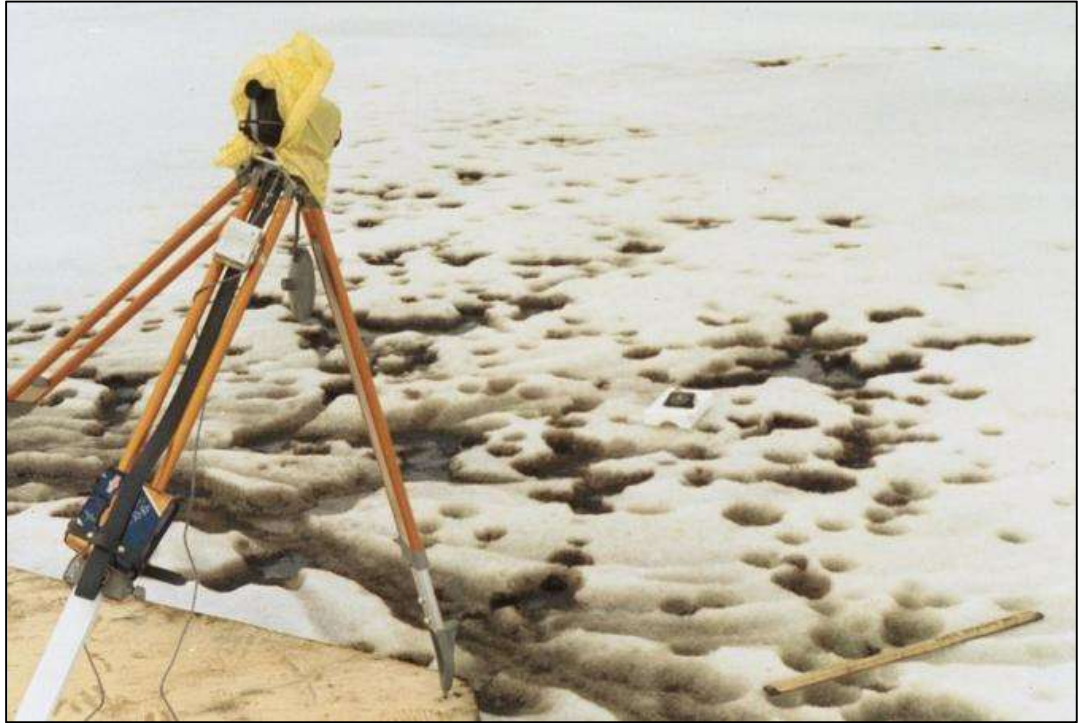

Figure 3-7 Rate of Oil Exposure From Beneath Sea Ice Originating From Three Simulated Sub-sea Blowouts (Dickins & Buist 1981). (Source: SL Ross Environmental Research)

Dickins *et al.* (2008) describe a recent experimental spill conducted with SINTEF and UNIS on Svalbard in March 2006 and the subsequent documentation of oil behaviour. Ice thickness averaged 65-cm at the time of the spill and the spill volume was 3.4 m³ inside a 100 m² circular area contained within a plastic skirt. The weathering of the oil under the ice with respect to vertical migration, evaporative loss and water content was monitored through oil and ice sampling at regular intervals throughout the field period. The oil was first observed on the ice surface under the snow inside the skirted area on April 20th after 24 days under the ice (March 27th to April 20th). The rate of bulk oil migration through the ice was monitored by visual inspection of the ice and by analyzing the oil content in ice cores.

The rate of oil surfacing observed in this experiment on Svalbard (Figure 3-8) makes an interesting comparison with the Dome oil-under-ice experiment in the Canadian Beaufort Sea carried out in 1979/80. Oil from the first spill in that experiment rose through a similar ice thickness (60 to 70-cm) to reach 100% exposure in approximately 40 days from first appearance under the snow, results very similar to the timing of oil appearance documented at Svea in Svalbard.

Numerous other researchers have conducted laboratory and tank tests on oil migration through sea ice to complement the limited number of field spills in natural sea ice. Selected examples are highlighted briefly here.

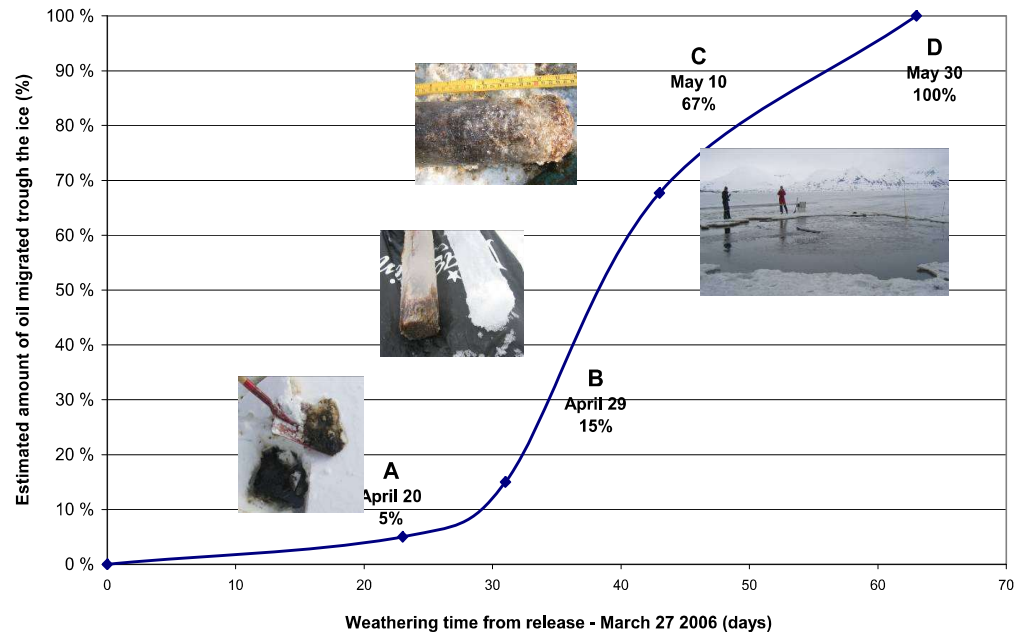

Figure 3-8 Estimated Amount of Oil Penetrated through the Brine Channels in the Ice and Available on the Ice Surface during SINTEF's Experimental Spill Under Ice in 2006 Photos show appearance of cores at different stages in the migration cycle. (Source: SINTEF/UNIS)

Purves (1978) presents the results of spilling crude oil and methane gas under laboratory grown saline ice. Oil and gas were rapidly released from the sheet when the minimum ice temperature reached -3.6°C . Kisil (1981) conducted a series of small-scale experiments using an 11-litre (0.7 bbl) aquarium, adding oil after first releasing air under the ice. She developed an expression to predict the oil migration rate as a function of ice thermal conductivity, temperatures at the surface and depth of the oil layer, and distance from the trapped oil to the surface. She found that the sheet became porous first to gas and then oil, once the minimum ice temperature reached between -2° and -6°C .

Payne *et al.* (1984) examined the chemical and physical weathering behaviour of oil released under a thin sheet (8-cm grease/frazil underlain by 8-cm columnar ice) of simulated first-year ice in a refrigerated tank. Once a 5-mm layer of solid columnar ice beneath the oil encapsulated the spill, a thaw cycle was initiated to promote migration. Oil flow rates through the brine channels were measured and compared with theoretical predictions by Cox & Schultz (1980). Cox calculated the minimum brine channel that would allow effective oil migration in seawater as a function of oil/water interfacial tension, contact angle, oil lens thickness, and oil density. The calculated channel diameter in the case of Payne's experiment was 3.6-mm that agrees well with field observations at Balaena Bay (NORCOR 1975). The rise velocity was determined to be 0.35 mm/sec, agreeing reasonably with an experimental value of 0.7 mm/sec determined by Martin (1979), based on observations of oil rising through 2-m of ice in May 1975 at Balaena Bay. Dickins *et al.* (2005) describes recent experiences with oil spilled beneath a 40-cm sheet of urea ice (artificial sea ice mimicking the natural crystal structure) at CRREL. These tests demonstrated that significant (15 to 18-cm) vertical migration of a low viscosity crude (in this case South Louisiana) could occur within a young, growing ice sheet while air temperatures are

still well below freezing (in this case -17°C). Internal ice temperatures at the upper level of oil migration were in the range -3 to -4°C .

Buist *et al.* (2008) conducted a series of tests in outdoor tanks with four Alaskan crude oils to measure migration rates of spilled crude oil through ice sheets with different salinities. The results were:

- The most rapid migration rate was clearly associated with the lightest, least viscous oil and ice formed from 30‰ water. This finding makes intuitive sense in that ice formed from true seawater has a higher area density of brine channels than brackish ice and the oil with the least viscosity and density will move more freely through those channels to the surface.
- The lowest migration rate (essentially zero) was associated with the oil having by far the greatest viscosity and density. In this case, there was no migration in the true sense of the word, and exposure of the oil all took place in the last few days of the project when the ice melted sufficiently from the surface to expose the oil still trapped at its original position in the sheet.
- The medium-gravity crude in ice formed from 30‰ water experienced a slower migration rate than the lighter crude in similar ice

High concentrations of sediments in ice routinely occur through a variety of processes thought to include ice keel gouging, flotation by anchor ice releasing from the bottom, direct freezing to the seabed in shallow water with subsequent re-floating, and entrainment of suspended sediments in frazil ice throughout the water column. Sediments incorporated within the ice sheet will potentially affect the light transmittance (with potential effects on solar gain and temperature-related oil migration in the spring), mechanical strength and possibly other parameters.

Buist *et al.* (2008) also conducted a study that examined effects of incorporated sediments on vertical oil migration. The combination of low salinity water and sediment produced the lowest migration rate. The 12 to 15-cm cap of frazil ice (with no vertically oriented columnar crystals to provide brine channels) in the sediment tanks likely played an important role in blocking or inhibiting oil migration for the first three weeks of the melt cycle (mid-March to early April).

3.3.3.2 Oil Spilled under Multi-year Ice

Oil spilled under old ice (either second-year ice or multi-year ice) will be retained by under-ice roughness features, as it would be under first-year ice. The under-ice oil storage capacity of old ice appears to be greater than under smooth first-year ice, and individual pools of oil may be very thick (pools 19-cm thick have been measured; Comfort & Purves, 1982). The downward growing ice sheet would gradually encapsulate the oil over winter, albeit more slowly than under first-year ice due both to the thicker ice and the thicker oil pools. The encapsulated oil would not weather significantly while sandwiched in the old ice sheet.

Despite the lower salinity of old ice, during the following melt season, the oil would migrate through brine channels to the surface of the old ice (Milne *et al.*, 1977) and appear in the melt pools on the surface, albeit likely later in the melt season than for first-year ice and at a slower rate. Field experiments (Comfort & Purves, 1982) showed that three pools of crude oil placed under old ice 2.5 to 2.9-m thick in the Canadian High Arctic on June 1, 1978 had appeared on the ice surface by August 20, 1978. Cores taken October 13, 1978 in two of the oiled areas indicated that the oil had surfaced. A site visit in September 1979 showed that 90 to 99% of the

oil originally placed under the old ice had surfaced. The surface oil remaining at the site was heavily weathered. A survey of the site in September 1982 found no oil.

3.3.4 Oil Weathering

The major weathering process that occurs for spills on ice or among pack ice is evaporation. Oil evaporation rates on ice, in leads and among pack ice are generally slower than for spills on open water. This is because the temperatures are lower in ice situations, and the oil slicks are much thicker. The presence of a snow cover also greatly reduces the evaporation rate of oil. Ultimately, spills on or among ice will reach the same final degree of evaporation as spills on water.

3.3.4.1 Evaporation

3.3.4.1.1 Evaporation on Ice at Low Temperatures

Glaeser & Vance (1971) present the results of a series of crude oil evaporation experiments on sea ice and melt ponds at average temperatures of 3.3°C near Barrow, AK. Chen (1972) and McMinn (1972) report on the evaporation of a series of releases of North Slope crude oil (some on snow-covered sea ice and some on bare lake ice) undertaken near Port Clarence in January 1972 during which the temperatures were in the -25° to -9°C range. Tebeau *et al.* (1982) present the results of a series of weathering experiments with Prudhoe Bay crude on ice conducted in Groton, CT during December and January 1980/81. At most times the temperatures were below freezing. Stiver & Mackay (1983) present the “Mackay evaporative exposure” model for estimating hydrocarbon evaporation rates. This approach has become a standard in oil spill modeling. SL Ross & DF Dickins (1987) report evaporation rates for crude oil released on ice at -10°C. SL Ross & DMER (1988) and Berger & Mackay (1994) discuss how to modify the classic Mackay evaporation algorithms to account for the development of internal resistances to mass transfer due to increasing viscosity and gelling of higher pour point slicks. Fingas (1994) presents the results of parametric tests with one crude oil evaporating at temperatures ranging from -20° to 40°C. SL Ross (2003) presents the results of evaporating a Russian crude oil at temperatures ranging from -20° to 0°C. Buist *et al.* (2008) report on experiments that were carried out on an ice sheet grown from 35‰ salt water in a refrigerated wind/wave tank. The tank was maintained at nominal temperatures of -10°, -20° and -30°C. The results were used to select the most suitable mathematical model for sub-freezing evaporation of oil spilled on ice.

3.3.4.1.2 Evaporation in Snow

McMinn (1972) reports on a series of releases of North Slope crude oil (some on snow-covered sea ice) undertaken near Port Clarence, AK in January 1972. SL Ross & DF Dickins (1988) conducted mid-scale experiments to measure oil evaporation in snow on ice. Bech & Sveum (1991) report on a series of five large experiments with 1 m³ each of diesel or crude released onto or under snow on sea ice. Buist *et al.* (2008) report on experiments carried out to measure evaporation rates in snow. Oil samples were analyzed from small oil releases beneath snow during February 2005 and during March 2005 near Ottawa. The results were used to select the best mathematical algorithm to predict evaporation of oil in snow.

3.3.4.1.3 Evaporation in Pack Ice

Scott & Chatterjee (1973) report on a series of experiments to monitor oil behaviour on water, including evaporation, in ice-forming conditions. Deslaurier *et al.* (1977) report on evaporation

of No.2 heating oil spilled in pack ice in Buzzards Bay. Tebeau *et al.* (1982) present the results of a series of weathering experiments with Prudhoe Bay crude on ice conducted in Groton, CT during December and January 1980/81. SL Ross & DF Dickins (1987) conducted three 1-m³ experimental releases of crude oil in pack ice during which they measured oil evaporation over several hours. SL Ross & DF Dickins (1987b) report a series of experiments on oil evaporation from slicks on leads cut in a sheet of ice on an outdoor test tank. Wilson & Mackay (1987) report on a series of small-scale, cold-room crude oil evaporation experiments in freezing situations. Payne *et al.* (1987) report a series of extensively sampled test tank experiments conducted to quantify crude oil weathering on cold water, and in ice-forming conditions. Singaas *et al.* (1994) report on evaporation measurements taken over several days from a 10-m³ experimental crude oil spill in a marginal ice zone. Brandvik *et al.* (2010) describe a series of outdoor flume tests and subsequent field experiments to measure and model evaporation of oil spilled in pack ice.

A series of experimental spills of diesel and petrol on ice floes in the Russian Arctic (Serova, 1992; Ivanov *et al.*, 2005) showed that light distilled fuels evaporate to completion rapidly on the surface of ice floes in spring and summer, and that photo-oxidation is a more significant process in the 24-hour daylight than in more temperate climates.

Most crude oils and light products (i.e., diesel) spilled during freeze-up will remain on, or quickly migrate to, the surface of growing ice forms and undergo significant evaporation (SL Ross & DF Dickins, 1987; Payne *et al.*, 1984). Heavier, more viscous oils (bunker fuel oils and emulsified oils) could be retained in growing ice to a much greater extent and thus be less available for evaporation (Wilson & Mackay, 1987). These heavier oil forms are also much less prone to evaporation.

3.3.4.1.4 Evaporation on Melt Pools

During spring melt, encapsulated oil frozen in the ice sheet is exposed on the ice surface in a close to fresh state, at which time evaporation will begin as the oil floats on melt pools water (NORCOR, 1975; Dickins & Buist, 1981; Dickins *et al.*, 2008). Oil on melt pools tends to be herded by wind against the edge of the pool to a thickness of approximately 10-mm. This thickness of oil will evaporate more slowly than the much thinner slicks prevalent in open-water conditions, but melt pool slicks will eventually achieve approximately the same final degree of evaporation as those on open water.

3.3.4.2 Emulsification and Natural Dispersion

The formation of water-in-oil emulsions (also known as “mousse”) and the natural dispersion of oil slicks into the water column are processes driven by wave action mixing the oil slick. As such, these weathering processes are not likely to be prevalent in ice, except at an ice field’s open-water edge (SL Ross & DF Dickins, 1987; Singaas *et al.*, 1994; Sorstrom *et al.*, 2010). Wind waves (as opposed to swell) are very effectively damped by the presence of a pack ice field. Emulsification has been observed with oil in slush ice and pancakes in the laboratory when wave action is forced into the simulated ice field (Payne *et al.* 1984); it has not been observed to any great extent in field trials or actual spills, except as an ice field was dissipating and was exposed to wind-waves. Natural dispersion of oil slicks (the process of breaking waves forcing oil droplets into the water column, the smallest of which do not resurface and remain in the water) is similarly unlikely in freeze-up ice conditions. The rocking action of larger ice floes or pancakes may momentarily disperse some oil into the water around their edges, but the oil droplets created will be too large to be permanently dispersed and will rise up to either re-coalesce with the surface oil or impinge on the underside of the floe or pancake.

3.3.4.2.1 Emulsification

The mechanisms and rates of emulsification of oils spilled at sea are still poorly understood, despite being the subject of research for many decades (e.g., Berridge *et al.*, 1968). Through some mechanism, the mixing energy associated with waves causes small water droplets to become entrapped in the oil layer. Several theories have been advanced about the main chemical mechanisms involved in the process (Bobra, 1990 and 1991; Walker *et al.*, 1993; Fingas & Fieldhouse, 2011). Most experts believe that precipitates of asphaltenes and perhaps waxes and/or resins act as surface-active agents to stabilise the smaller water droplets in the forming emulsion. These natural surfactants form a “skin” around the smaller water droplets, preventing them from coalescing to form larger droplets. Without such stabilizing agents the small water droplets in the oil layer tend to combine into larger droplets that would sink through and leave the oil slick. An increase in the number of water droplets retained in the slick increases its viscosity, which in turn decreases the rate at which water droplets settle out, thus emulsification tends to occur rapidly once appropriate conditions for forming a stable emulsion are reached. In any case, emulsification inhibits natural dispersion because the process greatly increases slick viscosity. Spills of some crude oils (generally those with higher concentrations of asphaltenes) will start to form an emulsion within a few minutes of being spilled, and will form a highly viscous and stable emulsion within hours. On the other hand, some crude oils must lose some of their lighter components through evaporation before the concentrations of their asphaltenes and resins are raised to the levels required to stabilise emulsions. Most distilled petroleum products do not easily emulsify at all.

Oil spill emulsification is one of the most difficult processes to model or predict on a spill-specific basis. Except perhaps for a few oils that have been tested extensively, such as Alaska North Slope crude (ANS), it is virtually impossible to quantitatively predict when a particular crude oil will start to emulsify once spilled in a particular environment, and, once the emulsification process begins, to predict how long it will take for the spilled oil to form a “stable”, highly viscous emulsion. Nonetheless, modellers of spill behaviour have to deal with the problem of spill emulsification because it is such an important process. The usual tactic is to take advantage of a laboratory test, called the Rotating Flask Test (Zagorski & Mackay, 1982; Hokstad & Daling, 1993) that was developed to measure: (1) an oil’s tendency to form an emulsion and, (2) the stability of the emulsion once formed. The test provides some indication of oil’s emulsion forming characteristics, but does not predict rates of spill emulsification in the field. More recently, Fingas *et al.* (1998) have developed a new scheme for categorizing the type and stability of emulsions formed by oils; however, it employs complex, expensive rheological measurements in order to define an emulsion’s stability, and has thus not seen wide use as yet.

There are several references to emulsification in pack ice in the literature. Metge & Telford (1979) experimented in a small tank with crude oil behaviour in frazil ice in waves and observed emulsification of crude oil over time. Payne *et al.* (1987) report on a series of tank experiments on Prudhoe Bay crude oil fate in sea ice. At the end of the tests, the ice was allowed to warm, manually fractured to simulate break-up, and then wave action was applied to the pack ice/oil mixture. In the case of “first year” ice that had been frozen only once, the grinding action of the rotten floes and frazil and grease ice caused rapid emulsification of the oil, much faster than had been measured in open-water conditions. In the case of “multi-year” ice, which had been subjected to several freeze-thaw cycles before melting, the oil did not form water-in-oil emulsions nearly as fast nor with as high a water content, presumably because of the absence of

slush ice between the melting “multi-year” ice. The relative rates and degrees of emulsification were:

- In open water, a steady increase in water content to 50% over 6-days;
- In “first year” ice at break-up, a rapid increase to 64% in one-hour then maintaining that water content for 6-days; and
- In “multi-year” ice at break-up a slow increase to 28% over 6-days.

SL Ross & DF Dickins (1987) performed a series of 1-m³ experimental spills in dynamic pack ice off the east coast of Canada and sampled the slicks for water content. Despite the energetic conditions (3 to 4-m swell with 35 to 45 km/h winds) and the fact that the crude oil used was known to form stable emulsions at cold temperatures, no emulsification was measured. It was surmised that the presence of the ice floes damped out the spectrum of wave energy required in forming water-in-oil emulsions. Even though floes repeatedly bumped against each other in the swell, this did not cause emulsification to occur.

Hirvi *et al.* (1992) conducted a series of spill behaviour tank tests with the crude oil spilled by the *Antonio Gramsci* in the Baltic Sea in the winter of 1987. In calm conditions in pack ice, water content of the oil did not increase appreciably over a 20-day period. Once wave action was started (low frequency waves) water content began to slowly increase, reaching 28% after 34 days. A second series of tests were conducted in a separate flume, fitted with a beach and wave paddle. In these tests, pre-evaporated oil (14 days exposure) was placed among free-floating ice blocks and exposed to steeper, more energetic waves. Stable emulsions with water contents of 75% were created within hours in the beach zone of the tank where the waves were breaking.

Singsaas *et al.* (1994) report on two sets of recirculating flume trials and a 10 m³ experimental spill in the marginal ice zone of the Barents Sea, all with the same crude oil blend. In the first flume experiment in 70% ice cover water uptake was low for the first 12-hours (from 0 to 10%) in low frequency, non-breaking waves, and then increased dramatically (45% after 24-hours and 65% after 96-hours) when the wave frequency was increased and breaking waves were generated. In the second flume trial, on open water, oil rapidly emulsified to 75% in only a few hours, similar to offshore trials in open water with the same oil. In the presence of 90% ice cover with similar conditions to the previous open-water test, emulsification was significantly reduced, with maximum water contents of 40 to 50% reached after about 10-hours. In the experimental spill, ice cover was 90+% for the first few days with no wave action, and then decreased to 70% as the experimental site began to drift towards the ice edge. Wave conditions remained low throughout the seven-day sampling period. Water content of samples only began to increase after about 100-hours, reaching a maximum of 20% after 7 days. Brandvik *et al.* (2010) describes a series of outdoor flume tests and subsequent field experiments to measure and model emulsification of oil spilled in pack ice.

A series of meso-scale weathering experiments with Statfjord crude in pack ice (0%, 30%, and 90% coverage) were carried out on Svalbard in an outdoor circulating wave flume cut in the ice (Brandvik & Faskness, 2009). The results showed that weathering of spilled oil was dependent on the ice coverage and wave damping by the ice. The greater oil thicknesses in highest ice coverage reduced evaporation, and wave damping at the highest ice coverage reduced emulsification. There was a small decrease in evaporation in 30% ice cover compared with 0%, but little difference in emulsification or viscosity increase. Oil weathered in the 90% ice concentration was both ignitable and chemically dispersible at the end of the 60-hour tests;

whereas the oil weathered for the same time in the lower ice concentrations was not. Field experiments in Barents Sea to verify these results were carried out in 2008 and 2009 (Brandvik *et al.* 2010). These experiments involved several releases of fresh crude in dense pack ice (70% to 90% ice cover) and confirmed that oil emulsified much more slowly than on open water (40% water content after 6 days vs. 80% after a few hours in open water), and that the window-of-opportunity for in situ burning for these spills was greatly extended compared with open-water spills (Brandvik *et al.*, 2010a).

Quantitative tests in drift ice conditions subjected to representative wave action were used by Buist *et al.* (2008) to establish the effect of oil properties and physical environmental conditions on the initiation and rate of emulsification. The experiments involved small-scale tests in a refrigerated wind/wave tank and larger-scale tests at OHMSETT in a range of simulated drift ice concentrations with several Alaska crude oils. The results indicated that, if wave action is present in pack ice, stable water-in-oil emulsions will form with susceptible oils.

Although not truly emulsification, a related weathering process is that fluid oil slicks on ice and in freezing leads will adsorb large volumes of blowing or falling snow over time, creating a mulch-like mixture that is surprisingly dry. Once the snow content of the oil reaches a maximum of about 60 to 80% (McMinn, 1972; Nelson & Allen, 1982; SL Ross & DF Dickins, 1988) any additional snow covers the oil, hiding it from sight.

Emulsification of oil on melt pools is not expected to be significant, since most pools are far too small to allow wind waves of sufficient size to be generated. Also, water in melt pools tends to be much less saline than seawater, and this tends to destabilise water-in-oil emulsions. Rainfall may cause some emulsification of oil on melt pools, but it is likely to be unstable and temporary.

3.3.4.2.2 Natural Dispersion

Very few observations of natural dispersion of oil in pack ice have been made. Martin *et al.* (1976) and Metge & Telford (1979) both experimented in small-scale apparatus with crude oil behaviour in frazil ice in waves. They both observed that some oil droplets ended up suspended (dispersed) in the frazil ice. C-CORE (1980) noted that spilled heavy Bunker C in the pack ice off Cape Breton was progressively broken down in the slush ice between floes to smaller and smaller droplets by the grinding action of the floes. This process was observed at another Bunker C spill in the Gulf of St. Lawrence (Wilson and Mackay 1987). Payne *et al.* 1984 described a spill of JP-5 in dynamic pack ice in Cook Inlet. They conclude that no dispersion or emulsification occurred as the JP-5 evaporated rapidly. SL Ross & DF Dickins (1987) concluded that natural dispersion was negligible for three experimental crude oil spills in pack ice off Cape Breton. Hirvi *et al.* (1992) concluded that the main fate of the spilled crude in pack ice from the *Antonio Gramsci* was evaporation until the ice melted in spring and wave action began to naturally disperse remaining oil sheens. In a study of the stability of oil-in-water emulsions (commonly known as dispersions) it was shown that dispersions separated 3.5 times more slowly at near-freezing temperatures (1°C) than at 15°C (Stochmal & Gurgul, 1992). Meso-scale experiments (Singsaas *et al.* 1994) showed that natural dispersion was highest without ice, and that it decreased significantly when ice was present. In a field experiment carried out in the marginal ice zone, Sorstrom *et al.* (1994) found that water samples taken at 0.5, 1, and 3 metres depth did not show traces of the oil used in the experiment. Natural dispersion of oil on melt pools is not expected.

3.3.4.3 Other Weathering Processes

An important oil property change that may take place with oil spilled on ice in winter is the gelling of oil as it cools and evaporates, resulting from the precipitation of dissolved waxes in the oil. Oils that may be fluid in warmer temperatures can gel when the ambient temperature falls below their pour point (defined as the temperature at which sufficient waxes have precipitated from solution in the oil to prevent it from flowing under a specified force of gravity). The pour point of an oil increases as it loses light ends to evaporation. Gelled oil will be a semi-solid material that will subsequently evaporate even slower, and may develop a non-sticky, waxy surface coating.

From 2004 to 2008, a three-year experimental programme was carried out to generate empirical data and spill process algorithms in order to improve oil spill in ice behaviour models (Buist *et al.*, 2008). The research programme focused on completing a large number of small-scale experiments with four Alaskan crude oils. The emphasis was on spill processes for oil spilled on or under landfast sea ice in the Beaufort Sea. As a result of six series of small-scale experiments, the best algorithms were selected to predict:

- Equilibrium thickness of oil on quiescent cold water
- Spreading of oil on cold water
- Equilibrium oil thickness on ice
- Oil spreading on ice
- Oil spread in snow
- Stripping velocity for small oil forms under ice
- Evaporation on ice, under snow and among drift ice

In many of the small-scale experiments (primarily the spreading and evaporation test series), particularly at colder test temperatures, one or more of the crude oils had a pour point above the ambient temperature. The results of these experiments did not always correlate with the results of experiments with other, lower pour point crudes. This is because oils whose pour point exceeds ambient temperature have unusual physical characteristics. As these oils cool, wax particles begin to precipitate from solution in the bulk oil and eventually, in the absence of external mixing energy, form a polymer-like matrix in the oil that renders it a gel-like semi-solid. This has two major effects:

1. The oils develop a resistance to the initiation of flow (termed a yield stress) and become non-Newtonian fluids: typically they exhibit pseudoplastic rheology – shear thinning, and become thixotropic – their viscosity is time dependent. These changes greatly reduce, or prevent, spreading of the oil on water, on ice and through snow. At present, there is no way to mathematically model this; however, in most situations gelled oil simply does not spread at all.
2. The onset of the internal wax matrix greatly restricts diffusive movement of the volatile molecules through the slick to the air/oil surface and changes the way in which the oil evaporates. This reduced evaporation can be effectively modeled by using an internal resistance to mass transfer.

Dissolution of water-soluble components of the oil in freeze-up ice forms will occur; as it does any time oil is in contact with water. It will likely account for the removal of only approximately 1% of the volume of the oil (Payne *et al.*, 1984). Another series of experiments on Svalbard involved studying the dissolution over four months of water-soluble components from six

different crude oils encapsulated near the surface in sea ice from February to June (Faskness & Brandvik, 2005). It was concluded that the water-soluble components would diffuse down through the ice sheet to the bottom of the sheet (110-cm thick), but that concentrations at the bottom would be low (6 ppb). In field experiments in pack ice (Brandvik *et al.*, 2009) no significant water-soluble fractions were measured in the water beside a six-day experimental spill.

Oil spilled under near shore ice will be encapsulated by growing ice. If the oil is exposed early enough in the spring melt to be transported by river over flooding, it will have the opportunity to spread to thin slicks and evaporate faster. As well, when river water drains through cracks and holes in the sheet, it may draw some oil with it (Dickins & Owens, 2002). This oil will be dispersed into the water column beneath the ice sheet. Larger oil drops will rise up to contact the bottom of the ice surface in the vicinity of the drain point, from whence they will ultimately appear again on the ice surface as the melt progresses. Smaller droplets may be carried some distance from the drain point, but will most likely also rise to the under-side of the ice sheet. It is unlikely that sufficient turbulence exists in the water beneath the ice sheet to maintain any but the very smallest oil droplets in suspension.

When an ice sheet deteriorates and breaks up, oil remaining in melt pools will be discharged onto water between the floes in the form of thin sheens trailing from the drifting, rotting ice (Dickins & Buist, 1981). Gelled oil could be discharged as thicker, non-spreading mats or droplets. Once exposed to significant wave action, fluid oil will begin to emulsify and naturally disperse. Since gelled oil forms are particularly resistant to emulsification and natural dispersion, these will survive much longer than slicks of fluid oil.

Oil spilled directly into pack ice conditions in spring will weather much as it does in open-water conditions. Oil released under drifting floes will quickly surface through the porous ice and begin to evaporate. The floes themselves are rapidly deteriorating under the influence of wind and waves, and will soon release the oil as they candle and rot. The absence of large amounts of brash and slush ice between will permit the slicks to spread and evaporate more quickly than during freeze-up. Warmer spring temperatures will also accelerate evaporation. Once waves begin to act on the slicks, emulsification and natural dispersion will begin.

Wind and/or currents will herd oil spilled in leads to a downwind edge where it will accumulate with the frazil ice (SL Ross and DF Dickins, 1987b). Small amounts of oil may be incorporated into the frazil ice (this is only likely for heavy, viscous oils such as bunker fuels - Wilson & Mackay, 1987); most crude oils will remain on the surface of the consolidating frazil ice, eventually sitting on top of the refrozen ice sheet. This oil would be ultimately be covered by snow.

References to Chapter 3

- Allen, A. and W. Nelson. 1981. **Oil Spill Countermeasures in Landfast Sea Ice**. In: *Proceedings of the 1981 Oil Spill Conference*. API, Washington, DC, U.S.
- Barnes, P.W., E. Reimnitz, L.J. Toimil, and H.R. Hill. 1979. **Fast-ice thickness and snow depth in relation to oil entrapment potential, Prudhoe Bay, Alaska**. In: *Proceedings of the Fifth Ports and Ocean Engineering under Arctic Conditions Conference*, Trondheim, Norway, 2:1205-1225.
- Bech, C. and P. Sveum. 1991. **Spreading of oil in snow**. In: *Proceedings of the Sixth Arctic Marine Oilspill Program (AMOP) Technical Seminar*. Environment Canada. Ottawa, ON. pp. 57-71.

- Belaskas, D.P. and P.D. Yapa. 1991. **Oil spreading in broken ice**. Technical Report 91-6, Department of Civ. and Env. Engineering, Clarkson University, Potsdam, NY.
- Belore, R.C., J. McHale and T. Chapple. 1998. **Oil Deposition Modelling for Surface Oil Well Blowouts**. In: *Proceedings of the Arctic and Marine Oilspill Program (AMOP) Technical Seminar*, No. 21, Vol. 1. Environment Canada, Ottawa, ON, Canada.
- Berger, D. and D. Mackay. 1994. **The Evaporation of Viscous or Waxy Oils – When is a Liquid Phase Resistance Significant?** In: *Proceedings of the Seventeenth Arctic and Marine Oilspill Program (AMOP) Technical Seminar*. Environment Canada, Ottawa, ON, Canada. pp. 77-92.
- Berridge, S., M. Thew and A. Loriston-Clarke. 1968. **The Formation and Stability of Emulsions of Water in Crude Petroleum and Similar Stocks**. *Journal of the Institute of Petroleum*, Vol. 54, pp. 333-357.
- Bobra, M. 1990. A Study of the formation of water-in-oil emulsions. Proceedings of the Thirteenth Arctic and Marine Oilspill Program Technical Seminar, June 6-8, Edmonton, Alberta. Environment Canada, Ottawa, ON, Canada. pp. 87-117.
- Bobra, M. 1991. **Water-in-oil Emulsification: A Physicochemical Study**. In: *Proceedings of the 1991 International Oil Spill Conference*, March 4-7, San Diego, CA. American Petroleum Institute, Washington, DC, U.S., pp. 483-488.
- Bobra, A.M. and M.F. Fingas. 1986. **The Behaviour and Fate of Arctic Oil Spills**. *Water Science Technology*, 18(2):13-23.
- Brandvik, P.J., I. Singsaas, and P.S. Daling. 2004. **Oil Spill R&D in Norwegian Arctic Waters with Special Focus on Large-scale Oil Weathering Experiments**. Paper presented at the *Inter Spill Conference*, Trondheim, Norway.
- Brandvik, P. and L-G. Faskness. 2009. **Weathering Processes in Arctic Oil Spills: Meso-Scale Experiments with Different Ice Conditions**. *Cold Regions Science and Technology* 55 (2009), 160-166.
- Brandvik, P.J., Resby, J.L.M., Daling, P.S., Leirvik, F., and J. Fritt-Rasmussen. 2010. Meso-scale weathering of oil as a function of ice conditions. Oil properties, dispersability and in situ burnability of weathered oil as a function of time. SINTEF Materials and Chemistry, Marine Environmental Technology report no. 15563.
- Brandvik, P.J., J. Fritt-Rasmussen, R. Daniloff, and F. Leirvik. 2010a. **Using a Small Scale Laboratory Burning Cell to Measure Ignitability for In Situ Burning of Oil Spills as a Function of Weathering**. In: *Proceedings of the 33rd Arctic Marine Oil Spill Programme (AMOP) Technical Seminar*, Environment Canada on Environment Contamination and Response, Vol. 2, pp. 755–773.
- Buist, I.A., S.G. Potter, and D.F. Dickins. 1983. **Fate and Behaviour of Water-in-Oil-Emulsions in Ice**. In: *Proceedings of the Sixth Arctic Marine Oilspill Program (AMOP) Technical Seminar*. Environment Canada. Ottawa, ON.
- Buist, I.A., S.L. Ross, B.K. Trudel, E. Taylor, T.G. Campbell, P.A. Westphal, M.R. Meyers, G.S. Ronzio, A.A. Allen, and A.B. Nordvik. 1994. **The science, technology, and effects of controlled burning of oil spills at sea**. MSRC Technical Report Series 94-013. Marine Spill Response Corporation, Washington, DC, U.S.
- Buist, I., R. Belore, D.F. Dickins, A. Guarino, D. Hackenberg, and Z. Wang. 2008. **Empirical Weathering Properties of Oil in Ice and Snow**. In: *Proceedings of the Northern Oil and Gas Research Forum*. MMS Alaska. Anchorage. AK, U.S.
- Cammaert, G. 1980. *Oil and gas under ice laboratory study*. Acres Consulting report to Canadian Marine Drilling Ltd and Environment Canada, Ottawa, ON, Canada.
- C-CORE. 1980. **An oilspill in pack ice**. Environment Canada Report EE 15, Ottawa, ON, Canada.
- Chen, E.C. 1972. **Arctic Winter Oil Spill Test**. Report to Dept. of the Environment, Inland Waters Directorate, Ottawa, ON.
- Chen, E.C., J.C.K. Overall, and C.R. Phillips. 1974. **Spreading of crude oil on an ice surface**. *Can. J. Chem. Eng.*, February 1974.

- Chen, E., B. Keevil, and R. Ramsier .1976. **Behaviour of Crude Oil Under Fresh Water Ice.** *Journal of Canadian Petroleum Technology*, Vol. 15, pp. 79-83.
- Comfort. G. 1986. **Analytical modelling of oil and gas spreading under ice.** Environmental Studies Research Funds Report No. 077. Ottawa, ON.
- Comfort, G. and W. Purves. 1982. **The behaviour of crude oil spilled under multiyear ice.** Environment Canada Report EPS-4 EC 82 4. Ottawa, ON.
- Cox, J.C. and L.A. Schultz. 1980. **The Transport and Behaviour of Oil Spilled Under Ice.** In: *Proceedings of the Third Arctic Marine Oilspill Program (AMOP) Technical Seminar*, Environment Canada, Ottawa, ON, Canada. pp. 45-61.
- Cox, J.C. and L.A. Schultz. 1981. **The Containment of Oil Spilled Under Rough Ice.** In: *Proceedings of the 1981 International Oil Spill Conference (IOSC)*. American Petroleum Institute, Washington, DC, U.S., pp. 45-61.
- Deslaurier, P.C., S. Martin, B. Morson, and B. Baxter. 1977. **The physical and chemical behaviour of the Bouchard No. 65 oil spill in the ice covered waters of Buzzards Bay.** NOAA OCSEAP Report. Boulder, CO, U.S.
- Dickins, D.F., A. Dickinson, and B. Humphrey. 1986. **Pack Ice in Canadian Waters: Dimensions and Dynamics of Leads and Floes.** Environment Canada Report EE-82. Ottawa, ON.
- Dickins, D.F. and I. Buist. 1981. **Oil and Gas Under Sea Ice.** Prepared by Dome Petroleum Ltd. for COOSRA, Report CV-1, Volumes I and II.
- Dickins, D. and N. Glover. 1996. **Oil and ice: Beaufort Sea nearshore oil spill response options.** Presented at the *Symposium on Oil Spill Prevention and Readiness*, Valdez, AK.
- Dickins, D.F. and I. Buist. 1999. **Countermeasures for Ice Covered Waters.** *Pure and Applied Chemistry*, 71(1), London, UK.
- Dickins, D.F. and E. Owens. 2002. **Annual Ice Cycle at the Mouth of the Colville River and Implications for Oil Transport.** In: *Proceedings of the 25th Arctic and Marine Oilspill Program (AMOP) Technical Seminar*, Environment Canada, Ottawa, ON, Canada, pp. 1169-1190.
- Dickins, D.F., L. Liberty, W. Hirst, J. Bradford, V. Jones, L. Zabilansky, G. Gibson, and J. Lane. 2005. **New and Innovative Equipment and Technologies for the Remote Sensing and Surveillance of Oil in and Under Ice.** In: *Proceedings of the 28th Arctic and Marine Oilspill Program (AMOP) Technical Seminar*, Calgary, AB, June 2005. (MMS Contract 1435-01-04-36285). Environment Canada, Ottawa, ON, Canada.
- Dickins, D.F., P.J. Brandvik, J. Bradford, L-G. Faksness, L. Liberty, L. and R. Daniloff. 2008. **Svalbard 2006 Experimental Oil Spill Under Ice: Remote Sensing, Oil Weathering Under Arctic Conditions and Assessment of Oil Removal by In-situ Burning.** In: *Proceedings of the 2008 International Oil Spill Conference (IOSC)*, Savannah, GA. American Petroleum Institute, Washington, DC, U.S.
- D F Dickins Associates Ltd. and Fleet Technology Limited. 1992. **Behaviour of Spilled oil at Sea (BOSS): Oil-in-Ice Fate and Behaviour.** Report submitted to Environment Canada, U.S. Minerals Management Service.
- El-Tahan, H. and S. Venkatesh. 1994. **Behaviour of Oil Spills in Cold and Ice-Infested Waters – Analysis of Experimental Data on Oil Spreading.** In: *Proceedings of the Arctic and Marine Oilspill Program (AMOP) Technical Seminar No. 17*, Vol. 1, pp. 337-354. Environment Canada, Ottawa, ON, Canada.
- Faskness, L-G. and P. Brandvik. 2005. **Dissolution of Water Soluble Components from Oil Spills Encapsulated in Ice.** In: *Proceedings of the Arctic and Marine Oilspill Program (AMOP) Technical Seminar*, No. 28, Vol. 1, pp. 59-73. Environment Canada, Ottawa, ON, Canada.
- Fay, J.A. 1969. **The spread of oil slicks on a calm sea.** Fluid Mechanics Laboratory, Department of Mechanical Engineering, Massachusetts Institute of Technology, Cambridge, MA.
- Fay, J.A. and D.P. Hoult. 1971. **Physical Processes in the Spread of Oil on a Water Surface.** Massachusetts Institute of Technology (MIT), Cambridge, MA. - NTIS report #AD726281.
- Fazal, R. and J. Milgram. 1979. **The Effects of Surface Phenomena on the Spreading of Oil on Water.** Massachusetts Institute of Technology (MIT) Report MITSG-79-31. Cambridge, MA.

- Fingas, M. 1994. **The Evaporation of Oil Spills**. In: *Proceedings of the Eighteenth Arctic and Marine Oilspill Program (AMOP) Technical Seminar*. Environment Canada, Ottawa, ON, Canada, pp. 43-60.
- Fingas, M., B. Fieldhouse, and J. Mullin. 1998. **Studies of Water-in-Oil Emulsions: Stability and Oil Properties**. In: *Proceedings of the 21st Arctic and Marine Oilspill Program (AMOP) Technical Seminar*. Environment Canada, Ottawa, ON, Canada, pp. 1-26.
- Fingas, M. and B. Fieldhouse. 2011. **Water-in-oil Emulsions: Formation and Prediction**. In: *Proceedings of the Thirty-fourth Arctic and Marine Oilspill Program (AMOP) Technical Seminar on Environmental Contamination and Response*. Environment Canada, Ottawa, ON, Canada.
- Free, A.P., J.C. Cox, and L.A. Schultz. 1982. **Laboratory studies of oil spill behaviour in broken ice fields**. In: *Proceedings of the 5th Annual Arctic Marine Oilspill Program (AMOP) Technical Seminar*, Edmonton. AB. Environment Canada, Ottawa, ON, Canada.
- Glaeser, J.L. and G.P. Vance. 1971. **A study of the behaviour of oil spills in the Arctic**. USCG. Report CG-D-53-74. Washington, DC, U.S.
- Goodman, R.H., A.G. Holoboff, T.W. Daley, P. Waddell, L.D. Murdock, and M. Fingas. 1987. **A technique for the measurement of underice roughness to determine oil storage volumes**. In: *Proceedings of the 1987 International Oil Spill Conference (IOSC)*. American Petroleum Institute, Washington, DC, U.S., pp. 395–398.
- Gjosteen, J. and S. Loset. 2004. **Laboratory Experiments on Oil Spreading in Broken Ice**. *Cold Regions Science and Technology*, 38 (2004):103-116.
- Hirvi, J-P., J. Koponen, and H. Vepsa. 1992. **A Case Study of the M/T Antonio Gramsci Accident in Ice-Infested Waters**. In: *Combating Marine Oil Spills in Ice and Cold Climates, HELLCOM Seminar*, Helsinki, Finland.
- Hokstad, J. and P. Daling. 1993. **Methodology for Testing Water-in-Oil Emulsions and Demulsifiers. Description of Laboratory Procedures**. In: *Formation and Breaking of Water-in-Oil Emulsions: Workshop Proceedings Marine Spill Response Corporation (MSRC)*, MSRC Technical Report Series 93-108, Washington DC, U.S., pp. 239-254.
- Hollebone, B.P., M. Fingas, D.N.S. Permann, and J. Mullin. 1998. **The fate and behaviour of oil in freezing environments: Manuscripts review draft report**. Environment Canada. Ottawa, ON, Canada.
- Hoult, D.P., S. Wolfe, S. O’Dea, and J.P. Patureau. 1975. **Oil in the arctic**. Technical Report CG-D-96-75, Prepared for Dept. of Transportation, U.S. Coast Guard, Washington, DC, U.S.
- Ivanov, B., A. Bezgreshnov, N. Kubyskin, and A. Kursheva. 2005. **Spreading of Oil Products in Sea Ice and Their Influence on the Radiation Properties of the Snow-Ice Cover**. In: *Proceedings of the 18th International Port and Oceans Engineering Under Arctic Conditions*. Vol 2, pp. 853-862.
- Jensen, H. 1994. **1993 Norwegian Experimental Spill**. In: *Proceedings of the Conference on Oil Spill Response in Broken Ice*. DF Dickins Assoc., La Jolla, CA, U.S.
- Jordan, RE. and J.R Payne. 1980. **Fate and weathering of petroleum spills in the marine environment**. Ann Arbor Science Pub, Ann Arbor, MN, U.S.
- Kawamura, P., D. Mackay, and M. Goral. 1986. **Spreading of Chemicals on Ice and Snow**. Report to Environment Canada, EETD, Ottawa, ON, Canada.
- Keevil, B.E. and R. Ramseier. 1975. **Behaviour of Oil Spilled under Floating Ice**. In: *Proceedings of the 1975 Conference on Prevention and Control of Oil Pollution*. American Petroleum Institute, Washington, DC, U.S., pp. 497–501.
- Kisil, C.A. 1981. **A Study of Oil and Gas in Fresh and Salt Water-Ice Systems**. University of Toronto, ON, MSc. Thesis.
- Kovacs, A. 1977. **Sea Ice Thickness Profiling and Under-Ice Oil En-Trapment**. In: *Offshore Technology Conference*, Houston, TX. Paper No. 2949.
- Kovacs, A., R.M. Morey, D.F. Cundy, and G. Decoff. 1981. **Pooling of Oil under Sea Ice**. In: *Proceedings, POAC 81: Sixth International Conference on Port and Ocean Engineering under Arctic Conditions*, Quebec, QC, pp. 912-922.

- Lampela, K. 2007. **Baltic Approach to Oil Spill Recovery in Ice: Case Studies and Recent Development in Baltic Sea states.** In: *Proceedings of the 2007 International Oil & Ice Workshop*. Minerals Management Service.
- Mackay, D. 1984. **The Fate and Behaviour of Oil in Cold Climates.** Department of Chemical Engineering and Applied Chemistry. Report to Environment Canada, Ottawa, ON, Canada.
- Mackay, D., P.J. Leinonen, J.C.K. Overall, and B.R. Wood. 1975. **The Behaviour of Crude Oil in Snow.** *Arctic*, 28(1):9-22.
- MacNeill, M. and R. Goodman. 1985. **Motion of Oil in Leads.** In: *Proceedings of the Eighth Arctic Marine Oilspill Program (AMOP) Technical Seminar*, Environment Canada, Ottawa, ON, Canada, pp. 131-142.
- Malcolm, J. and A. Cammaert. 1981. **Movement of Oil and Gas Spills Under Sea Ice.** In: *Proceedings of the Sixth International Conference on Port and Ocean Engineering Under Arctic Conditions (POAC)*, pp. 923-936.
- Martin, S., P. Kauffman, and P. Welander. 1976. **A Laboratory Study of the Dispersion of Crude Oil within Sea Ice Grown in a Wave Field.** In: *Proceedings of the 27th Alaska Science Conference*, 2:261-787. Fairbanks, AK, U.S.
- Martin, S. 1979. **Field Study of Brine Drainage and Oil Entrainment in First-Year Sea Ice.** *Journal of Glaciology*, 22(88):473-501.
- McMinn, J. 1972. **Crude Oil Behaviour on Arctic Winter Ice: Final Report.** Office of R&D, U.S. Coast Guard, Project No. 734108. NTIS Publ. No. AT-754. Washington, DC, U.S.
- Metge, M. and A.S. Telford. 1979. **Oil in Moving Pack Ice - Laboratory Study.** *Proceedings of the Fifth International Conference on Port and Ocean Engineering Under Arctic Conditions (POAC)*, Trondheim, Norway, pp. 255-264.
- Milne, A., R. Herlinveaux, and G. Wilton. 1977. **A Field Study on Permeability of Multiyear Ice to Seawater and Implications of its Permeability to Oil.** Fisheries and Environment Canada, EPS Technical Development Report, EPS-4-EC-77-11, Ottawa, ON, Canada.
- Moir, J. and Y. Lau. 1975. **Some Observations of Oil Slick Containment by Simulated Ridge Keels.** Environment Canada, Burlington, ON, Canada.
- National Research Council (NRC). 1985. **Oil in the Sea: Impacts, Fate and Effects.** National Academy Press, Washington, DC, U.S., 601 p.
- Nelson, W.G. and A.A. Allen. 1982. **The Physical Interaction and Cleanup of Crude Oil with Slush and Solid First Year Ice.** In: *Proceedings of the Fifth Arctic Marine Oil Spill Program (AMOP) Technical Seminar*, Environment Canada, Ottawa, ON, Canada, pp. 37-59.
- Nerella, V.R. and E.C. Jarvis. 1980. **A Manual Technique for Predicting Offshore Oil Spill Movement.** Report to Atmospheric Environment Service, Downsview, ON.
- NORCOR Engineering and Research Ltd. 1975. **The Interaction of Crude Oil with Arctic Sea Ice.** Prepared for the Beaufort Sea Project, Department of the Environment, Victoria, BC, Beaufort Sea Technical Report No. 27.
- NORCOR Engineering and Research Ltd. 1977. **Probable Behaviour and fate of a Winter Oil Spill in the Beaufort Sea.** EPS Report, Environment Canada, Ottawa, ON, Canada.
- Ohtsuka, N., K. Ohshima, K. Maida, N. Usami, and H. Saeki. 1999. **Weathering of Oil Spills in Icy Seawater and Characteristics of Crude Oil Which Trapped into Ice Floe.** In: *Proceedings of the 15th International Port and Oceans Engineering Under Arctic Conditions (POAC)*, Expoo, Finland, Vol. 2, pp. 828-837.
- Ohtsuka N., K. Ogiwara, S. Takahashi, K. Maida, Y. Watanabe, and H. Saeki . 2001. **Experimental Study on Spreading of Oil Under Ice Floes.** In: *Proceedings of the 16th International Port and Oceans Engineering Under Arctic Conditions (POAC)*, Ottawa, ON, Canada, 3:1333-1342.
- Payne, J.R., B.E. Kirstein, G.D. McNabb, Jr., J.L. Lambach, R. Redding, R.E. Jordan, W. Hom, C. de Oliveira, G.S. Smith, D.M. Baxter, and R. Geagel. 1984: **Multivariate Analysis of Petroleum Weathering in the Marine Environment - Subarctic.** Vol. 1 & 11. In: *Environmental Assessment of the Alaskan Continental Shelf*, final reports of principal investigators. U.S. Department of Commerce - NOAA. OCSEAP Final Rep. 21 & 22 (1984). 690 pp.

- Payne, J.R., G. McNabb, L. Hachmeister, B. Kirsten, J. Clayton, C. Phillips, R. Redding, C. Clary, G. Smith, and G. Farmer. 1987. **Development of a Predictive Model for the Weathering of Oil in the Presence of Sea Ice**. Outer Continental Shelf Environmental Assessment Program, Final Reports of Principal Investigators. Vol 59, NOAA/OCSEAP, Washington, DC, U.S., pp. 147-461.
- Purves, F. 1978. **The Interaction Of Crude Oil And Natural Gas With Laboratory Grown Saline Ice**. Prepared by ARCTEC Canada for Environment Canada, EPS-4-EC-78-9, Ottawa, ON, Canada.
- Puskas, J. and E. McBean. 1986. **The Transport of Crude Oil Under Saline Ice**. In: *Proceedings of the Fourth International Conference on Cold Region Engineering*. ASCE, NY, NY, pp. 670-684.
- Puskas, J., E. McBean, and N. Kouwen. 1987. **Behaviour and Transport of Oil Under Smooth Ice**. *Canadian Journal of Civil Engineering*, Vol 14, pp. 510-518.
- Reed, M. and O.M. Aamo. 1994. **Real Time Spill Forecasting During MIZ'93**. In: *Proceedings of the Arctic and Marine Oilspill Program (AMOP) Technical Seminar*, 17(2):785-797. Environment Canada, Ottawa, ON, Canada.
- Rosenegger, L.W. 1975. **The Movement of Oil Under Sea Ice**. Prepared by Imperial Oil Limited for the Beaufort Sea Project; Beaufort Sea Technical Report No. 28. Department of the Environment Canada, Victoria, BC, Canada.
- Rytkonen, J., S. Liukkonen, and T. Riipi. 1998. **Laboratory Tests of Oil Spreading under the Ice Cover**. In: *Proceedings of the International Conference on Oil and Hydrocarbon Spills: Modelling, Analysis and Control*. Southampton, UK, pp. 155-164.
- Sayed, M. and S. Loset. 1993. **Laboratory Experiments of Oil Spreading in Brash Ice**. In: *Proceedings of the 3rd International Offshore and Polar Engineering Conference*, Vol 1, pp. 224-231.
- Sayed, M. and S. Ng. 1993. **Crude Oil Spreading in Brash Ice – Data Report**. PERD Report No. 6B3017. Ottawa, ON, Canada.
- Serova, I. 1992. **Behaviour of Oil in Ice and Water at Low Temperatures**. In: *Proceedings of Combatting Marine Oil Spills in Ice and Cold Climates, HELLCOM Seminar*, Helsinki, Finland.
- Scott, B.F. and R.M. Chatterjee. 1973. **Behaviour of Oil under Canadian Climate Conditions. Part 1 - Oil on Water under Ice-Forming Conditions**. Scientific Series No. 50, Environment Canada, Ottawa, ON, Canada.
- Singsaas, I., P.J. Brandvik, P.S. Daling, M. Reed, and A. Lewis. 1994. **Fate and Behaviour of Oils Spilled in the Presence of Ice - A Comparison of the Results from Recent Laboratory, Meso-Scale and Field Tests**. In: *Proceedings of the 17th Arctic and Marine Oilspill Program (AMOP) Technical Seminar*, Environment Canada, Ottawa, ON, Canada, pp. 355-370.
- S.L. Ross Environmental Research Limited (SL Ross) and DF Dickins Associates Ltd. (DF Dickins). 1987. **Field Research Spills to Investigate the Physical and Chemical Fate of Oil in Pack Ice**. Environmental Studies Revolving Funds, Report No. 062, Ottawa, ON, Canada.
- S.L. Ross Environmental Research Limited (SL Ross) and D.F. Dickins Associates Limited. (DF Dickins). 1987b. **Oil Spills in Leads: Tank Tests and Modelling**. Report to Environment Canada, EETD, Ottawa, ON, Canada.
- S.L. Ross Environmental Research Limited (SL Ross) and Energetex Engineering. 1986. **In Situ Burning of Uncontained Oil Slicks**. Environmental Emergencies Technology Division, Environmental Protection Service, Environment Canada, EE-60, Ottawa, ON, Canada.
- S.L. Ross Environmental Research Limited (SL Ross) and DF Dickins Associates Ltd. (DF Dickins). 1988. **Modelling of Oil Spills in Snow**. Environment Canada Report EE-109, Ottawa, ON, Canada.
- S.L. Ross Environmental Research Limited (SL Ross) and D. Mackay Environmental Research Limited. 1988. **Laboratory Studies of the Behaviour and Fate of Waxy Crude Oil Spills**. Environmental Studies Research Funds, Report 084, Ottawa, ON, Canada.
- S.L. Ross Environmental Research Limited (SL Ross). 2003. **Laboratory Analysis of the Spill-Related Properties of Chayvo Crude Oil on Cold Water and Broken Ice**. Report to ExxonMobil Upstream Research, Houston, TX, U.S.

- SL Ross Environmental Research Ltd. (SL Ross), DF Dickins Associates LLC (DF Dickins), Envision Planning Solutions Inc. 2010. **Beaufort Sea Oil Spills State of Knowledge Review and Identification of Key Issues**. Environmental Studies Research Funds Report No. 177. Calgary, AB, Canada. 126p.
- Sørstrøm, S.E., Ø. Johansen, S. Vefsnmo, S.M. Løvås, B.O. Johannessen, S. Løset, P. Sveum, C. Guénette, P.J. Brandvik, I. Singaas, and H. Jensen. 1994: **Experimental Oil Spill in the Marginal Ice Zone**. April 1993 (MIZ-93). Final Report. IKU, Trondheim (in Norwegian).
- Sørstrøm, S.E., P.J. Brandvik, I. Buist, P. Daling, D.F. Dickins, L-G. Faksness, S. Potter, J. Fritt-Rasmussen, and I. Singaas. 2010. **Joint Industry Program on Oil Spill Contingency for Arctic and Ice Covered Waters: Summary Report**. SINTEF Materials and Chemistry, Marine Environmental Technology Report No. A14181.
- Stiver, W. and D. Mackay. 1983. **Evaporation Rate of Spills of Hydrocarbons and Petroleum Mixtures**. Environmental Protection Service, Environment Canada, Report EE-8. Ottawa, ON, Canada.
- Stochmal, W. and H. Gurgul. 1992. **The Crude Oil-Water Emulsion in the Polar Conditions**. In: *Combatting Marine Oil Spills in Ice and Cold Climates HELLCOM Seminar*, Helsinki, Finland.
- Tebeau, P.A., T.M. Meehan, and J.C. Myers. 1982. **A Laboratory Experiment on Oil Weathering under Arctic Conditions**. U.S. Coast Guard Report CG-D-34-82. Washington, DC, U.S.
- Tebeau, P.A., T.M. Meehan, and S.A. Saspoff. 1984. **A Laboratory Study of Oil Spreading under Arctic Conditions**. United States Coast Guard R&D Centre. Groton, CT, U.S.
- Tekmarine. 1984. **1984 Beaufort Sea Multi-Year Ice Floe Tracking Study**. Alaska Oil and Gas Association Project, No. 280. Sohio Petroleum Company, Anchorage, AK, U.S.
- Timco, G. and M. Davies. 1995. **Laboratory Tests of Oil Fate in Cold Water, Ice and Waves**. National Research Council of Canada Report HYD-TR-002. Ottawa, ON, Canada.
- Tsang, G. and E. Chen. 1978. **Laboratory Study of Diversion of Oil Spilled under Ice Cover**. Environment Canada, Burlington, ON.
- Uzuner, M., F. Weiskopf, J. Cox, and L. Schultz. 1979. **Transport of Oil under Smooth Ice**. U.S. EPA Report EPA-600/3-79-041. Corvallis Environmental Research Laboratory, Office of Research and Development, U.S. EPA, Corvallis, OR, U.S.
- Vefsnmo, S. and B.O. Johannessen. 1994. **Experimental Oil Spill in the Barents Sea - Drift and Spread of Oil in Broken Ice**. In: *Proceedings 17th Arctic and Marine Oil Spill Program (AMOP) Technical Seminar*, Vancouver, BC. Environment Canada, Ottawa, ON, Canada.
- Venkatesh, S., H. El-Tahan, G. Comfort, and R. Abdelnour. 1990. **Modelling the Behaviour of Oil Spills in Ice-Infested Waters**. *Atmosphere-Ocean*, 28(3):303-329, Canadian Meteorological and Oceanographic Society.
- Walker, A.H., D.L. Ducey, J.A. Gould, and A. Nordvik. 1993. **Formation and Breaking of water-in-oil Emulsions: Workshop Proceedings**. MSRC Technical Report Series 93-018: Marine Spill Response Corporation, Washington, DC, U.S.
- Weerasuriya, S and P. Yapa. 1993. **Unidirectional Spreading of Oil under Ice**. *Can. J. Civ. Eng.*, Vol. 20, pp. 50-56.
- Wilkinson J.P., B. Wadhams, and N.E. Hughes. 2007. **A New Technique to Determine the Spread of Oil Spill under Fast Ice**. In: *Proceedings of the 19th International Port and Oceans Engineering Under Arctic Conditions (POAC)*, Dalian, China, Vol. 2, pp. 855-867.
- Wilson, D.G. and D. Mackay. 1987. **The Behaviour of Oil in Freezing Situations**. Prepared at the University of Toronto for the Environmental Protection Directorate, Environment Canada, Report No. EE-92, Ottawa, ON, Canada.
- Wolfe, L.S. and D.P. Hoult. 1974. **Effects of Oil under Sea Ice**. *Journal of Glaciology*, Vol. 13, p. 473-488.
- Wotherspoon, P., J. Swiss, and R. Kowalchuck. 1985. **Oil in Ice Computer Model**. Environmental Studies Research Funds report 019. National Energy Board. Calgary, AB, Canada.
- Yapa, P.D. and D. Belaskas. 1993. **Radial Spreading of Oil Under and Over Broken Ice: An Experimental Study**. *Can. J. Civ. Eng.*, Vol. 20, pp. 910-922.

- Yapa, P.D. and S.A. Weerasuriya. 1997. **Spreading of Oil Spilled Under Floating Broken Ice.** *Journal of Hydraulic Engineering*, 123(8):69-71, August 1977.
- Zagorski, W. and D. Mackay. 1982. **Water in Oil Emulsions: a Stability Hypothesis.** In: *Proceedings of the 5th Arctic and Marine Oilspill Program (AMOP) Technical Seminar*, Environment Canada, Ottawa, ON, Canada, pp. 61-74.

CHAPTER 4. THE SCIENCE OF IN SITU BURNING

4.1 Steady-State Burning Fundamentals

In order to burn oil spilled on water or ice three elements must be present: fuel, oxygen and a source of ignition. In order to supply the fuel for combustion, oil must be heated to a temperature, called the Fire Point. The Fire Point is the temperature, a few degrees above the Flash Point, at which the oil is warm enough to supply vapours at a rate sufficient to support continuous burning. Combustion is a vapour-phase phenomenon. The key oil slick parameter that defines whether or not the oil will burn is slick thickness; if the oil is thick enough it acts as insulation and keeps the burning slick surface at a high temperature by reducing heat loss to the underlying water. As the slick thins, increasingly more heat passes through it; eventually enough heat is transferred through the slick to allow the oil temperature to drop below its fire point, at which time burning stops.

Figure 4-1 illustrates the heat and mass transfer processes that occur during the in situ burning of an oil slick on water. The key driving process is radiative heat transfer from the flame back to the surface of the slick. This heat is partially used by vaporizing the liquid hydrocarbons which rise to mix with air above the slick and oxidise - or burn; the remainder transfers through the slick to the underlying water. Once ignited, a burning thick oil slick reaches a quasi-steady-state in which the vaporization rate sustains the necessary heat transfer back to the slick surface.

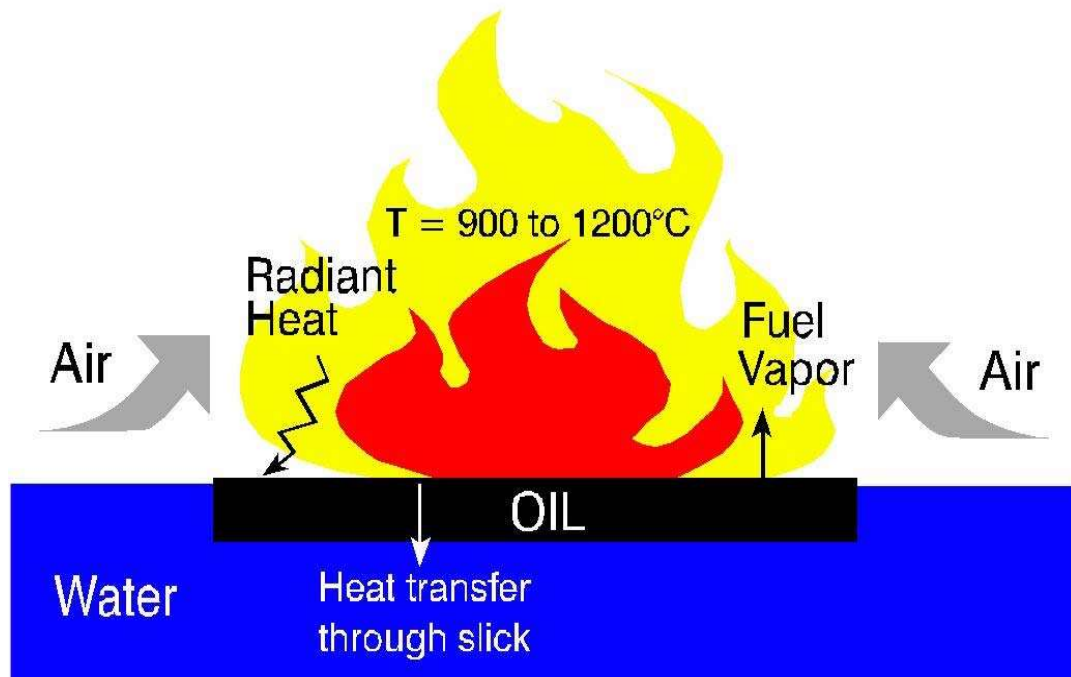

Figure 4-1 Key heat and mass transfer processes for in situ burning. (Source: SL Ross Environmental Research)

Maximum temperatures in the flame region of 900°C to 1200°C for crude oil burns on still water have been measured using thermocouples by a number of researchers (Hagglund & Persson 1976; Evans *et al.*, 1987; McAllister & Buist, 1981; SINTEF & SL Ross, 1993; and Koseki, 1993). Koseki (1993) reports thermocouple readings of $1,200^\circ$ to $1,400^\circ\text{C}$ in a 17-m diameter

fire. Just before the fire extinguishes, boiling water beneath the slick ejects oil droplets into the flame creating more intense burning; during this vigorous burning phase flame temperatures may jump by 150°C to 200°C (Evans et al., 1987; SINTEF & SL Ross, 1993). Wind can also increase flame temperatures due to improved fuel/air mixing (Babrauskas, 1988).

Several authors have studied the heat transfer processes that occur during in situ burning and pool burning (pool burning refers to combustion of oil in pans or open-topped tanks with no water substrate). In 1981 Twardus & Brzustowski proposed a model in which the rate of combustion is controlled by radiative heat transfer to the fuel surface, the heats of vaporization and combustion of the subject oil, and heat conduction through the slick to the underlying water. The model shows the correct relationships and allows for the incorporation of wind speed into the heat transfer model. This model was modified (Brzustowski & Twardus, 1982) to incorporate a radiative heat loss component through the slick.

Researchers at Battelle (Battelle, 1979) conducted an in-depth review of in situ combustion processes and, starting from the basic combustion model described above (Energetex, 1978), performed an extensive review of pool fire heat transfer. Their premise was that for quasi-steady-state burning to proceed, the fraction of heat radiated back to the fire must be greater than the sum of the heat of vaporization of the oil and the sensible heat required to warm the oil from ambient temperature to its boiling point. The key parameter to be determined was the fraction of the heat of combustion of the fuel transferred back to the fuel surface. There are three mechanisms by which heat can be transferred: conduction, convection and radiation. In turbulent fires conduction can be ignored, leaving the latter two. The Battelle study concluded that radiative heat transfer was the dominant heat transfer process for all but the smallest fires. This conclusion is supported by the data of Yumoto (1971) who reported that radiative and convective contributions were equal for pool fires of gasoline with 0.6-m diameters, but at 3-m diameter radiation was contributing 70% of the total heat transferred back to the slick. Babrauskas (1988) also reports that burning pools of diameter greater than 0.2-m are dominated by radiation heat transfer.

Based on a review of laboratory data on radiation from pool fires of hydrocarbons Battelle (1979) concluded that about 2 to 3% of the heat of combustion of a liquid fuel is radiated back to the surface. Twardus & Brzustowski (1981) showed that theoretically the heat radiated back to the pool surface from a flame with a height equal to twice the pool diameter would be 2.2% of the heat of combustion of the fuel. This is in agreement with the Battelle conclusion.

Evans et al. (1988) measured the incident radiant energy flux at the center of a 1.2-m diameter burning slick of Alberta crude as 40 to 65 kW/m² and 18 kW/m² at the rim of the test pan with a burning rate of 1.6 mm/min (1.5 kg/min). They calculated that the heat required for vaporization was 6.7 kW/m² and the heat loss by conduction through the slick to the underlying water was 2.5 kW/m²; the remainder of the heat was likely reradiated or convected away. The measured total heat release rate for the burn during steady state was 1.25 MW or 1.1 MW/m² of pool surface. The fraction of heat released that was radiated back to the pool surface ranged from 0.016 at the rim to 0.036 to 0.05 at the center, in good general agreement with the Battelle conclusions. The higher than expected fraction may be related to the fact that this calculation used a measured total heat output instead of a heat of combustion calculation. Wakamiya et al. (1982) reported that, in 2-m diameter, 50-mm thick test burns of six crude oils on water, just before the flames extinguished the fraction of the heat of combustion being radiated back to the slick was between 0.01 and 0.021.

Thus, only a small fraction of the heat generated by the vapour-phase combustion is returned to the slick to maintain the process and most of this is by radiation; the vast majority of the heat of combustion is radiated and convected away.

Heat that is radiated back to the slick is used to vaporise liquid oil to provide fuel for combustion in the air above the slick. Extensive tests by Wakamiya *et al.* (1982) showed that the process by which oil vaporizes is not a distillation (whereby the lightest, most volatile components are boiled off from the entire slick first followed by progressively heavier, less volatile components) but is similar to an Equilibrium Flash Vaporization (EFV) in which vapour of essentially constant composition over time is produced by boiling liquid oil of essentially constant composition. Three observations lend credence to the EFV theory of combustion: (1) the surface temperatures of burning oil slicks remain almost constant in the 200 to 300°C range during steady state burning (Wakamiya *et al.*, 1982; Evans *et al.*, 1988; SINTEF & SL Ross, 1993), if burning were a distillation the surface temperature of the slick would steadily increase; (2) a steep temperature profile in the burning slick (Wakamiya *et al.*, 1982; SINTEF & SL Ross, 1993), indicating a poorly-mixed oil layer, as would result from EFV; and (3) the presence of some lighter ends in the oil residue remaining after a burn (Energetex, 1977; Dome Petroleum, 1981; Wakamiya *et al.*, 1982; Fritt-Rasmussen *et al.*, 2012) which would not be present if in situ burning was a distillation process. It is believed that EFV occurs during in situ burning because the hot flames and the insulating characteristics of the oil combine to create high heat inputs to the oil surface layer and high surface temperatures in a layer known as the "hot zone". This promotes near-complete vaporization of successive layers of the oil slick with minimal mixing and heat transfer to the underlying oil and/or water layers.

In summary, the steady state phase of in situ burning is controlled by radiant heat transfer from the flames back to the surface of the burning slick; this heats and vaporizes a thin surface film of oil which subsequently burns in the air above the slick.

4.2 Steady-State Oil Removal Rates

The rate at which in situ burning consumes oil is generally reported in units of slick thickness burned per unit time (mm/min is the most commonly used unit). The removal rate for in situ oil fires is a function of fire size (or diameter), slick thickness, oil type and ambient environmental conditions.

Blinov & Khudiakov (1959) in Russia studied pan fires¹ of a range of petroleum products to determine the effects of fire diameter on oil removal rate. Their data, shown in **Figure 4.2** shows an initial decrease in burn rate with increasing size, followed by a minimum at about a 10-cm pan diameter, then a subsequent increase to a constant rate of about 4 mm/min above a 2-m fire diameter (up to a maximum diameter of 22.9-m). **Figure 4.3** shows data from in situ burn tests involving fresh unemulsified thick (10 to 50-mm) slicks of crude oils on water superimposed on the graph of Blinov and Khudiakov (McAllister & Buist, 1981; SL Ross & Energetex, 1986; Wakamiya *et al.*, 1982; Evans *et al.*, 1992; SL Ross, 1989; SINTEF & SL Ross, 1993; Bech *et al.*, 1992; Koseki & Mulholland, 1991). It is clear that the data follow the same trend as that of Blinov & Khudiakov (1959). Koseki & Mulholland's (1991) curve (**Figure 4.4**) appears to reasonably correlate the data (considering the range of experimental conditions and crude oil types

¹ Pan fires are equivalent to oil fires on water when the oil slick is thicker than a few mm.

involved). One data set inexplicably differs significantly from the curve: the 2-m diameter burn rates reported by Wakamiya *et al.* (1982) of 3 to 4.9 mm/min

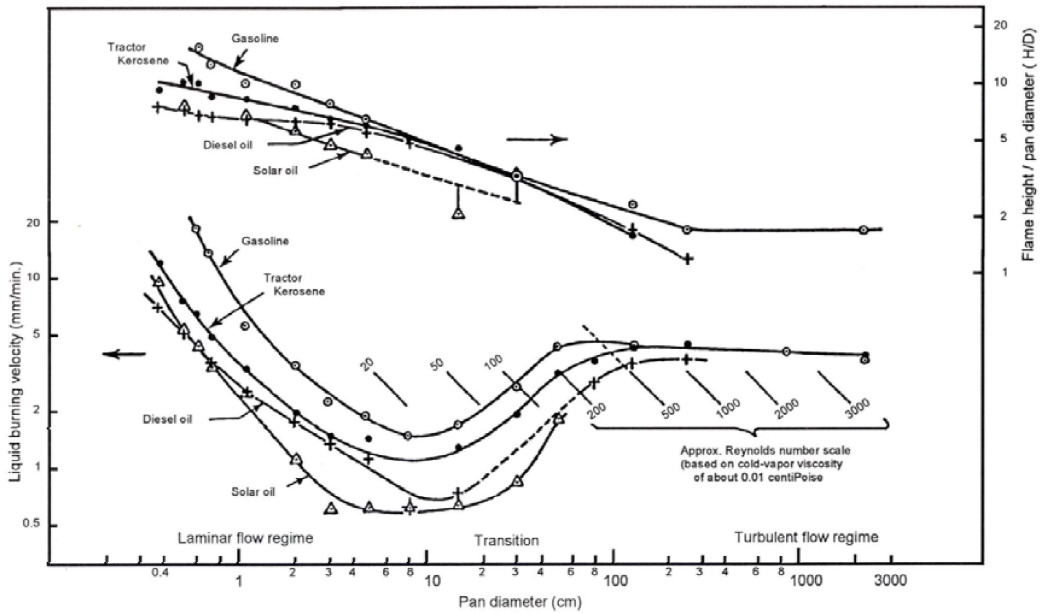

Figure 4-2 Burning data (from Blinov & Khudiakov 1959). (Source: Marine Spill Response Corporation)

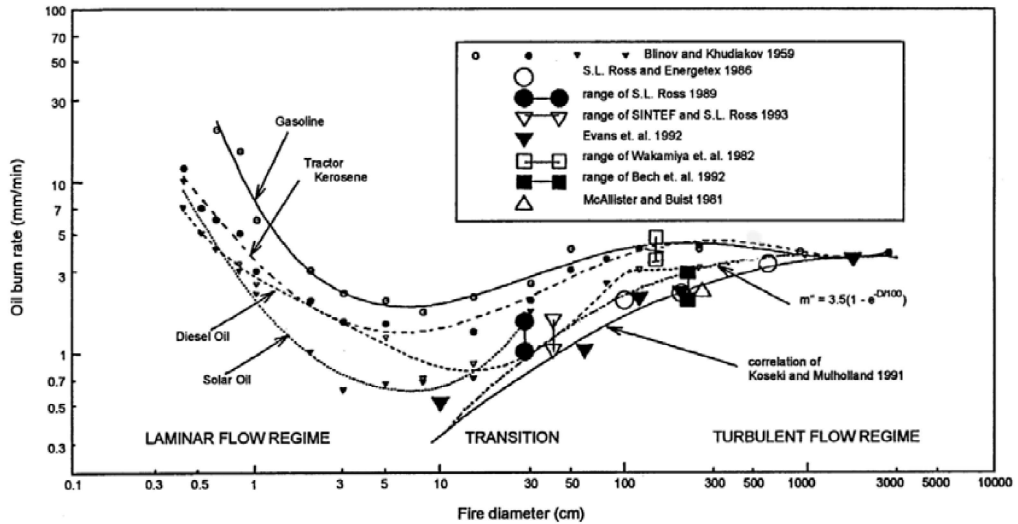

Figure 4-3 Burning rate vs. fire diameter - a comparison of data sets. (Source: Marine Spill Response Corporation)

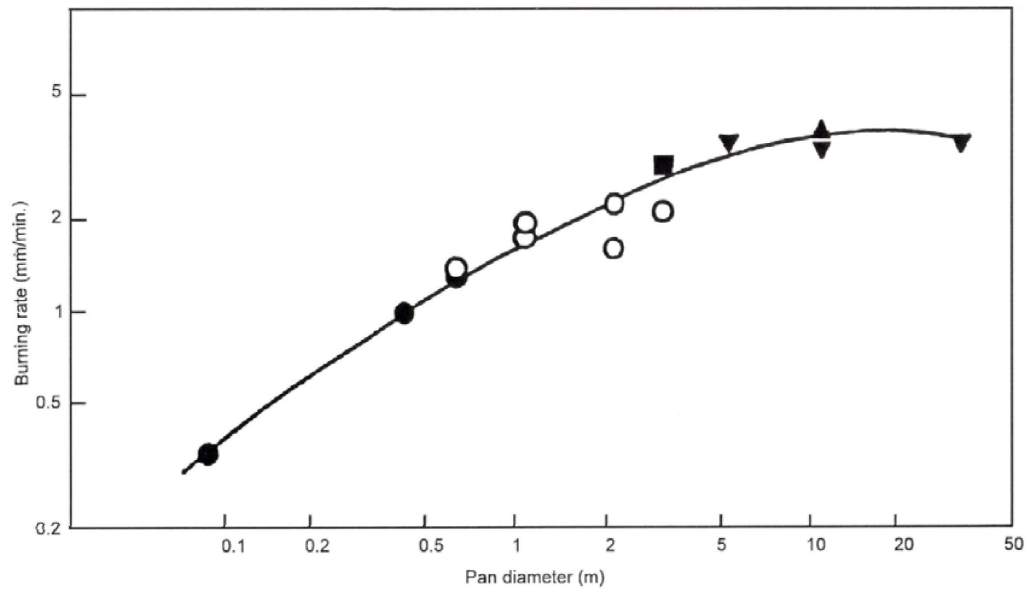

Figure 4-4 Relationship between burning rate and tank diameter (from Koseki & Mulholland, 1991).
(Source: Marine Spill Response Corporation)

are somewhat higher than the correlation and other data (e.g., Evans *et al.*, 1992; and Bech *et al.*, 1992) which would suggest a 2 to 2.5 mm/min burn rate for this diameter.

Babrauskas (1988) gives the following equation to correlate the burning rate of hydrocarbon pool fires in the open with $D > 0.2$ m:

$$\dot{m}'' = \dot{m}''_{\infty} (1 - e^{-k\beta D}) \tag{4-1}$$

where:

- \dot{m}'' = mass burning rate [$\text{kg}/\text{m}^2\text{s}$]
- \dot{m}''_{∞} = mass burning rate at infinite diameter [$\text{kg}/\text{m}^2\text{s}$]
- $k\beta$ = constant for a given fuel [m^{-1}]
- D = pool diameter [m]

Values for \dot{m}''_{∞} and $k\beta$ for different fuels may be found in [Table 4-1](#).

Employing the commonly-used in situ burn rate expressed in mm/min (i.e., \dot{m}'' converted to \dot{r}'' via the fuel density); with an \dot{r}''_{∞} of about 3.5 mm/min for crude oil, as suggested by the data of Koseki and Mulholland (1991) and Evans *et al.* 1992 and 1993, an equation of the form:

$$\dot{r}'' = 3.5 (1 - e^{-D}) \text{ [mm/min]} \tag{4-2}$$

where:

- \dot{r}'' = burning oil slick regression rate (mm/min)
- D = pool diameter [m]

approximates the Koseki & Mulholland (1991) correlation and other reserachers crude oil data well, for $D > 0.2$ -m as shown on [Figure 4.3](#). For most large fires of unemulsified crude oil on water, the "rule-of-thumb" is that they burn at 3.5 mm/min. Babrauskas (1988) notes that for

very large pool diameters, greater than 5 or 10 m, a decrease in pool burning rate on the order of 20% can be observed. This is attributed to poorer mixing, poorer combustion and a layer of cold smoke above the pool surface. Data from Walton *et al.* (1993) and Koseki & Mulholland (1991) can be interpreted as indicating a slight reduction in burn rate with increasing diameter over 10 m; the reduction is much less than 20% and possibly within the experimental measurement error. Akita & Yumoto (1965) observed that the burning rate of a pool fire is a function of distance from the center of the fire. Their research indicated that pool fires burn fastest at the periphery and slowest at the center of the fire due to lack of air at the center. They postulate that this causes a radial flow of fuel from the center of the fire outwards.

Slick thickness also affects burn rates, with thicker slicks burning faster than thinner slicks. Data presented in SL Ross & Energetex (1986) show an increase in overall burning rate for constant fire diameter (1 or 2-m) with increasing slick thickness up to about 10-mm; above this the burn rate does not appear to be a function of slick thickness. This has been confirmed by Garo *et al.* 1994 and Torero *et al.* 2003. Evans *et al.* (1988) present data that imply that the peak, or "vigorous", burning rate increases with thickness up to 10-mm, but an increase from 5 to 10-mm does not increase steady state burning rates for 0.6 and 1.2-m diameter fires (see below). SL Ross (1989) show that overall burning rate increases for small diameter fires (28-cm) with increasing slick thickness up to 10-mm. Analysis of mesoscale burn data presented in Evans *et al.* (1992) indicates that there is no increase in overall burn rate with thickness for slicks 18 to 90-mm thick and 6.9 to 17.2-m in diameter.

Review of available data for slicks less than 10-mm thick indicates a slight decline in overall burn rate of about 10% with a decline in slick thickness from 10-mm to 5-mm and a 50% reduction with a decline to a 2-mm slick thickness. This suggests a relationship between initial slick thickness and burn rate of the form:

$$\dot{r}'' = \dot{r}''_{\infty}(1 - e^{-cx}) \quad (4-3)$$

where:

- \dot{r}'' = average or overall burn regression rate at slick thickness x [mm/min]
- \dot{r}''_{∞} = burn regression rate at large (>10-mm) slick thickness [mm/min]
- c = a constant [mm⁻¹]
- x = initial slick thickness [mm]

A value of $c = 0.35\text{-mm}^{-1}$ gives the correct general shape of the curve.

Oil type and degree of oil weathering are also known to affect overall burning rate. Blinov & Khudiakov (1959) found that different petroleum products burn at different rates, at least in fires less than 2-m in diameter (see [Figure 4-2](#)). Babrauskas (1988) gives m''_{∞} data for a variety of petroleum products (see [Table 4.1](#)). Note that these are for pool fires rather than in situ fires and thus would be somewhat lower than the overall in situ burning rate, if a vigorous burn phase occurs. Wakamiya *et al.* (1982) found that overall burning rates for six crudes ranged from 3.0 to 4.9 mm/min. It is interesting to note that both data sets show no correlation between density (i.e., volatility) and burning rate. It may be that over the range of fuels tested, flame temperature and smoke obscuration differences among fuels play a stronger role in determining burning rate than fuel density. The only trend in the data sets is the tendency of residual fuel oils to burn at lower rates (2 mm/min) than either lighter products or crudes.

Table 4-1: Data for Large-Pool Burning Rate Estimates*					
Material	Density (kg/m ³)	Δh_c (MJ/kg)	m''_{∞} (kg/m ² s)	r''_{∞} (mm/min)	$k\beta$ (m ⁻¹)
Petroleum Products:					
benzene	740	44.7	0.048	3.9	3.6
gasoline	740	43.7	0.055	4.5	2.1
kerosene	820	43.2	0.039	2.9	3.5
JP-4	760	43.5	0.051	4.0	3.6
JP-5	810	43.0	0.054	4.0	1.6
transformer oil	760	46.4	**0.039	**3.0	**0.7
fuel oil, heavy	940-1000	39.7	0.035	2.1	1.7
crude oil	830-880	42.5-42.7	0.022-0.045	1.6-3.3	2.8
* Adapted from Babrauskas (1988)					
** Estimate uncertain since only two data points available					

Evaporation of light ends from oil has little effect on burning rates. Wakamiya *et al.* (1982), SL Ross (1989), and Evans *et al.* (1992), all indicate that there is no effect of loss of light ends through weathering of the slick on overall burn rate. Bech *et al.* (1992) indicate a slight decrease in burn rate with increasing evaporation but note that environmental factors may be the cause of this. SINTEF & SL Ross (1993) show no consistent dependence of burn rate on degree of weathering. Garo *et al.* (2004) show a slight decrease in burning rate in small-diameter burns with increased evaporation.

Environmental factors affect burning rates somewhat. Ambient temperature effects are generally small in magnitude. Wakamiya *et al.* (1982) indicated an average reduction in burning rate of 15% for an ambient temperature decline of 25°C for four crude oils. This is presumably related to a combination of increased sensible heat requirements for warming the slick and increased heat conduction through the slick. Hall (1973) reports similar reductions for pool fires of benzene and toluene. Evans *et al.* (1988) present data for 1.2-m diameter crude oil fires at temperatures of 5 to 28°C. Although the trend is far from clear, a 10% reduction in burn rate with a 23°C ambient temperature drop is indicated.

Wind also affects burning rate. Babrauskas (1988) gives the following expression, based on data from Blinov & Khudiakov (1959), for the relationship between pool fire burning rate and wind speed, as a function of pool diameter:

$$\frac{m''_{winds}}{m''_{still}} = 1 + 0.15 \left(\frac{u}{D} \right) \quad (4-4)$$

where:

u = wind speed [m/s]

D = pool diameter [m]

This applies up to the blow-off velocity (the wind speed at which vapour is carried away faster than it can be replaced and the flame goes out), which can be as low as 5 m/s for some fuels. Evans *et al.* (1988) report an increase in the quiescent burning rate of a 1.2-m diameter fire of crude oil on water from an average 2.6 mm/min in a wind of 1 m/s up to 4 mm/min in a 2.5 m/s wind. Evans *et al.* (1992) present data that indicate no effect of a wind increase from 1 to 5 m/s on 6.9-m to 17.2-m diameter crude oil fires on water; this is broadly consistent with **equation 4-4**. Both Allen (1986) and Bech *et al.* (1992 and 1993) report the maximum wind speed at which crude oil will burn (i.e., the blow-off velocity) is about 10 to 12 m/s.

Wave action may also reduce burning rates, by increasing heat transfer to the underlying water. This effect has been noted by Tam & Purves (1980) in small spills (<5 L) in small (5 and 10-cm) waves. Buist & McAllister (1981) reported reduced burn times at constant tow speeds with increasing regular wave height from 0 to 0.4-m x 19-m (height x length), but reported no decrease in visible combustion intensity. These tests involved burning 38 to 57-L (0.24 to 0.36 bbl) of crude oil in a fire resistant boom at the OHMSETT test facility. Increased residue amounts were also reported, but not quantified, so the decreased burn times may be related to earlier extinction of the fire rather than to reduced burning rates. Bech *et al.* (1993) reported no effects of 40-cm x 4-m waves on the burning of 4-m³ of unemulsified crude oil in a 300-m² test pit but a considerable reduction in burn intensity for a 25% water emulsion in waves.

In small-scale tests (40-cm diameter burns) in waves SL Ross (1998) reported that increases in wave steepness tended to increase the burn rate of thicker slicks (10 to 20-mm) of water-free crude oil but had no effect on thinner (2 to 5-mm) slicks. In larger-scale tests (1.7-m diameter) burn rates decreased slightly with increasing wave steepness. The effect of waves on burn rate is thus unclear, and for thick, large slicks of unemulsified oil it may be negligible.

Buist & McAllister (1981) showed that the effects of currents on in situ burning rates are negligible, up to a relative velocity between the slick and underlying water of up to 1 m/s (conventional containment equipment normally fails to contain oil at relative velocities of 0.35 to 0.5 m/s). Preliminary results from field trials in Norway (SINTEF & SL Ross, 1993) support this conclusion.

In summary, wind speed and ambient temperatures can affect in situ burn rates to some extent, currents do not seem to affect burning rates, and it is unclear whether or not wave action affects burning rates. **Table 4-2** summarizes the present “rules of thumb” for burning rates (Buist *et al.*, 2003).

Table 4-2: Summary of In situ Burning Rates for Unemulsified Oil Spilled On Water.	
Oil Type/Condition	Burn/Removal Rate ⁺
Gasoline > 10-mm thick	4.5 mm/min
Distillate Fuels (diesel and kerosene) > 10-mm thick	4.0 mm/min
Crude Oil > 10-mm thick	3.5 mm/min
Heavy Residual Fuels > 10-mm thick	2.0 mm/min
Slick 5-mm thick*	90 percent of rate stated above
Slick 2-mm thick*	50 percent of rate stated above

Table 4-2: Summary of In situ Burning Rates for Unemulsified Oil Spilled On Water.	
Oil Type/Condition	Burn/Removal Rate ⁺
* Estimates of burn/removal rate based on experimental burns and should be accurate to within ± 20 percent.	
* Thin slicks will naturally extinguish, so this reduction in burn rate only applies at the end of a burn.	

4.3 The Vigorous Burning Phase

As noted above, during oil slick burning the oil layer acts as insulation between the hot vapour/liquid interface and the oil/water interface. This is true while the slick is thick (>5 to 10-mm), but once the slick thins as burning progresses, the "hot zone" approaches the water surface and increasing amounts of heat are transferred into the water column. This process is illustrated in **Figure 4.5**. As the rate of heat transfer increases the temperature of the layer of water directly beneath the slick increases. The presence of the oil layer allows the water to be heated above its boiling point (superheating) and once a temperature of approximately 120°C is reached, the water begins to boil violently. The generated steam vigorously mixes the remaining oil layer and ejects oil droplets into the flames. This results in increased burn rate, flame height and radiative output (Energetex, 1977; Wakamiya et al., 1982; Evans

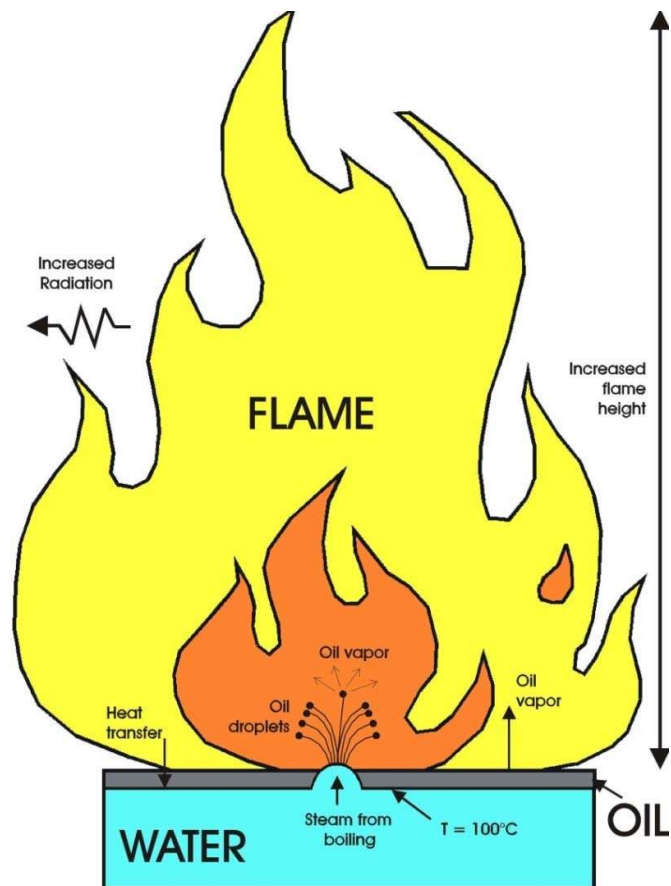

Figure 4-5 Development of the vigorous burning phase. (Source: Marine Spill Response Corporation)

et al., 1988 and 1992; Garo et al., 1994; Garo et al., 1999; Garo et al., 2007). Evans et al. (1988 and 1992) and Garo et al. (1994) have studied this end-phase of in situ burning extensively and have shown that:

- Burning rates increase by up to 400% during the vigorous burning phase, likely as a result of liquid oil droplets being ejected into the flames by the action of the underlying boiling water.
- The increase in burn rate during the vigorous burning phase appears to be an inverse function of fire size -- the increase is a factor of two for a diameter of 0.6-m, a factor of 1.8 for a diameter of 2-m, and a factor of 1.3 at a diameter of 17-m.
- Heat release rates and flame heights are consequently increased during the vigorous burning phase.
- For small fires up to 10-mm in initial thickness the duration of the vigorous burning phase is relatively unaffected by initial slick thickness, but the intensity of the vigorous burn phase increases with increasing slick thickness (see [Figure 4.6](#); next page); for larger fires up to 90-mm thick there seems to be a trend of an increased length of vigorous burn with increasing slick thickness (but not diameter). This would make sense as the depth of the "hot zone" in the thicker slicks would increase with time leading to a longer vigorous burning phase

One effect of the vigorous burning phase that has been observed is foaming of the burning oil, followed by rapid extinguishing of the flames (SL Ross, 1989; SINTEF & SL Ross, 1993; Energetex, 1980; Hall, 1973; Garo et al., 2004). This appears to be a phenomenon related to oil type, with the presence of water in the burning oil a key contribution to foaming (SL Ross, 1989; Energetex, 1980; SINTEF & SL Ross, 1993; Garo et al., 2004).

The onset of a vigorous burn phase has never been observed in a towed fire boom (i.e., at the *Exxon Valdez* test burn, the DWH burns or any experimental burn in a towed fire boom) or a burn in currents, likely because water flow under the burning slick prevents the water from heating enough to boil. A vigorous burn phase has been observed in melt pools.

4.4 Oil Removal Efficiency and Residue Amounts

Oil removal efficiency, defined as the percentage of the original oil that was ignited that is remaining after the flame extinguishes, is primarily a function of three factors: the initial thickness of the slick; the thickness of the residue remaining after extinction; and, flame coverage of the slick. Other secondary factors include environmental effects such as wind and current herding of slicks against barriers and temperature effects. Flame spreading is discussed in the succeeding section.

The dependence of burn efficiency on initial thickness is straightforward for the case of a fully ignited slick in a relatively quiescent environment:

$$\% \text{ removed} = (1 - x_r/x_o) 100\% \tag{4-5}$$

where:

- X_o = initial slick thickness [mm]
- X_r = residue slick thickness [mm]

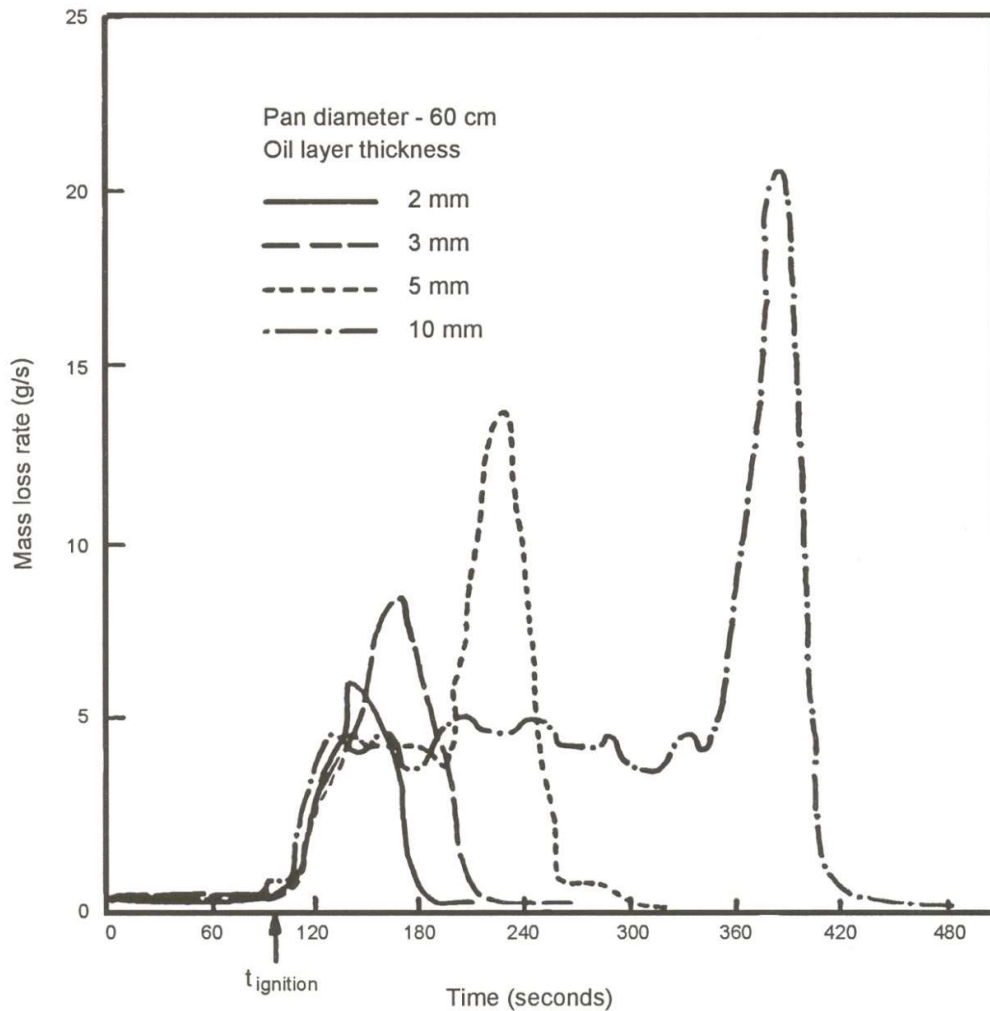

Figure 4-6 Effect of oil layer thickness on mass loss rate (fuel) for crude oil fires (from Evans *et al.*, 1988). (Source: Marine Spill Response Corporation)

For constant residue thickness, it is seen that burn efficiency is simply dependent on the initial thickness of the slick. Numerous investigations have studied the effects of various parameters on residue thickness and burn efficiency (e.g., Maybourn, 1971; Energetex, 1980; Wakamiya *et al.*, 1982; SL Ross & Energetex, 1986; Evans *et al.*, 1986, 1987, 1988, 1992 and 1993; Smith & Diaz, 1985 and 1987; Bech *et al.*, 1992). The major results from these studies are discussed below.

Residue thickness is a weak function of initial thickness in quiescent burns. Up to an initial thickness of about 40-mm, residue thickness is approximately constant at 1-mm; for initial thicknesses greater than about 40-mm, residue thickness increases with increasing thickness. Data from SL Ross & Energetex (1986) (see [Figure 4.7](#)) show no clear correlation of increasing residue thickness with increasing initial thickness for 1 and 2-m diameter burns. Data from Evans *et al.* (1992) ([Figure 4.7](#)).

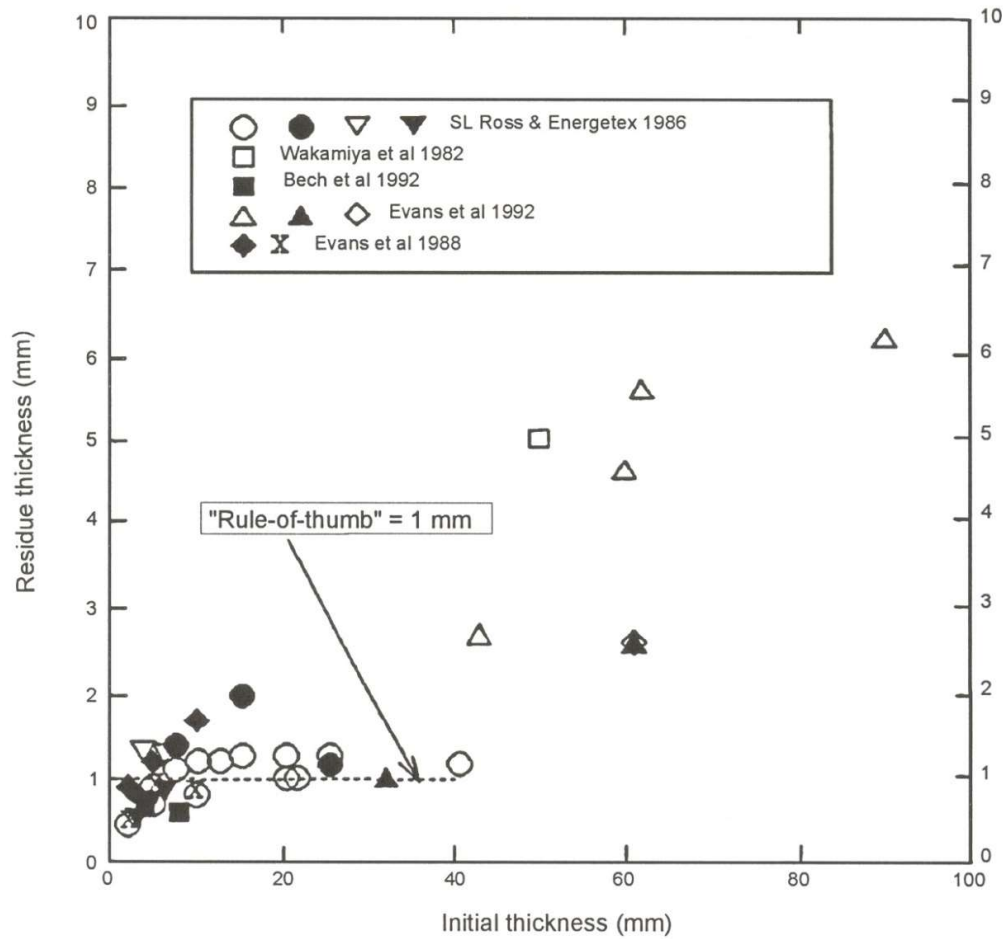

Figure 4-7 Residue thickness as a function of initial slick thickness. (Source: Marine Spill Response Corporation)

indicate an increase in residue thickness with initial thickness for 7-m diameter fires. Data from Wakamiya *et al.* (1982) (2-m diameter, 50-mm initial thickness, average of six crudes) are also shown on [Figure 4.7](#)

There may be a dependence of residue thickness on oil type. Energetex (1980) reports that residue thicknesses for Bunker C fuel were two to three times greater (2-mm) than for equivalent burns of crude oils and diesels (0.5 to 0.8-mm). Wakamiya *et al.* (1982), however, reported no difference in residue thickness (5-mm) between crude oil and Bunker "C" for initially thick (50-mm) burns. SL Ross & Energetex (1986) report no observable difference between residue thickness remaining after diesel and crude oil burns. The differences in the oils that cause differences in residue thickness may be overshadowed by the "hot zone" formation in initially thick, large fires.

Degree of evaporation does not seem to be a factor in unemulsified oil burn residue thickness (Energetex, 1980; SL Ross, 1989; Evans *et al.*, 1992; Cabioc'h, 1993) with the possible exception of the case of thin slicks of highly weathered oil (Bech *et al.*, 1992).

Environmental factors also can affect the thickness, or amount, of residue remaining. The key factors for unemulsified oils are wind and currents. The action of these two forces is to continuously herd a slick against a barrier, thus thickening the oil as it burns down. The phenomenon of "wind herding" is well known and the efficiency of wind to herd oil against a barrier has been extensively studied (Energetex, 1981) and modelled (Energetex, 1981; SL Ross & Energetex, 1986). It is the phenomenon of a self-induced wind (that is drawn in by the combustion process and the rising column of hot gases) keeping an uncontained slick at burnable thicknesses that is the basis for the theory of "uncontained" in-situ burning (SL Ross & Energetex, 1986). As little as a 2 m/s wind is capable of herding oil to thicknesses that will sustain combustion. The residue remaining after a burn against a barrier in winds 2 m/s or greater should be substantially less than in calm conditions, but as wind speed increases the flames are bent further over and the heat radiated back to the fuel surface decreases. The interfacial tension of oil decreases with increasing temperature as does its viscosity, both of which lead to a greater tendency for the oil to spread. The interplay of these factors results in only a small increase in burn efficiency with increasing wind speed for small diameter burns (Figure 4-8).

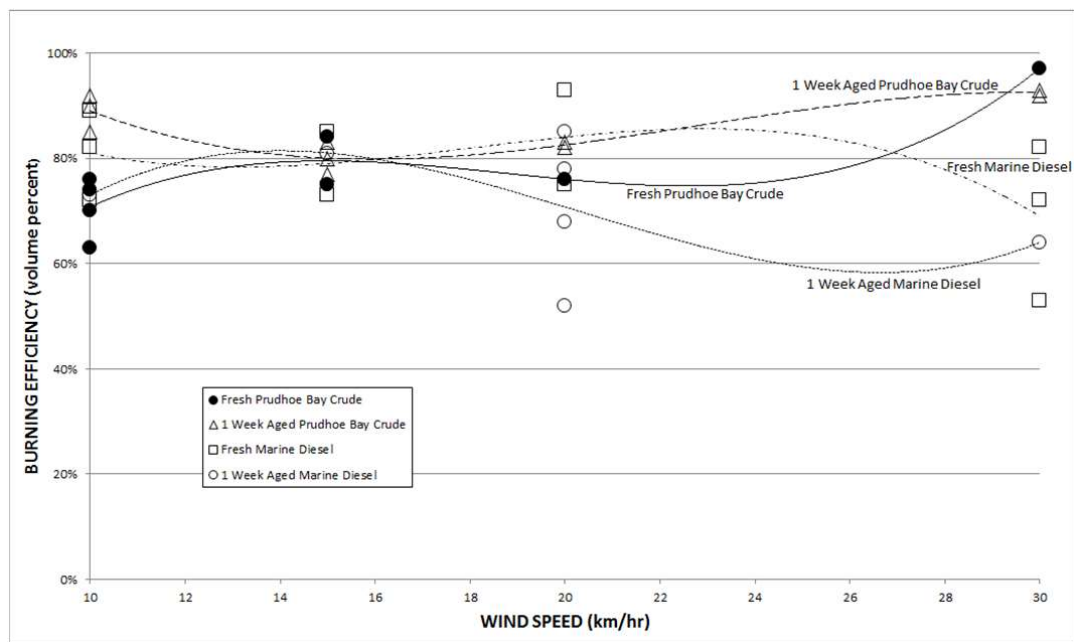

Figure 4-8 Removal efficiency vs. wind speed for 1m² burns (from Energetex 1981a). (Source: Marine Spill Response Corporation)

The beneficial effects of wind herding for large fires, noted by many researchers, can be noticed during the extinction phase of a burn. As the flames die down after the vigorous burning stage, the oil cools and, as it is pushed by wind against the barrier and thickens, it re-ignites (if some flames are still present) or can be re-ignited. This process can result in extremely high burn efficiencies (Dome, 1981; SL Ross & Energetex, 1986; Evans *et al.*, 1992).

Currents can also dramatically reduce the amount of residue remaining by herding oil against a barrier. Although this phenomenon has not been thoroughly researched, field trials (SINTEF & SL Ross, 1993; OSIR, August 18, 1993) suggest that burning against a barrier in currents can result in very low amounts of residue. The detrimental effects of currents on the amount of

residue could include entrainment of residue beneath a floating barrier as the residue density and viscosity increase during the burn process (SINTEF & SL Ross, 1993) and overwashing of the burning slick, causing extinction of the flames (Energetex, 1981; SINTEF & SL Ross, 1993).

Ambient temperature does not seem to affect the amount of residue remaining. Comparison by Wakamiya *et al.* (1982) of burn efficiency data from two test sites with a 25°C ambient temperature difference showed no difference. Similar results were obtained by Evans *et al.* (1988) over a 23°C temperature difference.

The effects of waves on residue remaining seem to be a function of the scale of the burn and the type of wave. Tam & Purves (1980) noted that steep, 5-cm waves resulted in a reduction in burn efficiency from 84% to 24% for 1-m diameter burns; steep, 10-cm waves further reduced the efficiency to 10%. Tests of a fire resistant boom at OHMSETT with 38-L of oil in a 2-m diameter semi-circle showed increased residue amounts with increasing wave height (0.2-m x 19-m swell and 0.4-m x 19-m swell). Choppy waves extinguished burning slicks. Tests with a 13-m diameter slick of unemulsified crude oil in 40-cm x 3 to 4-m long regular waves (Bech *et al.*, 1993) resulted in a 90% burn effectiveness (including the effects of wind herding). In small-scale tests (40-cm diameter burns) in waves SL Ross (1998) reported that increases in wave steepness tended to increase the amount of burn residue for all slick thicknesses and degrees of evaporation of the crude oil slicks. In larger-scale tests (1.7-m diameter) amounts of burn residue remaining also increased slightly with increasing wave steepness. Presumably the detrimental effect of waves relates to increased heat transfer through the slick causing earlier slick cooling.

In summary, burn efficiency is a strong function of initial slick thickness; anything that serves to thicken or contain the burning oil results in improved burn efficiencies. Residue thickness, or amount, is the other factor that dictates burn efficiency. A good "rule-of-thumb" is that the residue is 1-mm thick for initial slick thicknesses of up to 40-mm; above this the residue thickness increases to about 6-mm for a 100-mm thick slick in quiescent conditions. The action of winds (from 2 to 12 m/s) and gentle currents (up to 0.4 m/s) can greatly reduce the amounts of residue remaining after a burn against an edge (such as an ice edge or fire boom). Wave action may be detrimental to burn efficiency, even for contained slicks, particularly if the waves are short, steep, and choppy.

Residue Rules of Thumb

- For pools of unemulsified crude oil up to roughly 40-mm in thickness the residue thickness is on the order of 1-mm;
- For thicker crude slicks the residue is thicker; for example, 3 to 5-mm for 50-mm thick oil and 6-mm for 100-mm thick oil;
- For emulsified slicks the residue thickness can be much greater (see below); and,
- For light and middle-distillate fuels the residue thickness is 1-mm, regardless of slick thickness.

4.5 Oil Slick Ignition and Flame Spreading

4.5.1 Oil Slick Ignition

An important goal in in situ burning of oil is to ignite the maximum possible area of the slick. Ignition involves heating the slick to a temperature high enough that the liquid hydrocarbons are vaporizing fast enough to generate a concentration in the air layer above the slick that is great enough to support burning (the Lower Flammability Limit or Lean Flammability Limit) then providing ignition energy to initiate burning. It should be noted that, as the temperature of the oil rises and its vaporization rate increases, the concentration of fuel vapours above the slick can exceed the Upper Flammability Limit or Rich Flammability Limit and the vapours will not burn until more air diffuses into the mixture. This may be a process that occurs in the center of large diameter in situ fires during steady burning. The temperature at which the slick produces vapours at a sufficient rate to catch fire is called the Flash Point. At a temperature (called the Fire Point) a few degrees above the Flash Point the oil is warm enough to supply vapours at a rate sufficient to support continuous burning (Kanury, 1988). The ambient temperature of a slick and its Flash Point are extremely important considerations for in situ burning from ignitability and safety perspectives.

Ignition of an oil slick and subsequent flame spreading are strong functions of the temperature of the slick, its volatility, its degree of emulsification, and the location of the ignition on the slick relative to the wind. If oil is at a temperature above its flash point, ignition is simple and flame propagation is normally rapid; otherwise ignition and flame spreading can be slow and difficult.

For an oil slick on water at a temperature below its flash point, an igniter must heat the slick to above its flash point. This problem involves two aspects: heat transfer through the slick and convective motion effects induced in the heated slick (**Figure 4-9**). When an oil slick on water at a sub-flash temperature is exposed to a radiant heat/ignition source initially, the surface of the slick is heated. As soon as this happens, the warm oil (with a lower air/oil interfacial tension than the colder, underlying oil) begins to flow horizontally away from the heat source. Its place is taken by colder fuel rising up from beneath in convection-induced, gravity-driven flow. It has been shown that this convective flow is decreased with increasing oil viscosity and decreasing bulk oil surface tension (Murad *et al.*, 1970); thus, more viscous oils (all other factors being equal) are easier to ignite. In any case, as heated oil is flowing outward, heat is also simultaneously conducted and convected vertically through the oil slick to the underlying water. If the slick is sufficiently thick to insulate itself and allow the surface layer to heat to its flash point, the slick will start to burn in the vicinity of the igniter.

Extensive experimentation with a variety of oil types, igniters and environmental conditions (Maybourn, 1971; Energetex, 1978 and 1980; Allen, 1987; SL Ross, 1989; Bech *et al.*, 1993) have confirmed the following "rules-of-thumb" for oil ignition on water in relatively calm, quiescent conditions:

Ignition Rules of Thumb

- The minimum ignitable thickness for fresh crude oil on water is about 1-mm;
- The minimum ignitable thickness for aged, unemulsified crude oil and diesel fuels is about 2 to 5-mm;
- The minimum ignitable thickness for residual fuel oils, such as IFO 380 (aka Bunker "C" or No. 6 fuel oil) is about 10-mm; and,
- Once 1-m² of burning slick has been established, the fire can sustain itself without an external heat source.

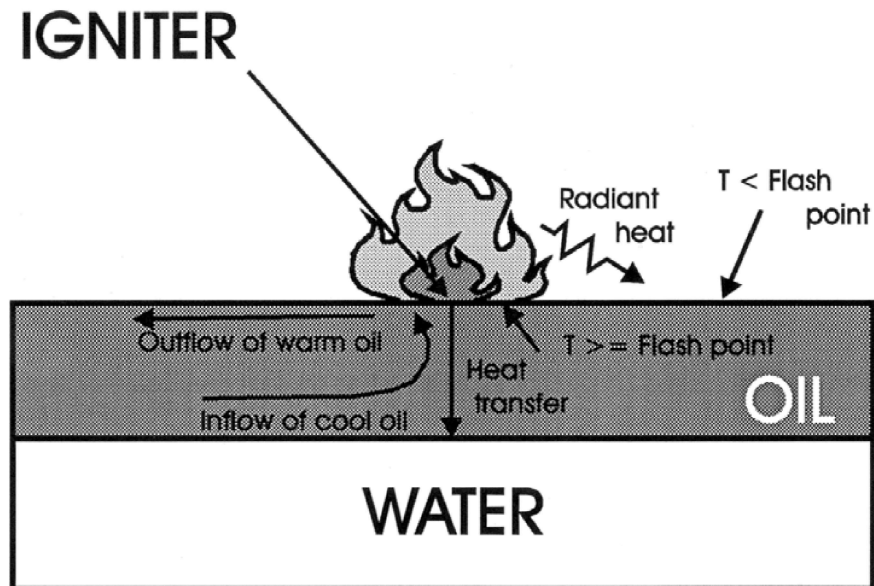

Figure 4-9 Heat transfer and convective motion during slick ignition. (Source: Marine Spill Response Corporation)

Note that although thick residual fuel oil slicks have been found to be ignitable, it is likely that efficient burning of a large spill of residual oil in situ will be extremely difficult unless promoters like diesel are first spread on its surface to enhance flame spreading.

Aside from oil type and thickness, other factors can affect the ignitability of oil slicks as well. The key parameters are: wind speed and igniter strength. Secondary factors include ambient temperatures and waves. Emulsification of oil affects ignitability but this is dealt with in a separate section.

The effects of wind speed on the ignitability of oil slicks have been studied both theoretically and experimentally. Murad *et al.* (1970) developed a mathematical model showing how the wind decreases the volume of ignitable vapours above the slick. Wind speed also reduces the ignitability of oil slicks at sub-flash temperatures possibly by increasing convective heat and mass transfer at the oil/air interface.

Energetex (1981) in tests with solid propellant igniters reported that, in an 8 m/s wind created by a fan adjacent to the slick (equivalent to an 11 m/s wind measured at a 10-m elevation) ignition of weathered crude and marine diesel slicks was not possible, even with slick thicknesses of 10-mm. For fresh crude oil a 2-mm slick was ignitable in a 3 m/s wind but not in an 8 m/s wind (equivalent to 11 m/s @ 10 m): the minimum ignitable thickness for fresh crude in an 8 m/s (11 m/s @ 10-m) wind was 5-mm. Allen (1987) reports that winds of 3 to 5 m/s did not affect slick ignition with small (60 to 120-mL) blobs of gelled gasoline; but, winds of 8 m/s required the use of 250 to 500-mL blobs to effect ignition. The maximum wind speed for successful ignition for large burns has been estimated as 10 to 12 m/s (Bech *et al.*, 1993; Cabioc'h, 1993).

Wave action can prevent ignition of marginally ignitable slicks (Tam & Purves, 1980; Energetex, 1981; Bech *et al.*, 1993). Energetex (1981) reports that the minimum ignitable thickness for one week aged Prudhoe Bay crude increased from about 3-mm in a 5 m/s wind to 10-mm with the application of 10-cm high waves.

Ambient temperature can also affect slick ignitability. If an oil slick is at a temperature above its flash point it will ignite rapidly and easily; however, oil slicks at sub-flash temperatures are more difficult to ignite. Ambient temperature has a greater effect on flame spreading velocity than on ignition, as discussed in the next section. Various devices and techniques have been developed for igniting oil slicks on water; a detailed discussion of these is reserved for a section in the next chapter.

4.5.2 Flame Spreading

Flame spread is a crucial aspect of effective in situ burning; if the fire does not spread to cover a large part of a slick, overall removal efficiency will be low. Flame spreading can be divided into two distinct categories: sub-flash spreading and super-flash spreading with an intervening transition zone characterized by pulsating spread. The dependence of flame spreading velocity on liquid temperature is shown in **Figure 4-10** (Akita, 1972) for methanol. At temperatures above the fluid's flash point, flame spreading is controlled by vapour phase effects. As the temperature rises from the flash point to the stoichiometric temperature (the liquid temperature required to produce vapour at a rate allowing combustion of stoichiometric amounts of fuel and oxygen) the flame spreading velocity increases from the laminar flame burning velocity at the lean flammability limit to a maximum that is on the order of the laminar flame burning velocity for a stoichiometric mixture of fuel vapour and air. For sub-flash fuel temperatures, the flame spreading velocity seems to be controlled by liquid-phase heat and mass transfer phenomena. Starting at a temperature well below the flash point (say -20°C on **Figure 4-10**) the flame spreading is controlled by the rate at which cold fuel in front of the flame is warmed by the advancing flame front. There are two mechanisms by which heat is conducted from

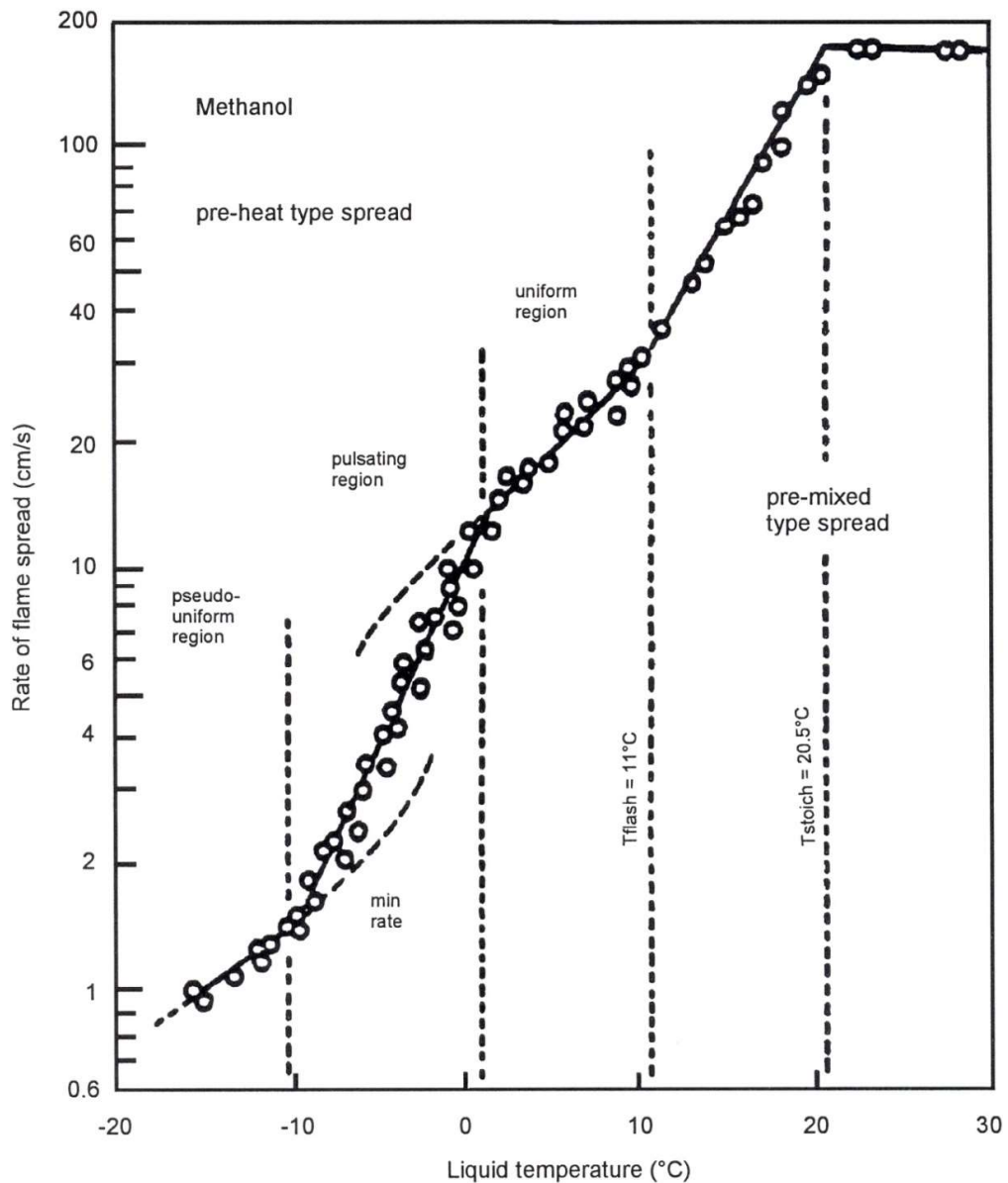

Figure 4-10 Relationship between the liquid temperature and the rate of plane flame spread of methanol in a vessel 2.6-cm wide and 1.0-cm deep. (Source: Marine Spill Response Corporation)

the flame to the cold fuel: radiation and convective flow (Glassman *et al.*, 1968; Sirignano & Glassman, 1970; Mackinven *et al.*, 1970; Akita, 1972). In the early stages of fire spreading over a sub-flash fuel on water, it is the convective flow process that dominates; for larger fires, the radiation of heat dominates (Mackinven *et al.*, 1970). **Figure 4-11** shows a schematic cross-section of an advancing flame that illustrates the processes involved for a quiescent sub-flash situation.

For small fires (and in the early stages of a larger fire), fuel underneath the leading edge of the flame front is hotter than the unignited fuel; as such, the hot fuel has a lower interfacial tension

than the cold fuel and tends to flow forward over it (Mackinven *et al.*, 1970; Glassman *et al.*, 1968; Torrance & Mahajan *et al.*, 1974). This is called the Marangoni effect. This interfacial tension flow outwards sets up a return flow of cold oil beneath the warm layer. As well, the combustion process itself sets up a bulk inward flow towards the fuel (Torrance & Mahajan, 1974). Additional resistance to the interfacial flow is provided by viscous dissipation in the warm fuel layer itself (Glassman & Hansel, 1968; Glassman *et al.*, 1969). **Figure 4-12** shows the dependence of flame velocity on fuel viscosity for a slick of kerosene at temperatures 40°C below its flash point (Glassman *et al.*, 1969). It is interesting to note that the flow-dissipating effects of increased viscosity aid in ignition of oil slicks (discussed in the previous section), but detract from subsequent flame spreading.

As the bulk temperature of the fuel approaches the flash point on **Figure 4-10**, the flame begins to pulsate. This pulsating region is characterized by a thin, blue "pre-mixed" flame travelling ahead of the yellow "diffusion" flame front (**Figure 4-11**). Akita (1972), Glassman & Hansel (1968), and Mackinven *et al.* (1970) state that for hydrocarbon fuels this pulsating flame relates to the difference between the flash and fire points of the fuel. As the oil surface in front of the flame front heats up to the flash point, the flame flashes forward, consumes the vapour and flashes back. A few degrees warmer and the fuel temperature exceeds its fire point and continuous burning begins.

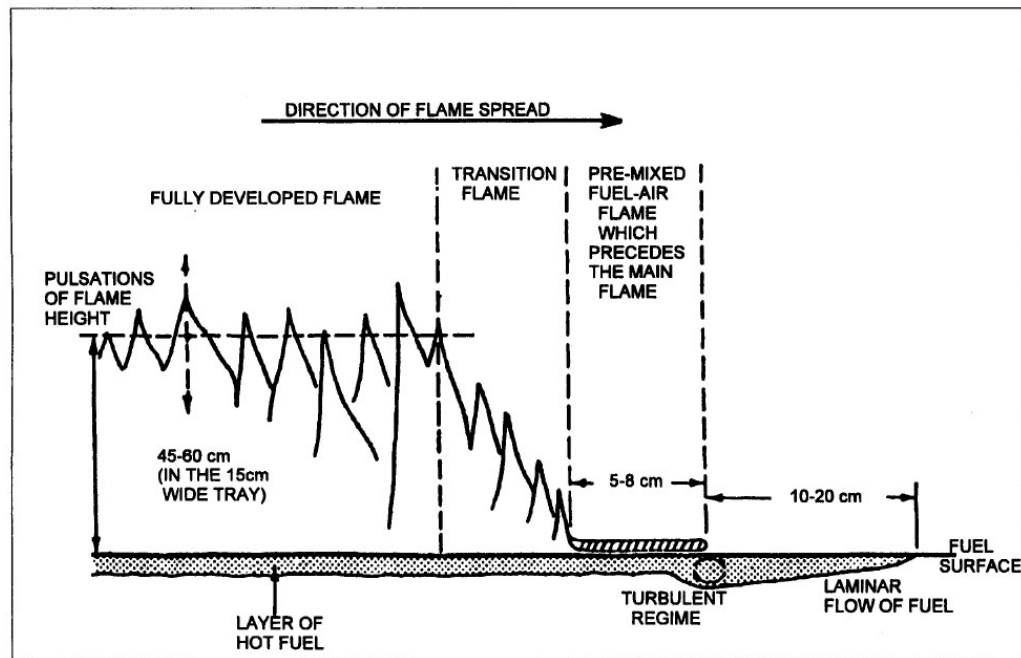

Figure 4-11 Schematic representation of the spreading flame. (Source: Marine Spill Response Corporation)

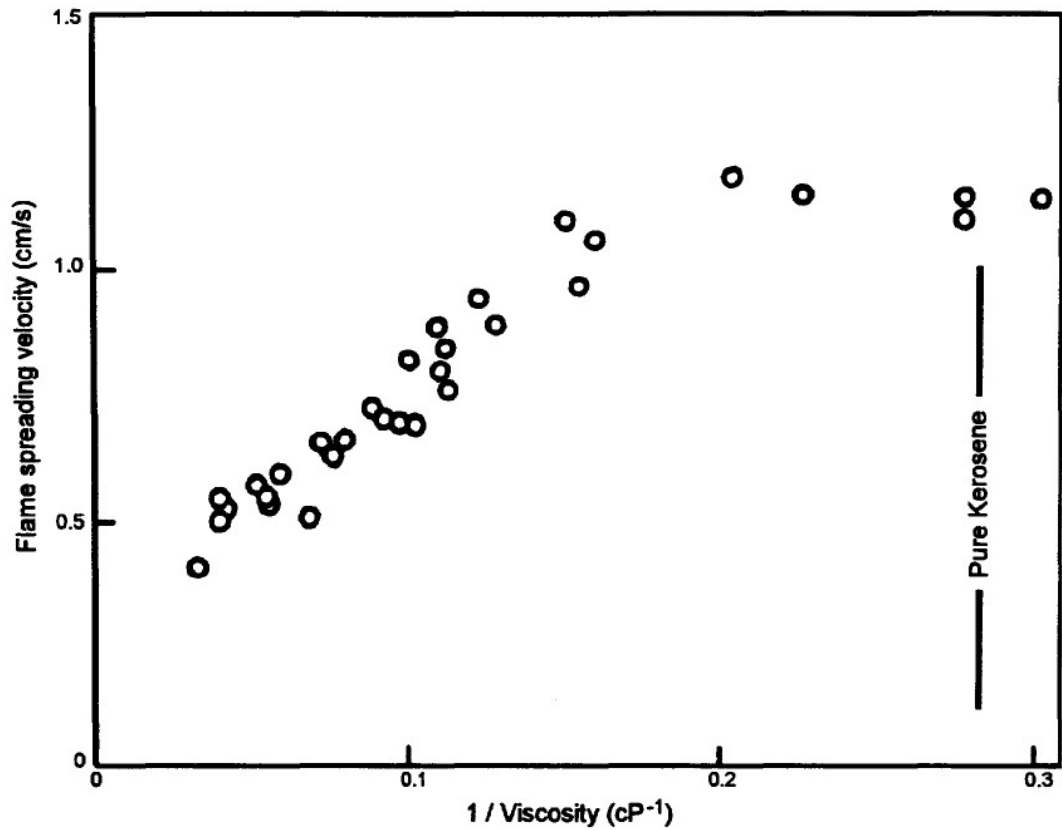

Figure 4-12 The flame spreading rate across thickened kerosene surfaces at room temperature (21°C) as a function of viscosity. A 3.5-mm kerosene film floated on 7.0-mm of water (from Glassman *et al.*, 1969). (Source: Marine Spill Response Corporation)

Many in situ burning studies (e.g., Energetex, 1977-1981; Evans *et al.*, 1986, 1988, and 1992; SL Ross, 1989; SINTEF & SL Ross, 1993) have measured flame spreading rates as the time for the flame to cover the entire surface of the slick and denoted this as ignition time. Their results indicate that, in quiescent conditions:

- as oil weathering increases, ignition time increases (i.e., the difference between ambient temperature and the oil's flash point increases, decreasing the flame spreading velocity);
- ignition times decrease with increasing slick thickness; and,
- for a constant thickness and flash point, increasing viscosity reduces flame spreading rates.

SL Ross & Energetex (1986) used a small wind tunnel to study flame spreading velocities and the effects of wind and ambient temperature. Their results for a fresh and weathered (unemulsified) crude and diesel fuel are shown on [Figure 4-13](#).

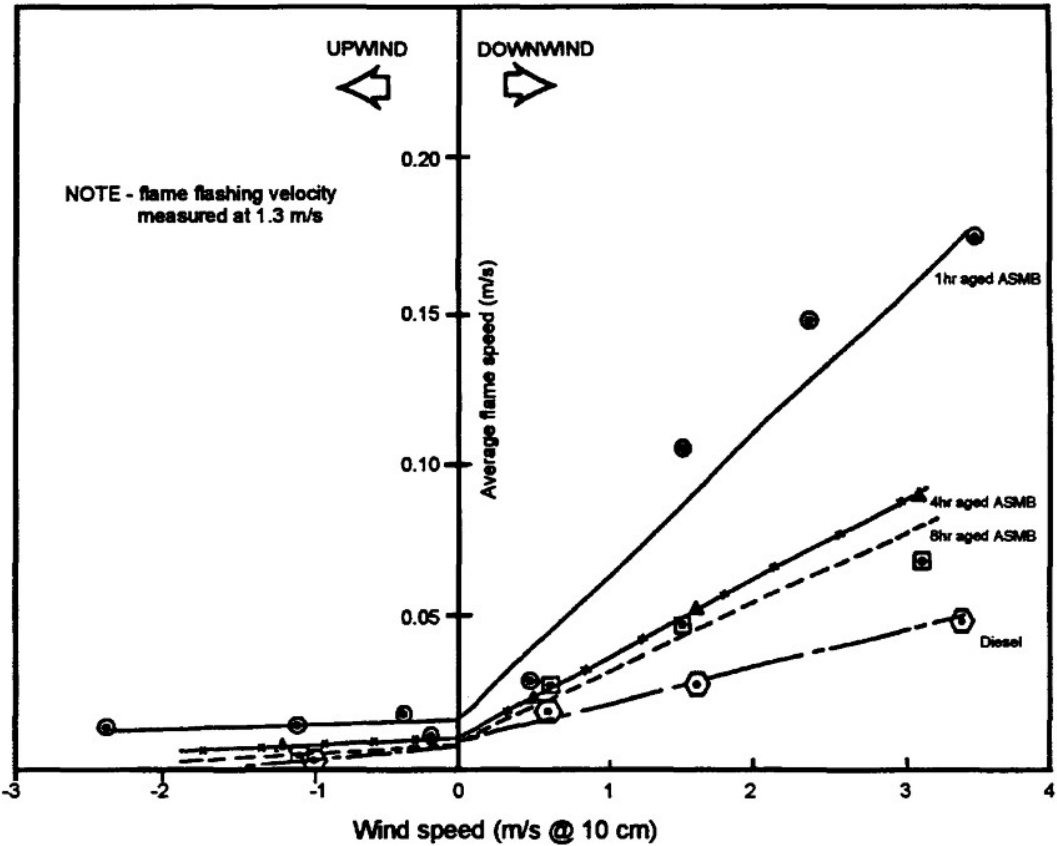

Figure 4-13 Flame spreading velocity. (Source: Marine Spill Response Corporation)

The data show that downwind spreading increases with increasing wind speed. This is due to bending of the flame by the wind enhancing radiative heat transfer to the slick (Energetex, 1981). The flame velocity is also dependent on oil volatility.

The data in [Figure 4-13](#) show that flame spreading upwind is slow but measurable. This spreading must be due to surface-tension-driven flow as radiative heat transfer on the upwind side of the flame would be very low. SL Ross & Energetex (1986) developed a simple model to reflect these effects on sub-flash flame spreading velocity. They based the oil volatility term on the initial boiling point of the crude rather than flash point, because flash point results vary greatly with the method and apparatus employed (Murty, 1988). The model is:

- for upwind flame spreading

$$U_{F,U} = 1.3 \exp(-7.88 ((T_B - T_A)/T_B)^{0.19}) \tag{4-6}$$

where the term 1.3 is the flame flashing velocity in quiescent conditions:

- for downwind flame spreading

$$U_{F,d} = U_{F,U} + u \exp(-6.52 ((T_B - T_A)/T_B)^{0.23}) \tag{4-7}$$

Where:

$U_{F,u}; U_{F,d}$	= upwind and downwind flame spreading velocities (m/s)
u	= wind speed (m/s)
T_B	= initial boiling point of the oil (as measured by ASTM D87 distillation)
[°K]	
T_A	= temperature of oil slick [°K]

Data from Smith & Diaz (1987) indicate an upwind flame spreading velocity of 0.04 m/s for fresh Prudhoe Bay crude and 0.025 m/s for weathered crude against 4 to 7 m/s winds. For crosswind flame spreading the upwind flame velocity is used. This is consistent with the observation that, in windy conditions, flames spread nearly straight downwind from an ignition point without much crosswind spread (e.g., Energetex, 1981; Dome, 1981). Data reported in Bech *et al.* (1992) for downwind flame spreading velocities over slicks of weathered crude oil show a trend in declining spreading velocity with increased weathering.

It has been observed numerous times in the field that, although flame spreads slowly upwind or crosswind, the presence of a barrier or edge that provides a wind break can permit rapid upwind or cross-wind spreading.

Currents and regular waves (or swell) do not seem to affect flame spreading for unemulsified oils, but choppy or steep waves have been noted to curtail flame spreading (Energetex, 1981; Dome, 1980; Bech *et al.*, 1993).

4.6 Flame Heights and External Radiation

Flames from in situ burning of oil on water are characterized as diffusion flames (in which oxygen must diffuse into the combustion zone) with yellow or orange colour and smoke production (as opposed to blue, premixed flames where the correct amount of oxygen is already present in the combustion zone). For the size range of interest for in situ burning (>1-m diameter) the flames can be considered as turbulent. The inadequately aerated (i.e., oxygen-poor) nature of in situ burning of large oil slicks results in the obscuration of the flames by the thick, black smoke produced. This often makes it difficult to estimate flame heights for these fires.

Furthermore, large pool-fire flames are known to oscillate in height at a predictable frequency. Evans *et al.* (1992) have correlated in situ burning flame pulsation data for 2 to 17-m diameter crude oil fires on water with Pagni's (1991) equation:

$$f = 1.5/D^{1/2} \quad (4-8)$$

where:

f	= pulsation frequency [Hz]
D	= diameter of fire [m]

The results of Evans *et al.* (1992) indicate little effect of wind speed on pulsation frequency.

The best available data set on flame heights of large-diameter hydrocarbon fires is that of Blinov and Khudiakov (1959) shown in [Figure 4-14](#). Also shown on [Figure 4-14](#) are the data of Gostintsev *et al.* (1984); data from photographs contained in McAllister & Buist (1981), SL Ross & Energetex (1987), SINTEF & SL Ross (1993); estimates based on thermography from Koseki (1993) and reported flame heights from a test burn after the *Exxon Valdez* spill (Allen, 1991). It

should be noted that it is extremely difficult to visually estimate flame heights and particularly so from photography; it is likely that such flame height estimates are only accurate to within $\pm 50\%$. Another complicating factor is that all of the above-noted larger burns occurred outdoors in some wind, which will bend flames and affect flame heights.

McCaffrey (1988) recommends the following equation of Heskestad (1983) to estimate flame heights of pool fires:

$$\frac{H}{D} = 3.7 Q^{*0.4} - 1.02 \quad (4-9)$$

where:

H = flame height [m]
 D = diameter of burning slick [m]

And, for pool fires of hydrocarbons

$$Q^* = Q / (\rho_{\infty} C_p T_{\infty} g^{\frac{1}{2}} D^{\frac{5}{2}}) \quad (4-10)$$

where:

Q^* = dimensionless heat release rate, or fire Froude Number
 \dot{Q} = heat release rate [kW]
 ρ_{∞} = density of ambient air [kg/m³]
 C_p = heat capacity of ambient air [kJ/kg^oK]
 T_{∞} = absolute temperature of ambient air [K]
 g = acceleration of gravity [m/s²]

McCaffrey (1988) recommends the use of:

$$Q^* = \dot{Q} / (1110 D^{\frac{5}{2}}) \quad (4-11)$$

where:

$$\dot{Q} = \dot{m} \Delta H \quad (4-12)$$

where:

\dot{m} = mass burning rate [kg/s]
 ΔH = net heat of combustion of fuel [kJ/kg]

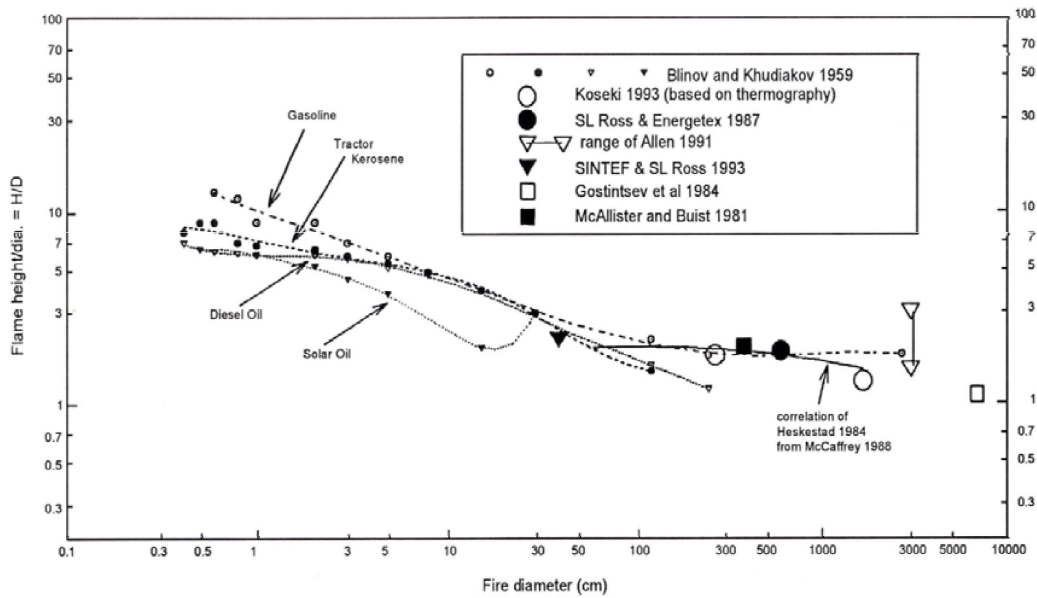

Figure 4-14 Flame height vs. fire diameter - a comparison of data sets. (Source: Marine Spill Response Corporation)

Data from Evans *et al.* (1992) and Walton *et al.* (1993) indicate the following dependence of Q (for steady state burning) on D for crude oil fires:

Table 4-3: Dependence of Q on D for crude oil fires			
D (m)	Q (kW)	Q^*	H/D
0.6	180	0.58	1.96
2.0	4000	0.64	2.07
6.9	82,000	0.59	1.98
17.2	500,000	0.37	1.46

At smaller fire diameters, (0.6 to 7-m) H/D is almost constant at 2; this coincides with the "rule-of-thumb" that fire heights are twice the fire diameter. At greater fire diameters, the ratio declines, as predicted by **equation 4-9** (see also **Figure 4-14**). Data from Gostintsev *et al.* (1984) indicates that the ratio of flame height to fire diameter approaches one as the fire diameter approaches 100 m.

One characteristic of the vigorous burning phase is an apparent increase in flame height compared with steady-state burning. Evans *et al.* (1992) and Walton *et al.* (1993) give the increase in heat release rate during vigorous burning. This increase, as a function of flame diameter, and the corresponding increase in flame height are:

Table 4-4: Height increases during vigorous burn phase			
D(m)	Q_{vig}/Q_{SS}	H/D	% increase in height over steady state burning
0.6	1.95	2.865	47%
2.0	1.76	2.88	64%
12	1.25	2.21	77%
17	1.34	1.80	34%

As shown, flame heights during vigorous burning can be expected to be greater than the steady state height. This is consistent with anecdotal reports of in situ burns in quiescent conditions. It should be noted again that the onset of a vigorous burn phase has never been observed in a towed fire boom (i.e., at the *Exxon Valdez* test burn, the DWH burns, or any experimental burn in a towed fire boom) or a burn in currents, likely because water flow under the burning slick prevents the water from heating enough to boil.

Wind is the predominant environmental factor that affects flames. The primary effect is to deflect the flame from vertical. Mudan & Croce (1988) give two correlations for the effect of wind speed on flame length; Thomas's (1963) correlation for wood crib fires shows a dependence of wind speed to the -0.2 power and Moorhouse's (1982) correlation for pool fires shows a -0.044 power dependence. Thomas's (1963) correlation would indicate a 50% increase in flame height (i.e., length) with an increase in wind from 1 to 10 m/s. Moorhouse's correlation would predict only a 10% change in flame length with a similar wind speed increase. These increases are within the accuracy of flame height measurements because of flame pulsation.

Brzustowski & Twardus (1982) use the dimensional equation of Pipkin & Sliepcevich (1964) to estimate flame deflection angle as a function of wind speed:

$$\tan\delta/(\cos\delta)^{\frac{1}{2}} = 7.72F_r \quad (4-13)$$

where:

- δ = deflection angle from vertical [degrees]
- F_r = kinematic Froude number = u^2/gD
- u = wind speed [m/s]

The solution to this equation is shown in [Figure 4-15](#). For a 17-m diameter fire in a 4 m/s wind ($F_r = 0.096$) a flame deflection angle of 30° from vertical would be predicted; this is broadly consistent with thermographs presented by Koseki for a crude oil fire under similar conditions. SINTEF & SL Ross (1993) report nearly horizontal flames for a 3-m x 1-m fire ($D = 2$ -m) in a 10 m/s wind ($F_r = 5.0$); [equation 4.15](#) predicts a deflection angle of about 70° . Mudan & Croce (1988) recommend the American Gas Association correlation for hydrocarbon pool fires, which, for larger crude oil burns, can be written as:

$$\cos\delta = 1.1 D^{1/6}/u^{1/2} \text{ for } D \text{ in [m] and } u \text{ in [m/s]} \quad (4-14)$$

This equation predicts a deflection angle of 25° for a 17-m diameter fire in 4 m/s winds and a 70° deflection for a 2-m diameter burn in 10 m/s winds.

The amount of heat radiated by the flame and smoke to external surfaces is a function of a number of variables and its theoretical derivation can be very complex (e.g., Tien *et al.*, 1988). Shokri & Beyler (1989) have developed a convenient engineering expression based on measured data for large pool fires. Their correlation, which is valid only for vertical targets at ground level, is:

$$\dot{q}'' = 15.4 (L/D)^{-1.59} \quad (4-15)$$

where:

- \dot{q}'' = incident heat flux [kW/m²]
- L = distance from pool center to target [m]

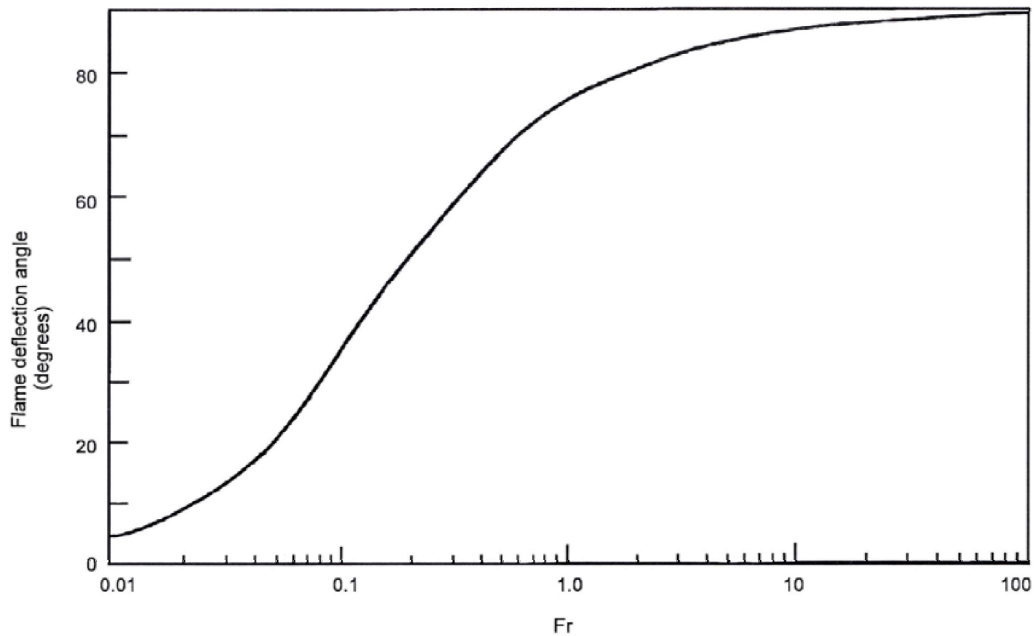

Figure 4-15 Flame deflection angle as a function of the kinematic Froude number, from Eq. 4-13 (from Brzustowski & Twardus, 1982). (Source: Marine Spill Response Corporation)

Figure 4-16 shows a comparison of this correlation with some experimental in situ burning measurements; though far from perfect, the fit is acceptable for estimation purposes. The increase (almost a doubling) in radiation associated with the vigorous burning phase is apparent in the data of Wakamiya *et al.* (1982) as shown in **Figure 4-16**. It is also worthy to note that Koseki (1993) has measured a considerable decrease in heat flux from crude oil fires at large fire

diameters; he postulates that this is due to increased flame radiation blockage by soot particles in larger fires.

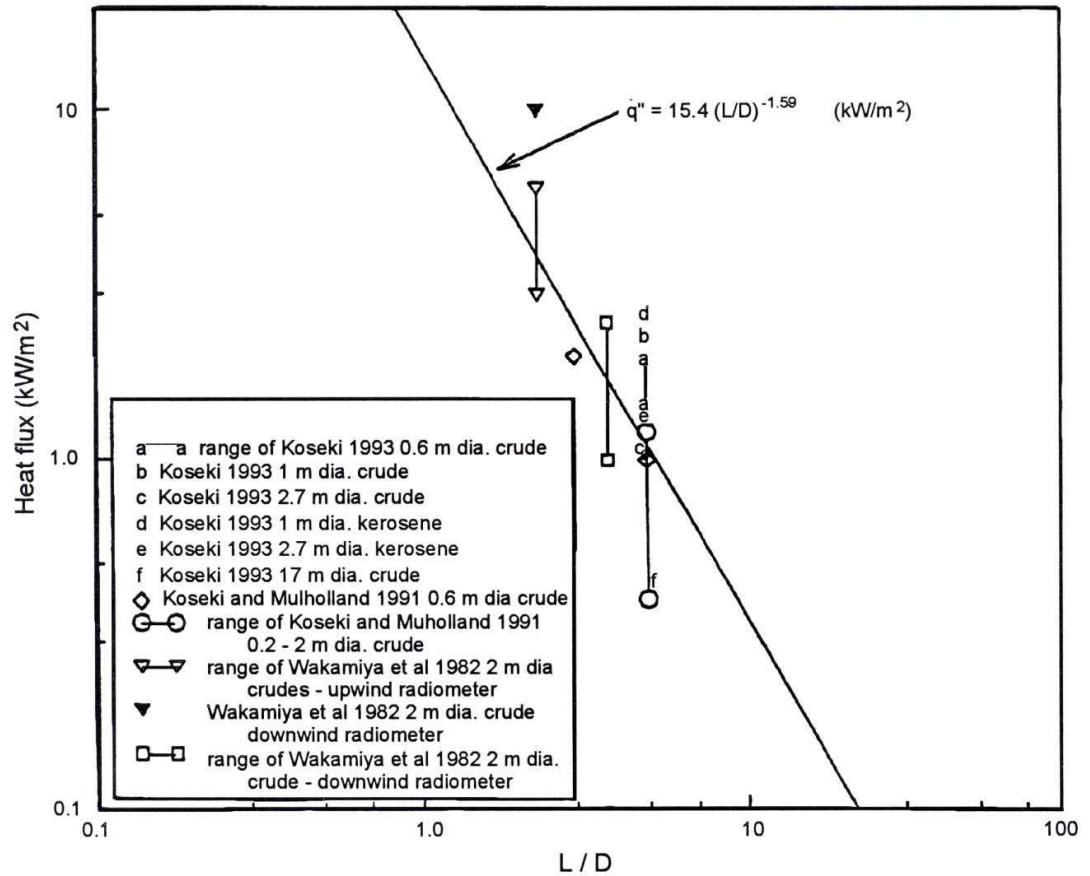

Figure 4-16 External heat flux from burning - comparison of Shokri & Beyler's (1989) correlation with in situ burn data. (Source: Marine Spill Response Corporation)

4.7 Safe Distance from Oil Flame

Equation 4-15 above can be used to estimate the safe distance for response personnel to keep from the flame of a burning pool of oil. Figure 4-17 shows a number of data sets correlating heat flux from fires to exposure times for uncovered skin of personnel. The limits for infinite exposure are in the range of 1.7 kW/m² (Mudan & Croce, 1988; Brzustowski & Sommer, 1973; Atallah & Allen, 1961). Substituting this into equation 4-15 above yields L/D = 4. This means that the safe approach distance

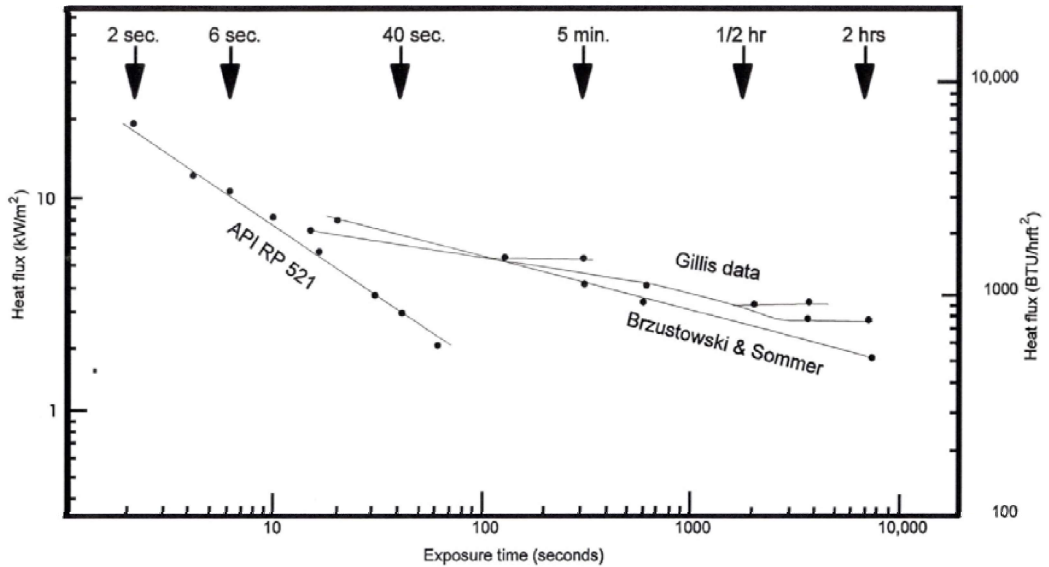

Figure 4-17 Allowable fluxes for personnel exposure (adapted from Oenbring & Sifferman, 1980). (Source: Marine Spill Response Corporation)

is 3.5 pool diameters from the edge of the fire. This is quite conservative as it does not take into account the effects of clothing and wind cooling on the heat flux. If personnel are exposed to bright sunlight in addition to fire radiation, the contribution of sunlight (1 kW/m²) should be taken into account.

Closer approaches can be made to the edge of the fire for short periods of time. [Table 4-5](#) below summarizes calculated safe approach distance (measured in fire diameters) to in situ burns for various exposure times.

Table 4-5: Calculated Safe Approach Distance to In Situ Oil Fire	
Exposure Time (min)	Safe Approach Distance for Personnel (fire diameters)
infinite	4
1/2 hour	3
5 minutes	2

Radiant heat fluxes necessary to cause charring and ignition of wood are on the order of 10 to 20 kW/m²; these heat fluxes would be experienced within one diameter of the center of the fire (0.5 diameters from the edge).

4.8 Effects of Emulsification

Many experiments on in situ burning of emulsions have been conducted over the past 40 years (Maybourn, 1971; Energetex, 1980; Hossain & Mackay, 1981; Energetex, 1981; Dome, 1982; SL Ross, 1989). In the last twenty years, the research has intensified and become more focused (Bech *et al.*, 1992 and 1993; Cabioc'h, 1993; SINTEF & SL Ross, 1993; Putorti & Evans, 1994; Guénette & Sveum, 1995; SL Ross, 1995; Guénette & Wighus, 1996; Walavalkar & Kulkarni, 1997; SL Ross, 1998; McCourt *et al.*, 2000; Walavalkar & Kulkarni, 2000 and 2001; Garo *et al.*, 2004; Brandvik *et al.*, 2010; Fritt-Rasmussen *et al.*, 2010; Fritt-Rasmussen & Brandvik, 2011).

In situ burning of water-in-oil emulsions likely involves several different processes as compared with the burning of unemulsified oils. The key differences relate to the heat and mass transfer processes involved. It has been postulated (Bech *et al.*, 1992 and 1993; Guénette *et al.*, 1994; SL Ross, 1995; Walavalkar & Kulkarni, 1997; Garo *et al.*, 2004; Walavalkar & Kulkarni, 2000 and 2001) that ignition and burning of emulsions involves a two-step process: breaking the emulsion to form a layer of oil laying on top of the slick; and subsequent combustion of this oil layer. Rate controlling processes for this model of emulsion burning may include: the rate of emulsion breaking; evaporation of emulsion water; external heat flux; and, heat conduction through the emulsion slick. It is clear that emulsion stability at elevated temperatures plays a key role in defining whether or not a particular emulsion slick is burnable.

The rate of oil removal by burning declines with increasing emulsion water content. Data from SL Ross (1989) indicate that an increase in water content from 0 to 25% by volume reduces oil burn rates by 1/3 to 1/2 for oils that form stable emulsions. Increasing the water content further to 50% by volume further reduces the oil removal rate by a total of 1/2 to 1 (i.e., no burning). A general "rule-of-thumb" appears to be that the rate of oil (not emulsion) removal by burning is proportional to the fraction of oil in the emulsion. Data from Energetex (1980), Bech *et al.* (1992), Cabioc'h (1993), Guénette *et al.* (1994), SL Ross (1995), Walavalkar & Kulkarni (2000) and Garo *et al.* (2004) support this general trend. The decrease in burning rate with increasing water content is accentuated by evaporation of the oil.

Based on a variety of experimental crude oil emulsion burns on water 0.4-m to 9.5-m in diameter, **Equation 4-2** can be modified to incorporate the effects of emulsion water content (for ignitable emulsion *in situ* burns up to \approx 50 to 60% water content):

$$\dot{r}'' \cong 3.5 \left(1 - \frac{\%H_2O}{100} \right) \left(1 - e^{-\frac{-D}{100}} \right) \quad (4-16)$$

where:

- \dot{r}'' \equiv oil burn regression rate [mm/min]
- $\%H_2O$ \equiv water content of emulsion [% volume]
- D \equiv diameter of burn (cm)

For burns > 3.5-m in diameter (i.e., most burns in fire booms) this can be rewritten as:

$$\dot{r}'' \cong 3.5 \left(1 - \frac{\%H_2O}{100} \right) \quad (4-17)$$

Emulsion Water Content [%]	Predicted Oil Burn Rate for <i>In situ</i> Fire > 3.5-m diameter [mm/min]
0	3.5
10	3.0
25	2.5
50	2.0

* Likely accuracy is $\pm 20\%$

It should be noted that the in situ burning of some oils that form emulsions does not appear to be as greatly affected by water content as noted above. Some researchers believe that perhaps high wax content, low asphaltene content oils fall into this category (Energetex, 1980; SL Ross, 1989; Guénette et al., 1994; McCourt et al., 2000; Fritt-Rasmussen et al., 2011). The reason that emulsions of these oils are more burnable may relate to the instability of the emulsion at elevated temperatures (below 100°C). It is theorized that although emulsions stable at elevated temperatures can only burn as fast as the emulsified water is evaporated, emulsions that break spontaneously at elevated temperatures can physically release water-free oil for burning, and thus allow burning to proceed at a faster rate.

The results of experiments performed by SL Ross (1989), Bech *et al.* (1992), Bech *et al.* (1993), Cabioc'h (1993), and Guénette *et al.* (1994) all show similar trends that led to the following rules of thumb:

Rules of Thumb for the Effects of Emulsification

- Little effect on oil removal efficiency (i.e., residue thickness) for low water contents up to about 12.5% by volume;
- A noticeable decrease in burn efficiency with water contents above 12.5%, the decrease being more pronounced with weathered oils; and
- Zero burn efficiency for emulsion slicks having stable water contents of 25% or more. Some crudes form meso-stable emulsions that can be burned efficiently at much higher water contents. Paraffinic crudes appear to fall into this category.

In situ burning of higher water content emulsions can involve vigorous burning (with its characteristic droplet production and more violent burning) throughout the entire burn (Energetex, 1980; SL Ross, 1989; Garo *et al.*, 2004). This relates to the superheating and boiling of emulsion water from within the slick. The vigorous stage of burning, just prior to extinction, also may be enhanced for emulsions; this possibly relates to enhanced heat transfer through an emulsion slick as opposed to a pure oil slick. As noted above, the vigorous burn phase is not always observed.

The residue remaining after an emulsion burn generally increases with increasing water content, depending on the stability of the emulsion. Data from Energetex (1980), SL Ross (1995), SL Ross (1998), and Guénette *et al.* (1994) indicate little change in residue amount for oils not forming very stable emulsions; however, for oils that did form stable emulsions the residue was two to three times as thick as unemulsified slicks. The water content of the residue was not reported.

Sometimes, extinction of emulsions is initiated by foaming action of the burning slick (Energetex, 1980; SL Ross, 1989; Guénette *et al.*, 1994; SL Ross, 1995; Garo *et al.*, 2004). The foaming is presumably associated with boiling of water, but its origin and contributing factors are unclear. It is not unusual for a burning emulsion slick to foam over one area of its surface while another is still burning; as the foam breaks, the extinguished surface is re-ignited by adjacent flames. This process can result in sudden and rapid flare-ups of flame during an emulsion burn (SL Ross, 1995).

Emulsion slick in situ combustion, perhaps because of the more complex and likely delicate heat balance, seems to be more sensitive to environmental conditions than unemulsified slicks. Bech *et al.* (1993) report that regular wave action resulted in a considerable reduction in burn efficiency (from 80% to 50%) for a weathered, 25% water emulsion. Waves did not have a similar effect when burning an unemulsified slick of the same oil (removal efficiency = 90%). Energetex (1981) indicates that the burning of stable 50% water emulsions of weathered crude was far more sensitive than unemulsified oils to wind effects.

Ignition of emulsions is more difficult than ignition of unemulsified oil; subsequent flame spreading over emulsion is also slower. Energetex (1980) indicates that the fire point of water-in-oil emulsions increased with increasing water content (Figure 4-18). The fire point of fresh oils that formed highly stable emulsions rose rapidly above 30% water content; oils that form less stable emulsions had less dramatic increases. Smith & Diaz (1987) and Guénette *et al.* (1994) also observed an increase in fire point with emulsification. Many researchers (Energetex, 1980; Hossain & Mackay, 1981; Dome, 1982; SL Ross, 1989; Guénette *et al.*, 1994; SL Ross, 1995; SL Ross, 1998; McCourt *et al.*, 2000; Walavalkar & Kulkarni, 2000 and 2001; Garo *et al.*, 2004; Brandvik *et al.*, 2010; Fritt-Rasmussen, 2010; Fritt-Rasmussen *et al.*, 2011) have noted that ignition of emulsions *in situ* becomes more difficult with increasing water content. Energetex (1980) noted that, for stable emulsions with water contents in excess of 40%, a layer of fresh crude oil spread over the surface of the emulsion was necessary for successful ignition. In essence, the added crude oil was acting as a flame spread promoter. Other experience has shown ignition of emulsion slicks in ice melt pools could not be accomplished with gasoline-soaked sorbents; diesel-soaked sorbents were required, as was priming the slick with diesel (Dome, 1982). SL Ross (1989 and 1995) noted that, as water content increased, successively stronger ignition sources were required.

This trend was further explored by Bech *et al.* (1992) who ranked ignition sources in increasing order of strength as: gelled gasoline, gelled diesel, and gelled crude oil. They postulated that the success of the stronger igniters rested with higher flame temperatures (and thus increased radiant heat). Cabioc'h (1993) concluded that gelled diesel was an effective igniter for emulsions. Guénette *et al.* (1994) concluded that gelled fresh crude was a better igniter for emulsions than gelled gasoline. Walavalkar & Kulkarni (1997), in their mathematical models of the three stages of emulsion burning (first, initial heating of the slick, second, ignition of the oil layer and breaking the underlying emulsion, and third, steady combustion) predicted that increased heat flux to the surface of an emulsion (i.e., increased igniter power) will result in

faster ignition. They later performed laboratory experiments to confirm this and quantify the required heat flux (Walavalkar & Kulkarni, 2000 and 2001). Wu *et al.* (1997) performed a similar series of experiments with emulsions in a standard ASTM flame spreading apparatus.

The maximum ignitable water content of an emulsion seems to be controlled by three factors:

- Degree of weathering of the parent oil (more evaporated emulsions are more difficult to ignite);
- Stability of the emulsion at temperatures less than 100°C (Cabioc'h, 1993 postulates that high asphaltene emulsions are more difficult to ignite); and,
- Strength of the igniter.

The maximum ignitable water content for oils has ranged from 10% to 70% (Energetex, 1980; SL Ross, 1989; Bech *et al.*, 1992; Cabioc'h, 1993; Guénette *et al.*, 1994; SL Ross, 1997; Fritt-Rasmussen *et al.*, 2011). Guénette *et al.* (1994) showed that emulsions with water contents as high as 50%, when herded into a contained oil slick fire by current and wind action, would ignite and burn efficiently.

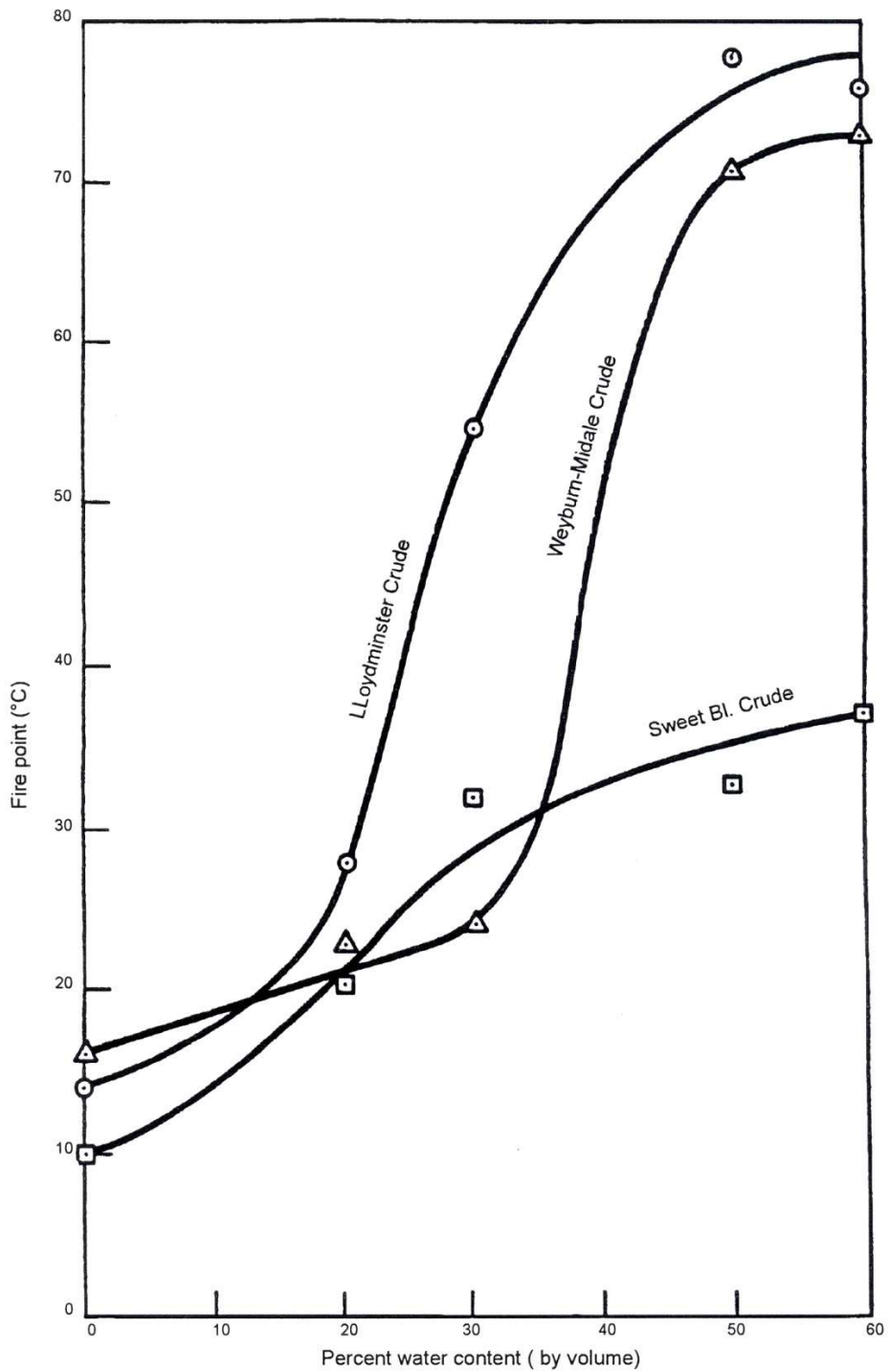

Figure 4-18 W/O emulsion fire points vs. water content (from Energetex 1980). (Source: Marine Spill Response Corporation)

Not only are water-in-oil emulsions difficult to ignite, flame spreading over their surface is much slower. Energetex (1980 and 1981), Hossain & Mackay (1981), Smith & Diaz (1987), SL Ross (1989), Allen (1991), Bech *et al.* (1992), Guénette *et al.* (1994), SL Ross (1995 and 1997) and Wu *et al.* (1997) have all noted significant reductions in flame spreading rates with increasing water content. This is likely due to a combination of the following factors:

- Increased slick viscosity, slowing interfacial-tension-induced flow and flame spreading;
- Increased heat transfer by conduction through the emulsified slick;
- Increased flash/fire points of the emulsified slick; and
- Delays due to the need to break the emulsion and form a layer of water-free oil for the flame to propagate across.

Bech *et al.* (1993) have noted that flame spreading over emulsions is very sensitive to wave action; even regular, swell-type waves prevented ignition and flame spreading over heavily weathered, 25% water emulsions. Energetex (1981) concluded that flame spreading over emulsions is more sensitive to wind influences than unemulsified oils. Bech *et al.* (1993) and Guénette *et al.* (1994) gave the maximum wind speed for burning emulsions as 36 km/h (20 knots). SL Ross (1995) confirmed this.

Flame heights for emulsion burns in quiescent conditions tend to be higher than for unemulsified oils (SL Ross, 1989; SINTEF & SL Ross, 1993); this is believed to be related to micro-explosions (Twardus & Brzustowski, 1981) in the slick ejecting oil droplets into the flame (in a manner similar to the vigorous burning phase at the end of an in situ burn of unemulsified oil on water). Although no data on radiant heat fluxes from emulsion fires could be found, anecdotal accounts exist of emulsion fires being "warmer" than unemulsified oils. This may be a result of suppressed soot production due to the presence of the water or due to increased flame heights (the rate of oil consumption for emulsions is less than that for unemulsified oil; thus an increased combustion rate cannot be a reason).

4.8.1 A Model for Emulsion Burning

Several conceptual models for the processes involved with in situ burning of emulsions have been proposed (e.g., Guénette *et al.*, 1994; Walavalkar & Kulkarni, 1997). A detailed description of these is beyond the scope of this report. Walavalkar & Kulkarni (1997) give an excellent review of the subject. The basic premise of their conceptual model of emulsion slick burning is based on the postulation by Bech *et al.* (1992 and 1993) that it is not the emulsion itself that burns, but a layer of oil floating on the emulsion that supports combustion.

This is illustrated in **Figure 4-19**. Heat radiated back to the slick from the flame must both: warm and vaporise the surface oil layer; and, provide energy for the production of an oil layer from the underlying emulsion. The layer of oil can be generated in two ways: by boiling off the water contained within the emulsion or by physically breaking the emulsion by heating. It is possible that both these water-removal processes are occurring simultaneously. If an emulsion that is very stable at temperatures up to 100°C (the boiling point of water) is to burn, then boiling of emulsion water would be the only removal process and would be the rate-limiting process; if the emulsion is unstable and breaks easily at elevated temperatures (less than 100°C) the rate at which oil separates out of the emulsion would be the limiting rate (i.e., the oil cannot vaporise and burn faster than the rate at which an oil layer is produced from the breaking emulsion). Guénette *et al.* (1994) postulate that, because the viscosity of the underlying slick is high, the water physically separating from the emulsion cannot settle out and they conclude

that the major water removal process is vaporization or boiling of the water. Evidence from their laboratory tests, and others (SL Ross, 1995; Walavalkar & Kulkarni, 1997), suggests that the separated water may be accumulated interstitially within the slick until the bottom

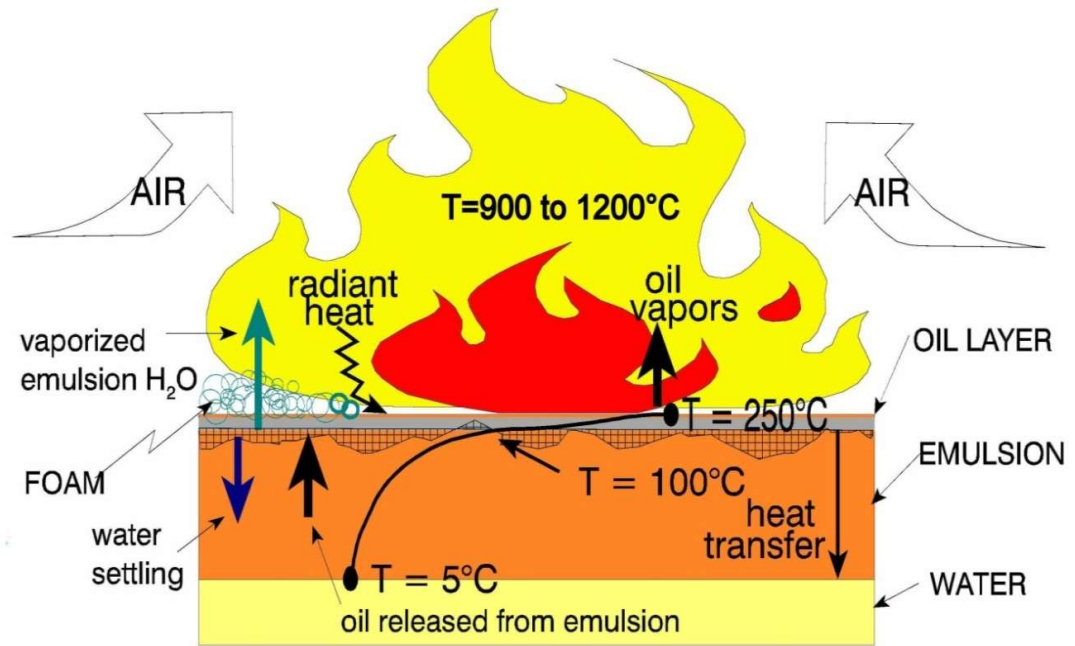

Figure 4-19 Key heat and mass transfer processes for in situ burning of emulsions. (Source: SL Ross Environmental Research)

interface of the slick is fluid enough to allow the water to pass through. It is the release of the oil to the surface of the slick that is crucial to sustained emulsion burning; the water does not have to exit the slick immediately for this to happen.

Foaming of a burning emulsion may also be related to the water loss mechanism (boiling vs. breaking), the rate of breaking and the presence of film-stabilizing chemical species in the oil. Foam is created by the intense mixing of a gas and liquid. The liquid contains surface acting chemicals that stabilise a thin film of liquid around the gas bubble. In the case of burning emulsions that foam, the gas is likely steam and the liquid is likely oil (it is probably not emulsion since the ambient temperatures would quickly boil any water).

When foam is generated it extinguishes the fire locally by either smothering, insulating the oil layer, or a combination of the two. After the foam breaks, if another area of the slick is still on fire, the affected area can reignite and burn. This was demonstrated during one large-scale emulsion burn reported by SL Ross (1995).

References to Chapter 4

- Akita, K. and T. Yumoto. 1965. **Heat transfer in small pools and rates of burning of liquid methanol.** In: *Proceedings of the Tenth Symposium (International) on Combustion*. The Combustion Institute, Pittsburgh, PA, pp. 943-948.
- Akita, K. 1972. **Some problems of flame spread along a liquid surface.** In: *Proceedings of the Fourteenth Symposium (International) on Combustion*. The Combustion Institute, Pittsburgh, PA, pp. 1075-1083.
- Allen, A.A. 1986. **Alaska Clean Seas Survey and Analysis of Air-Deployable Igniters.** In: *Proceedings of the Ninth Arctic and Marine Oilspill Program (AMOP) Technical Seminar*, June 10-12, Edmonton, AB. Environment Canada, Ottawa, ON, Canada, pp. 353-373.
- Allen, A.A. 1987. **Refinement of Aerial Ignition Systems, (Test and Evaluation of the Heli-Torch for the Ignition of Oil Slicks).** Report to Alaska Clean Seas, Anchorage, AK, U.S.
- Allen, A.A. 1991. **Controlled Burning of Crude Oil on Water Following the Grounding of the Exxon Valdez.** In: *Proceedings of the 1991 Oil Spill Conference*, March 4-7, San Diego, CA. American Petroleum Institute, Washington, DC, U.S., pp. 213-216.
- Atallah, S. and D.S. Allan. 1961. **Safe Separation Distances from Liquid Fuel Fires.** *Fire Technology*, 7(1):47-56.
- Babrauskas, V. 1988. **Burning Rates.** *The SFPE Handbook of Fire Protection Engineering*, 1988 Edition, pp. 2.1-2.15.
- Battelle. 1979. **Combustion: an Oil Spill Mitigation Tool.** Report for U.S. Department of Energy, Contract No. EY-76-C-Q6-1830, U.S. Department of Energy, Washington, DC, U.S.
- Bech, C., P. Sveum, and I.A. Buist. 1992. **In Situ Burning of Emulsions: the Effects of Varying Water Content and Degree of Evaporation.** In: *Proceedings of the Fifteenth Arctic and Marine Oilspill Program (AMOP) Technical Seminar*, June 10-12, Edmonton, AB. Environment Canada, Ottawa, ON, Canada, pp. 547-559.
- Bech, C., P. Sveum, and I. Buist. 1993. **The Effect of Wind, Ice and Waves on the In Situ Burning of Emulsions and Aged Oils.** In: *Proceedings of the Sixteenth Arctic and Marine Oilspill Program (AMOP) Technical Seminar*, June 7-9, Calgary, AB. Environment Canada, Ottawa, ON, Canada, pp. 735-748.
- Brandvik, P.J., J.L.M. Resby, P.S. Daling, F. Leirvik, and J. Fritt-Rasmussen. 2010. **Mesoscale Weathering of Oil as a Function of Ice Conditions: Oil Properties, Dispersability and In Situ Burnability of Weathered Oil as a Function of Time.** SINTEF Report No. 19, A15563.
- Blinov, V.I. and G.N. Khudiakov. 1959. **Certain Laws Governing Diffusive Burning of Liquids.** *Fire Research Abstracts and Review*. Vol 1(1), pp. 41-44.
- Brzustowski, T.A. and E.C. Sommer, Jr. 1973. **Predicting Radiant Heating from Flames.** Mid-Year Meeting of the American Petroleum Institute, Philadelphia, PA.
- Brzustowski, T.A. and E.M. Twardus. 1982. **A Study of the Burning of a Slick of Crude Oil on Water.** In: *Proceedings of the Nineteenth Symposium (International) on Combustion*. The Combustion Institute, Pittsburgh, PA, U.S., pp. 847-854.
- Buist, I.A. and L.R. McAllister. 1981. **Dome Petroleum's Fireproof Boom -Development and Testing to Date.** In: *Proceedings of the Fourth Arctic and Marine Oilspill Program (AMOP) Technical Seminar*, June 16-18, Edmonton, AB. Environment Canada, Ottawa, ON, Canada, pp. 479-497.
- Buist, I.A., N. Glover, B. McKenzie, and R. Ranger. 1995. **In Situ Burning of Alaska North Slope Emulsions.** In: *Proceedings of the 1995 Oil Spill Conference*, February 27 - March 2, Long Beach, CA. American Petroleum Institute, Washington, DC, U.S., pp. 139-146.
- Buist, I., T. Coe, D. Jensen, S. Potter, L. Anderson, K. Bitting, and K. Hansen. 2003. **In Situ Burn Operations Manual.** U.S. Coast Guard Research & Development Center Report CG-D-06-03, Groton, CT, U.S.
- Cabioc'h, F. 1993. **Last French Experiments in Order to Evaluate the Burning Possibilities of Three Water-In-Oil Emulsions.** In: *Proceedings of the Sixteenth Arctic and Marine Oilspill Program (AMOP) Technical Seminar*, June 7-9, Calgary, AB. Environment Canada, Ottawa, ON, Canada.

- Dome Petroleum Ltd. (Dome). 1981. **Fire Proof Boom Development -OHMSETT Trials**. Dome Petroleum Ltd., Calgary, AB, Canada, 27 p.
- Dome Petroleum Ltd. (Dome). 1982. **Fate and Behaviour of Water-In-Oil Emulsions in Ice**. Report to COOSRA. Calgary, AB, Canada, 55p.
- Energetex Engineering. 1977. **Ignition and Burning of Crude Oil on Water Pools and Under Arctic Spring Time Conditions**. Arctic Petroleum Operators Association (APOA) Project 141; Calgary, AB, Canada, 70p.
- Energetex Engineering (Energetex). 1978. **Testing of Air-Deployable Incendiary Devices for Igniting Oil On Water**. Environment Canada, Report No. EPS-4-EC-78-11; Ottawa, ON, Canada, 98 p.
- Energetex Engineering (Energetex). 1980. **A Study to Evaluate the Combustibility and Other Physical and Chemical Properties of Aged Oils and Emulsions**. Report to Environment Canada, Ottawa, ON, Canada..
- Energetex Engineering (Energetex). 1981. **Burning of Crude Oil under Wind Herding Conditions**. Report prepared for Canadian Marine Drilling Ltd.
- Evans, D., H. Baum, B. McCaffrey, G. Mulholland, M. Harkleroad, and W. Manders. 1986. **Combustion of Oil On Water**. In: *Proceedings of the Ninth Arctic and Marine Oilspill Program (AMOP) Technical Seminar*, June 10-12, Edmonton, AB. Environment Canada, Ottawa, ON, Canada, pp. 301-336.
- Evans, D., G. Mulholland, D. Gross, H. Baum, and K. Saito. 1987. **Environmental Effects of Oil Spill Combustion**. In: *Proceedings of the Tenth Arctic and Marine Oilspill Program (AMOP) Technical Seminar*, June 9-11, Edmonton, AB. Environment Canada, Ottawa, ON, Canada, pp. 91-130.
- Evans, D.D., G. Mulholland, D. Gross, H. Baum, and K. Saito. 1988. **Burning, Smoke Production, and Smoke Dispersion from Oil Spill Combustion**. In: *Proceedings of the Eleventh Arctic and Marine Oilspill Program (AMOP) Technical Seminar*, June 7-9, Vancouver, BC. Environment Canada, Ottawa, ON, Canada, pp. 41-87.
- Evans, D., W. Walton, H. Baum, K.A. Notarianni, J.R. Lawson, H.C. Tang, K.R. Keydel, R.G. Rehm, D. Madrzykowski, and R.H. Zile. 1992. **In Situ Burning of Oil Spills: Mesoscale Experiments**. In: *Proceedings of the Fifteenth Arctic and Marine Oilspill Program (AMOP) Technical Seminar*, June 10-12, Edmonton, AB. Environment Canada, Ottawa, ON, Canada, pp. 593-657.
- Fritt-Rasmussen, J. 2010. **In Situ Burning of Arctic Marine Oil Spills: Ignitability of Various Oil Types Weathered at Different Ice Conditions**. A combined laboratory and field study. Dissertation for the degree philosophiae doctor (PhD) at the Technical University of Denmark. DTU Civil Engineering Report R-229.
- Fritt-Rasmussen, J. and P.J. Brandvik. 2011. **Measuring Ignitability for In Situ Burning of Oil Spills Weathered under Arctic Conditions: from Laboratory Studies to Large-Scale Field Experiments**. *Marine Pol. Bul.*, 62(8):1780-1785.
- Fritt-Rasmussen, J., B.E. Ascenius, P.J. Brandvik, A. Villumsen, and E.H. Stenby. 2013. **Composition of In Situ Burn Residue as a Function of Weathering Conditions**. *Marine Pollution Bulletin*, 15;67(1-2):77-81.
- Garo, J.P., J.P. Vantelon, and C. Fernandez-Pello. 1994. **Boilover Burning of Oil Spilled on Water**. In: *Proceedings of the Twenty-Fifth Symposium (International) on Combustion*, The Combustion Institute, Pittsburgh, PA, U.S., pp. 1481-1488.
- Garo, J.P., J.P. Vantelon, S. Gandhi, and J.L. Torero. 1999. **Determination of the Thermal Efficiency of Pre-boilover Burning of a Slick of Oil on Water**. *Spill Science & Technology Bulletin*, 5(2):141-151.
- Garo, J.P., J.P. Vantelon, J.M. Souil, and C. Breillat. 2004. **Burning of Weathering and Emulsified Oil Spills**. *Experimental Thermal and Fluid Science*, 28 (2004):753-761.
- Garo, J.P., H. Koseki, J.P. Vantelon, and C. Fernandez-Pello. 2007. **Combustion of Liquid Fuels Floating on Water**. *Thermal Science*: 11(2):119-140.
- Glassman, I. and J.G. Hansel. 1968. **Some Thoughts and Experiments on Liquid Fuel Spreading, Steady Burning and Ignitability**. *Fire Research Abstracts and Reviews* 10(3):217-234.

- Glassman, I., J.G. Hansel, and T. Eklund. 1969. **Hydrodynamic Effects in the Flame Spreading, Ignitability and Steady Burning of Liquid Fuels.** *Combustion and Flame*, 13:99-101.
- Gostintsev, Y.A., N.P. Kopylov, V.V. Lararev, M.A. Motin, Y.V. Shatskikh, and A.F. Solodovnik. 1984. **Burning of Petroleum on the Surface of Water (Large Scale Experiment).** *Combustion, Explosion and Shock Waves*, 19(4):401-404.
- Guénette, C.C., P. Sveum, I. Buist, T. Aunaas, and L. Godal. 1994. **In Situ Burning of Water-In-Oil Emulsions.** SINTEF Report STF21 A94053. SINTEF Applied Chemistry, Trondheim, Norway, 139 p.
- Guénette, C.C. and P. Sveum. 1995. **In Situ Burning of Emulsions R&D in Norway.** *Spill Sci. Technol. Bull.* 2(1):75-77.
- Guénette, C.C., P. Sveum, C. Bech, and I. Buist. 1995. **Studies of In Situ Burning of Emulsions in Norway.** In: *Proceedings of the 1995 Oil Spill Conference*, February 27 - March 2, Long Beach, CA. American Petroleum Institute, Washington, DC, U.S., pp. 115-122.
- Guénette, C.C. and R. Wighus. 1996. **In Situ Burning of Crude Oil and Emulsions in Broken Ice.** In: *Proceedings of the Arctic and Marine Oilspill Program (AMOP) Technical Seminar*, No. 19, Vol. 2, pp. 895-906. Environment Canada, Ottawa, ON, Canada.
- Hagglund, B. and L. Persson. 1976. **The Heat Radiation from Petroleum Fires.** FOA report C-20126-D6(A3) Stockholm, Sweden.
- Hall, A.R. 1973. **Pool Burning.** *Oxidation and Combustion Reviews*, 6:169-225.
- Heskestad, G. 1983. **Luminous Height of Turbulent Diffusion Flames.** *Fire Safety Journal*, Volume 5, pp. 103-108.
- Hossain, K. and D. MacKay. 1981. **A Study of the Combustibility of Weathered Crude Oils and Water-In-Oil Emulsions.** Environment Canada Report EE-12, Environment Canada, Ottawa, ON, Canada, 43 p.
- Kanury, A.M. 1988. **Ignition of Liquid Fuels.** *SFPE Handbook of Fire Protection Engineering*, National Fire Protection Association, Quincy, MA, U.S., pp. 1.315-1.325.
- Koseki, H. and G.W. Mulholland. 1991. **The Effect of Diameter on the Burning of Crude Oil Pool Fires.** *Fire Technology*, 27(1):54-65.
- Koseki, H. 1993. **Thermography Research for Radiation Measurement of an Oil Spill Fire.** In: *Proceedings of the Sixteenth Arctic and Marine Oilspill Program (AMOP) Technical Seminar*, June 7-9, Calgary, AB. Environment Canada, Ottawa, ON, Canada, pp. 833-842.
- Mackinven, R, J.G. Hansel, and I. Glassman. 1970. **Influence of Laboratory Parameters on Flame Spread across Liquid Fuels.** *Combustion Science and Technology*, 1(4):293-306.
- Maybourn, R. 1971. **The Work of the IP Working Group on the Burning of Oil.** *Journal of the Institute of Petroleum*, 57:12-16.
- McCaffrey, B.J. 1988. **Flame Height.** *The SFPE Handbook of Fire Protection Engineering*; National Fire Protection Association, Quincy, MA, U.S., pp. 1.298-1.305.
- McAllister, I.R. and I.A. Buist. 1981. **Dome Petroleum's Fireproof Boom - Development and Testing to Date.** In: *Proceedings of the Fourth Arctic Marine Oilspill Program (AMOP) Technical Seminar*, June 16-18, Edmonton, AB. Environment Canada, Ottawa, ON, Canada.
- McCourt, J., I. Buist, and S. Buffington. 2000. **Results of Laboratory Tests on the Potential for Using In-situ Burning on Seventeen Crude Oils.** In: *Proceedings of the Twenty-third Arctic Marine Oilspill Program (AMOP) Technical Seminar*, Environment Canada, Ottawa, ON, Canada, pp. 917-922.
- Moorhouse, J. 1982. **Scaling Criteria for Pool Fires Derived from Large-Scale Experiments.** *I. Chem. Sym.* 71. pp. 165-179.
- Mudan, K. and P. Croce. 1988. **Fire Hazard Calculations for Large Open Hydrocarbon Fires.** *SFPE Handbook of Fire Protection Engineering*; Nat. Fire Protection Association, Quincy, MA, U.S., pp. 2.45-2.87.
- Murad, R.J., J. Lamendola, H. Isoda, and M. Summerfield. 1970. **A Study of Some Factors Influencing the Ignition of a Liquid Fuel Pool.** *Combustion and Flame*, 15(3):289-298.

- Murty, K.A. 1988. **Ignition of Liquid Fuels**. *The SFPE Handbook of Fire Protection Engineering*; National Fire Protection Association, Quincy, MA, U.S., pp. 1.315-1.325.
- Oenbring, A.R. and T. R Sifferman. 1980. **Flare design are current methods too conservative? Hydrocarbon processing**. May 1980. pp. 124-129.
- OSIR (Oil Spill Intelligence Report). Published weekly by Cutter Information Corp. • 37 Broadway, Arlington, MA 02174-5539, U.S.
- Pagni, P.J. 1991. **Fire Modeling. Grant Report**. Summaries of BFRL Fire Research Program In-house Projects and Grants. National Institute of Standards and Technology (NIST), Gaithersburg, MD, U.S., pp. 57-60.
- Pipkin, O.A. and C.M. Sliepcevich. 1964. **Effect of Wind on Buoyant Diffusion Flames**. *Ind. & Eng. Chem. Fundamentals*, 3(2):147p.
- Putorti, A.D. and D.D. Evans. 1994. **Ignition of Weathered and Emulsified Oils**. In: *Proceedings of the 17th Arctic Marine Oilspill Program (AMOP) Technical Seminar*, June 8-10, Vancouver, BC. Environment Canada, Ottawa, ON, Canada, pp. 657-668.
- Shokri, M. and C.L. Beyler. 1989. **Radiation from Large Pool Fires**. *Journal of Fire Protection Engineering*, 1(4):141-150.
- SINTEF and S.L. Ross Environmental Research Ltd. (SL Ross). 1993. **In Situ Burning of Water-In-Oil Emulsions**. Report to NOFO et al., Stavanger, Norway.
- Sirignano, W.A. and I. Glassman. 1970. **Flame Spreading Above Liquid Fuels: Surface-Tension Driven Flows**. *Combustion Science and Technology*, 1:307-312.
- S.L. Ross Environmental Research Ltd. (SL Ross) and Energetex Engineering (Energetex). 1986. **In Situ Burning of Uncontained Oil Slicks**. EETD Report EE-60 revised. Environment Canada, Ottawa, ON, Canada.
- S.L. Ross Environmental Research Ltd. (SL Ross). 1989. **Disposal of Spilled Hibernia Crude Oils and Emulsions: In Situ Burning and the "Swirlfire" Burner**. Report to Canadian Coast Guard, Ottawa, ON, Canada.
- S.L. Ross Environmental Research Ltd. (SL Ross). 1995. **Demulsifiers and Modified Heli-Torch Fuels to Enhance In Situ Burning of Emulsions**. Report to ACS, Prudhoe Bay, AK, U.S.
- S.L. Ross Environmental Research Ltd. (SL Ross). 1997. **Laboratory Testing to Determine Operational Parameters for In Situ Burning of Six U.S. OCS Crude Oils**. Draft Report to the Minerals Management Service, Herndon, VA, U.S.
- S.L. Ross Environmental Research Ltd. (SL Ross). 1998. **The Efficacy of In Situ Burning for Alaskan Risk Oils**. Final Report to Alaska Clean Seas, Alaska Department of Environmental Conservation, AK and Minerals Management Service, Herndon, VA, U.S.
- Smith, N.K. and A. Diaz. 1985. **In-Place Burning of Crude Oil in Broken Ice -1985 Testing at OHMSETT**. In: *Proceedings of the Eighth Arctic and Marine Oilspill Program (AMOP) Technical Seminar*, June 18-20, Edmonton, AB. Environment Canada, Ottawa, ON, Canada, pp. 176-191.
- Smith, N.K. and A. Diaz. 1987. **In-Place Burning of Crude Oils in Broken Ice**. In: *Proceedings of the 1987 Oil Spill Conference*, April 6-9, Baltimore, MD. American Petroleum Institute, Washington, DC, U.S., pp. 383-387.
- Tam, W.K. and W.F. Purves. 1980. **Experimental Evaluation of Oil Spill Combustion Promoters**. In: *Proceedings of the Oceans '80 International Forum on Ocean Engineering in the 80's*. IEEE, Piscataway, NJ, U.S., pp. 415-421.
- Tien, C.L., K.Y. Lee, and A.J. Stretton. 1988. **Radiation Heat Transfer**. *The SFPE Handbook of Fire Protection Engineering*; National Fire Protection Association, Quincy, MA, U.S., pp. 1.92-1.105.
- Thomas, P.H. 1963. **The Size of Flames from Natural Fires**. In: *Proceedings of the Ninth Symposium (International) on Combustion*, Academic Press, New York, NY, U.S., pp. 844-859.
- Torrance, K.E. and R.L. Mahajan. 1974. **Fire spread over liquid fuels: liquid phase Parameters**. In: *Proceedings of the Fifteenth Symposium (International) on Combustion*. The Combustion Institute, Pittsburgh, PA, U.S., pp. 281-287.

- Torero, J.L., S. Olenick, J.P. Garo, and J.P. Vantelon. 2003. **Determination of the Burning Characteristics of a Slick of Oil on Water.** *Spill Science & Technology Bulletin*, 8(4):379–390.
- Twardus, E.M. and T.A. Brzustowski. 1981. **The Burning of Crude Oil Spilled On Water.** *Archivum Combustionis* 1(1/2):49-60.
- Wakamiya, W., S.E. Petty, A. Boiarski, and A. Putnam. 1982. **Combustion of Oils On Water: an Experimental Program.** U.S. Department of Energy Report No. NBM/1002. U.S. Department of Energy, Washington, DC, U.S., 95 p.
- Walavalkar, A. and A.K. Kulkarni. 1997. **A Mathematical Model for In Situ Burning of Water-In-Oil Emulsions.** In: *Proceedings of the 20th Arctic Marine Oilspill Program (AMOP) Technical Seminar*, June 11-13, Vancouver, BC. Environment Canada, Ottawa, ON, Canada, pp. 809-822.
- Walavalkar, A.Y. and A.K. Kulkarni. 2000. **Combustion of Floating, Water-in-oil Emulsion Layers Subjected to External Heat Flux.** In: *Proceedings of the Twenty-third Arctic Marine Oilspill Program (AMOP) Technical Seminar*. Environment Canada, Ottawa, ON, Canada, pp. 847-856.
- Walavalkar, A.Y. and A.K. Kulkarni. 2001. **Combustion of Mixtures of Weathered Alaskan Crude Oils and Water under External Heat Flux.** In: *Proceedings of the Twenty-fourth Arctic Marine Oilspill Program (AMOP) Technical Seminar*. Environment Canada, Ottawa, ON, Canada, pp. 755-765.
- Walton, W.O., D.O. Evans, K.D. McGrattan, H.R. Baum, W.H. Twilley, D. Madrzykowski, A.D. Putorti, R.G. Rehm, H. Koseki, and E.J. Tennyson. 1993. **In Situ Burning of Oil Spills: Mesoscale Experiments and Analysis.** In: *Proceedings of the Sixteenth Arctic and Marine Oilspill Program (AMOP) Technical Seminar*, June 7-9, Calgary, AB. Environment Canada, Ottawa, ON, Canada, pp. 679-734.
- Wu, N., M. Baker, G. Kolb, and J.L. Torero. 1997. **Ignition, Flame Spread and Mass Burning Characteristics of Liquid Fuels on a Water Bed.** In: *Proceedings of the Twentieth Arctic and Marine Oilspill Program (AMOP) Technical Seminar*, Environment Canada, Ottawa, ON, Canada, pp. 769-793.
- Yumoto, T. 1971. **Heat Transfer from Flame to Fuel Surface in Large Pool Fires.** *Combustion and Flame*, 17:108-110.

CHAPTER 5. IN SITU BURNING IN ICE AND SNOW CONDITIONS

5.1 Introduction

In situ burning has been considered as a primary spill countermeasure for oil spills in ice-affected waters, from the start of offshore drilling in the Beaufort Sea in the 1970's. Field trials at that time demonstrated that on-ice burning offered the potential to remove almost all of the oil present on the surface of the ice with only minimal residue volumes left for manual recovery. Since then, a great many studies and trials have been undertaken to investigate and document burning of large crude oil slicks (both fresh and emulsified) in cold open water, slush ice, drift ice, pack ice and on solid ice.

The review of literature on in situ burning in ice revealed three categories of relevant references:

1. burning oil on solid ice (in melt pools or when spilled directly on ice);
2. burning oil/snow mixtures; and,
3. burning oil in slush, brash, drift and pack ice.

The state of knowledge of in situ burning in ice-affected waters is based on three types of experience:

- Small and mid-scale tests conducted in basins or test pans;
- Mid-scale and large scale tests conducted as part of field trials; and,
- Historic spill incidents in ice where burning was used.

5.2 Burning Oil on Solid Ice

In situ burning is the countermeasure of choice to remove oil pools on ice. Such pools can be created by a spill onto the ice or by the release of encapsulated oil due to spring thaw. There is a high degree of knowledge on the ignition and burning of oil on melt pools. For large areas of melt pools, helicopters deploying igniters could be used to ignite individual pools of oil. For smaller areas, manual ignition techniques could be employed. The method used would depend upon the availability of aircraft that could operate safely to the regions of contamination, and the vessels or other watercraft available to access the oil from the surface.

The idea of burning oil on ice first arose as a result of a series of experiments by the USCG on ice off Barrow, Alaska in 1971 (Glaeser & Vance, 1971; McMinn, 1972). These experiments showed for the first time that oil spilled on ice could be ignited simply with an oil-soaked rag and burned with high removal efficiencies (80+%) without the need for containment or promoters.

The next major step forward came as a result of a large experimental crude oil spill under landfast sea ice in the Beaufort Sea at Balaena Bay in 1974/75 (NORCOR, 1975). The main purpose of this experiment was to investigate the fate and behaviour of 54 m³ of fresh crude oil released under landfast sea ice in the Arctic. Once the oil appeared in melt pools on the ice surface during the spring a variety of cleanup techniques were tried: in situ burning of the oil proved by far the most effective. Ignition was achieved using gasoline-soaked paper towels. Individual burns achieved up to 90% oil removal, and one burn (**Figure 5-1**) removed 20 m³ of oil from the surface. Overall about 60% of the oil originally discharged under the ice was

removed by burning; the remainder evaporated, was removed manually or naturally dispersed when the ice sheet broke up.



Figure 5-1 Burn of oil in melt pools at Balaena Bay, NWT 1975. (Source: D. Dickins)

Belicek & Overall (1976) conducted a series of oil weathering and burning tests near Yellowknife, NWT in metal pans designed to mimic melt pools. The tests examined minimum ignitable thickness, burn efficiency, igniters and additives. Ignition was easily achieved by propane torch: Kontax igniters proved unreliable. Overall burn efficiencies averaged 80%. Again, the use of additives did not improve burn efficiency.

Energetex (1977) undertook a large study on the minimum ignitable thickness of crude oils on melt pools; the effects of wind on in situ burning of oil on melt pools; and, the potential for herding agents to thicken oil on melt pools. They found that even low winds could herd slicks to a downwind edge and allow ignition and burn efficiencies up to 85%. The experimental slicks could be ignited and burned in winds up to 7 m/s. Herding agents could also thicken slicks on melt pools.

Over the winter and spring of 1979/80 a large experimental spill simulating a subsea blowout under sea ice was carried out (Buist *et al.*, 1981; Dickins & Buist, 1981). The goals of the experiment related to in situ burning were:

- To further understand how oil behaved in ice, and especially what effect gas had on under ice spreading and on the rate the oil migrated to the surface in the springtime during the melt period.
- To elucidate the optimum time for burning of oil contained in melt pools so that environmental damage could be minimized.
- To test, under realistic conditions, devices that could ignite oil so that it could be burned in situ.

- To measure how much oil was burned, how much remained as a residue and to obtain data on the chemical nature of the residue.
- To provide information on the combustion products associated with burning oil contained in melt pools.

The experiment took place in three phases, approximately eight kilometres offshore of McKinley Bay in the Beaufort Sea, under first-year landfast sea ice. Approximately 19 m³ of crude oil was discharged under the ice in conjunction with gas (air). The average thickness of the oil under the ice was 1-mm. The following results were obtained:

- Of the oil discharged, about 80% appeared on the ice surface prior to spring breakup.
- Of the oil discharged, approximately 80% was removed from the marine environment and 20% dispersed naturally.
- Fifty percent of the oil on the ice surface was burned in situ using helicopter-deployable igniters (Figure 5-2).

This experiment confirmed that wind will generally blow oil on melt pools to the downwind ice edge, where it will be herded to thicknesses of approximately 10-mm. Individual melt pool burn efficiencies are thus on the order of 90%. The average burn rate of small melt pool slicks was 1 mm/min. Table 5-1 shows the measured size distribution of oil slicks on melt pools (this has been used to estimate the likely overall burn efficiencies of oil on melt pools from subsea blowouts with different oil discharge rates and under-ice coverage - e.g., Glover & Dickins,

Table 5-1: Distribution of average oiled melt pool sizes – 1980, McKinley Bay, NWT						
	Oil Pool Size Range (pools greater than)					
	All	1 m ²	5 m ²	10 m ²	20 m ²	100 m ²
No of pools/ha	80	60	30	15	4	2
% oil in range	100	95	85	75	45	40

1999; Imperial Oil, 2011).

As part of the larger field experiment a study of burning crude oil on ice in wind conditions was undertaken. A key finding of this work was that it was possible to burn oil on sea ice at air temperatures as low as -32°C (Figure 5-3) and in winds up to 9 m/s (Energetex, 1981).

In the spring of 1981, oil from an experimental spill under landfast sea ice in Alaska was released to the surface by drilling into the encapsulated lens, and burned after it naturally rose to the surface. An estimated 95% removal efficiency was reported (Nelson & Allen, 1982).



Figure 5-2 Burning crude oil from a subsea blowout under ice. (Source: I. Buist)

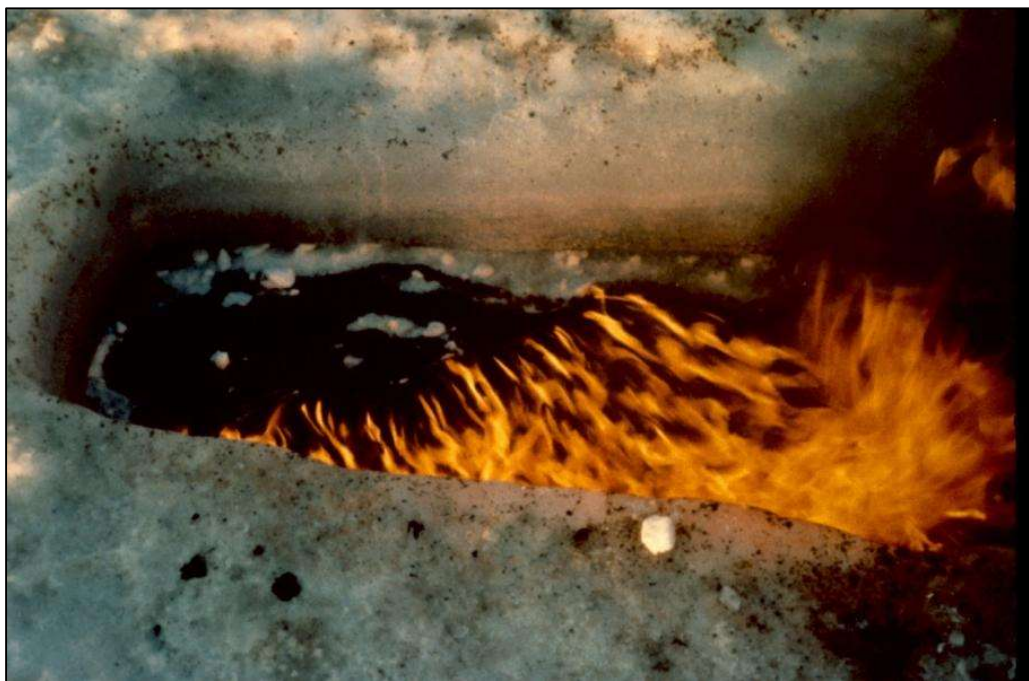

Figure 5-3 Burning crude oil on ice at -31.5°C . (Source: I. Buist)

As part of a small field experiment to study the fate and behaviour of emulsions encapsulated in first-year sea ice (Buist *et al.*, 1983), emulsions that appeared on the ice surface in spring and a control slick of crude oil were ignited and burned: a 73% oil removal efficiency was achieved with the crude oil and a 63% oil removal efficiency was achieved with the emulsion (50% water content).

In 1991 (Bech *et al.*, 1992) and 1993 (Guénette *et al.*, 1995) a series of small burns of fresh, weathered and emulsified crude was carried out on landfast ice at Svalbard in 4m² basins cut in the ice and filled with water (simulating melt pools). The results were:

- Fresh, unemulsified crude oil (8-mm thick) burns achieved an oil removal efficiency of 85+%.
- This burn efficiency decreased slightly with evaporation and quickly with increasing water content over 10%.
- Gelled crude proved to be a better igniter than gelled gasoline for emulsions (Figure 5-4).
- The burn rate decreased for both increasing evaporation and increasing water content.
- The maximum wind speed that these burns could take place in was 10 to 11 m/s.



Figure 5-4 Igniting emulsions on water on ice with modified igniters. (Source: I. Buist)

As part of an experimental spill under landfast ice at Svalbard in 2006, crude oil that surfaced on the ice at the end of the experiment was ignited and burned (Dickins *et al.*, 2008). More than 95% of the oil was consumed in the fire (a slick of 27% evaporated Statfjord crude initially 35-mm thick and 69-m² in area).

5.2.1 Burning Oil in Snow

Some tests of burning oil that had been covered by drifting snow were conducted by McMinn (1972). He reported that the snow hindered ignition and flame spreading. The first known parametric tests of oil ignition and burning in snow are reported by Energetex (1981). Two series of tests are discussed:

1. Burns in small pits (100 x 50 x 10-cm) dug in an ice sheet involving pre-mixed blends of either fresh Prudhoe Bay crude or Arctic P40 diesel in snow. The snow content of the mixtures ranged from 55 to 83% by weight. Ambient temperatures were on the order of 0°C.
2. Burns in small trenches (approximately 150 x 50 x 20-cm) cut in sea ice at McKinley Bay, NWT in the winter of 1979/80 with the same two oil types. The snow content of these mixtures ranged from 26 to 69% by weight. Air temperatures ranged from -31.5°C to 3°C (Figure 5-3).

The results showed that:

- The maximum snow content (by weight) that could be ignited without a primer was 33% for diesel and 40% for fresh Prudhoe Bay crude. Burn efficiencies for these were in the 70%+ range.
- Air temperatures from -31.5 to +3°C did not appreciably affect the burns.

Nelson & Allen (1982) conducted a series of field tests to burn oil sprayed onto snow at Prudhoe Bay. One cubic metre of fresh Prudhoe Bay crude was sprayed onto 465 m² of snow-covered ice resulting in average oil coverage of 2.2-mm. The oiled snow was left undisturbed for two weeks at one site and ignited just after application at another. Oil penetration into the snow was initially on the order of 1-cm. Oiled snow samples indicated a water content of 75 to 90%. Some isolated oiled snow in depressions did ignite, neither the fresh nor 2-week old oiled snow could be burned efficiently in situ. It was necessary to plough the oiled snow into a volcano-shaped pile and ignite the inside: the heat then melted snow, allowing the oil to run to the center of the pile and feed the fire (Figure 5-5).

Sveum *et al.* (1991) report on a series of experiments at Svalbard on burning oil in snow. In these tests, mixtures of snow and either diesel or fresh Oseberg crude were tested. In the small-scale tests (using about 8 litres [0.5 bbl] of snow), unaided ignition was possible with up to between 25 and 50% snow by volume (approximately 16 and 23% snow by weight). Priming the mixture with fuel was necessary at higher snow contents. The efficiency was uniformly 90% or greater, since once the fire was started it would melt the snow and release the oil for burning on top of the melt water in the test vessel. Little difference in the results for the two oils was noted. In field tests, a large oiled area used for oil-in-snow spreading experiments was ignited and burned successfully using gasoline as a primer. In some experiments the snow was piled into heaps and in others it was left undisturbed.

In situ burning has been used operationally many times to remove fuel oil spills on ice by directly igniting the fuel (Figure 5-6) or placing oiled snow in an incinerator (Figure 5-7).



Figure 5-5 Burning oiled snow in volcano-shaped piles. (Source: Alaska Clean Seas)



Figure 5-6 Burning a diesel spill in snow on ice. (Source: D. Dickins)



Figure 5-7 Burning oiled snow in a portable air-curtain incinerator. (Source: SL Ross Environmental Research)

5.3 Burning Oil in Drift and Pack Ice Conditions

The first recorded tests of ISB in broken ice conditions formed part of the “Tier II” demonstrations performed by the Alaskan oil industry in 1983 (Shell *et al.*, 1983; SL Ross, 1983). These involved test burns in a pit at East Dock in Prudhoe Bay, AK (Figure 5-8). For two of the tests large ice blocks mined from the Beaufort Sea were grounded in the pit and Prudhoe crude oil was poured onto the pit water surface, allowed to drift, ignited, and burned. For the other two tests, the oil was placed among floating brash ice (40 to 50% coverage of 0.3 to 1.5-m floes). In the first test with 140-L (0.25 bbl) of weathered Prudhoe crude the oil spread to cover an area of 90-m² with an average thickness of 2.8-mm among the ice and could not be ignited in six attempts. The second free-floating test involved 1-m³ of fresh Prudhoe crude spread through 450-m² of brash ice with an average thickness of 4.6-mm. The oil was successfully ignited and burned for 7-minutes as free-floating oil. The oil burned for an additional 23-minutes when herded against the downwind edge of the pit.

Several subsequent ignitions of herded oil were made after the main fire extinguished. In all, approximately 73% of the oil was burned.

In 1984, 1985, and 1986 burn tests were conducted at OHMSETT inside a wood-boomed area containing large (0.5 x 1 x 0.25-m), tethered, 140-kg freshwater ice blocks (Smith & Diaz, 1987). Slightly weathered Prudhoe Bay and Hibernia crudes were used. The boomed area was 46.5-m².



Figure 5-8 Burns in broken ice at East Dock, Prudhoe Bay, AK, 1983.
(Source: A. Allen)

In the 1984 tests the ice block coverage ranged from 45 to 60%. The average distance between the ice blocks was 20 to 30-cm. Oil was placed on the water between the blocks, with an average thickness of 2 to 4-mm. Three tests were conducted in calm conditions and one in waves. All ignited easily and burned efficiently, with removals of 85 to 95%.

In 1985 and 1986 higher ice concentrations and emulsified oils were tested. With ice block coverage in the 75 to 80% range, fresh and evaporated crudes had burn efficiencies of 60% to 70%, while slightly emulsified crudes were much less burnable (10% to 55% removal, with the lowest efficiency associated with an 18% water-content emulsion).

Also in 1985/86, a series of experiments on oil burning in ice leads was conducted in an ice basin in Calgary (Brown & Goodman, 1987). Twenty-five burns of weathered Norman Wells crude were carried out under varying wind conditions in leads of various sizes and geometries cut in an ice sheet. It was found that burning efficiencies of up to 90% were possible if moderate winds herded the oil into long narrow leads. For leads of other geometries with similar winds, efficiencies were as low as 70%. Winds of up to 4 m/s across a narrow lead caused no oil herding and resulted in low efficiency burns. Wind herded oil could be ignited at either the upwind or downwind edge with similar burning results. Evaporation of the oil of up to 20% did not significantly affect burn efficiency in moderate winds.

As a small part of the same study two tests of burning in brash ice were conducted (Brown & Goodman, 1987). The oil used was a 10% evaporated crude. Breaking up the ice sheet that had grown beneath the oil while it weathered in the lead created brash ice. The ice pieces were all less than 2-cm in any dimension and were thoroughly mixed into the oil prior to ignition. The presence of brash ice is reported to have:

- Significantly reduced the flame spreading velocity (from 0.07 m/s without ice to 0.03 m/s with brash ice);

- Significantly lowered the oil burning rate (by a factor of about 5); and,
- Somewhat lowered the burn efficiency (from about 85 to 90% to 70 to 80%).

It was noted that brash ice covering <50% of the surface was completely melted during one burn.

An experimental in situ burn in close pack ice conditions was carried out (SL Ross & DF Dickins, 1987) in 1986, off the coast of Nova Scotia. Three 1 m³ spills of Alberta Sweet Mixed Blend (ASMB) crude were released and their behaviour was monitored. Two of these releases, in brash ice in close pack conditions (9+/10ths) were ignited and burned (**Figure 5-9**). The oil spread through and saturated the slush and brash over areas of 35 and 36 m², equivalent to a thickness of about 30-mm. Several hours after release, each spill was ignited using a burning oil-soaked sorbent. Removal efficiencies (based on timing the area of the burns and using a 2 mm/min regression rate) were 93% and 80%.



Figure 5-9 Burning crude oil in 9+/10ths pack ice off Cape Breton, 1986. (Source SL Ross Environmental Research)

In 1992 several mid-scale burn tests were conducted in a rectangular basin cut into the ice sheet on a fjord at Svalbard (Bech *et al.*, 1993). One test involved 4 m³ of a mixture of fuel oils pumped into 9+ tenths brash ice (a mixture of ice rubble pieces approximately 30-cm in size and frazil ice from blowing snow). The estimated thickness of the oil was 30-mm at ignition. Ignition was accomplished with a small, gelled crude igniter, and a burn efficiency of 90% was obtained with waves (about 40-cm x 4-m) being generated in the basin (**Figure 5-10**). Similar tests with 12.5 % and 25% water content emulsions proved extremely difficult to ignite and burn in waves. In calm conditions, with sufficient primer,



Figure 5-10 Burning oil in brash ice with waves at Svalbard 1992. (Source: I. Buist)

ignition and burning was achieved but with lower removal efficiencies compared with unemulsified oil. It was concluded that small ice floes and slush did not negatively affect the burning of the thick oil slicks.

In 1993, unsuccessful attempts were made to ignite seven-day weathered crude oil slicks in a 70% ice cover at an experimental spill in pack ice in the Barents Sea (Singsass *et al.*, 1994).

In 1994 another series of experiments on burning crude oil and emulsions in brash ice were carried out in a 15-m diameter circular basin cut in the ice of a fjord at Svalbard (Guénette & Wighus, 1996; Guénette & Sveum, 1994). Fresh, weathered, and emulsified Statfjord crude oil was used. The basin contained slush ice from blowing snow and ice pieces from 0.5 to 3-m in diameter. In a pre-test burn, 200-L (1.26 bbl) of fresh crude was easily ignited and burned in compacted brash ice. The oil initially spread to cover 9-m², equivalent to a thickness of 22-mm. At the end of the burn (14-minutes) it had spread to 16-m². No removal efficiency was recorded. In the first test, 8-m³ of fresh crude was placed in the basin with 20% ice cover (most of the ice and slush was submerged by the thick oil) and an initial thickness of 56-mm. This was easily ignited with a simple gasoline-soaked sorbent and resulted in a 99% removal efficiency. The next test involved 6-m³ of a 50% water-in-18%-evaporated-crude emulsion in 50% ice coverage. This proved very difficult to ignite, eventually requiring 4-m³ of fresh oil as primer to achieve 75% removal efficiency. The final test involved 2.7-m³ (30-mm) of 20% water-in-crude emulsion in a 50% ice cover, which was successfully ignited with an emulsion-breaking igniter and gasoline as primer. A removal efficiency of 95% was achieved, even in the prevailing 8 to 11 m/s winds, which herded the burning oil and ice against the downwind ice edge.

In 2002/03 a series of experiments was done to investigate minimum ignitable thickness, combustion rate, residue amount, and the effects of waves on thin oil slicks burned in situ in

frazil or slush ice typical of freeze-up and brash ice typical of break-up (SL Ross *et al.*, 2003). The focus was on thin oil slicks, such as those that could be generated by blowouts or sub-sea oil pipeline leaks. The project consisted of small-scale burns in a chilled wave tank in Ottawa and mid-scale burns in an outdoor wave tank at Prudhoe Bay, AK (Figure 5-11).

The small-scale experiments involved:

- Minimum ignitable thickness tests for three degrees of weathering for each of four Alaskan crudes on open water, ice cubes (representing brash) and crushed ice (pulverized ice cubes representing frazil, or slush); and,
- Burn rate and removal efficiency tests in calm and low wave conditions with 3-mm thick slicks spread out on top of the ice for three degrees of weathering for each crude on open water, ice cubes, and crushed ice.



Figure 5-11 Test burns in brash ice with waves in Prudhoe Bay, 2003. (Source: D. Dickins)

The mid-scale tests mimicked the small-scale matrix and involved burn rate and removal efficiency tests in calm water and low wave conditions with 3-mm thick slicks spread out on top of open water, brash ice (grown in a nearby pit from brackish Prudhoe Bay water) and a layer of frazil (also referred to as grease or slush) ice (simulated by using snow in water) for selected degrees of weathering of the various crudes.

In general, the “rules-of-thumb” derived from the experiments were:

- The minimum ignitable thickness for fresh crude in frazil ice or small brash ice pieces is up to double that on open water, or about 1 to 2-mm.

- The minimum ignitable thickness for evaporated crude oil in frazil ice or small brash ice pieces can be higher than on open water, but is still within the range quoted for weathered crude on water, about 3-mm with gelled gasoline igniters.
- For a given spill diameter, the burn rate in calm conditions is about halved on relatively smooth frazil/slush ice and halved again on rougher, brash ice. Wave action slightly reduces the burn rate on open water, but the halving rule seems to apply in waves as well.
- The residue remaining on broken ice in calm conditions is about 50% greater than that on open water or 1.5-mm. The residue remaining in brash or frazil ice in waves is slightly greater than in calm conditions, at about 2-mm.

The combination of the minimum ignitable thickness rule of 3-mm for weathered oil, and the residue thickness rules imply that 3-mm slicks in brash or frazil ice can be burned in situ with removal efficiencies on the order of 50% in calm conditions and 33% in wave conditions.

SINTEF ran a large experimental programme to quantify the ignitability and burnability of weathered crude oils in broken ice condition (Brandvik *et al.*, 2010). The experiments involved lab-, meso-, and field-scale experiments in which five different crude oils were weathered in open water, 50% brash ice, and 90% brash ice. Samples of the weathered oils were taken over time and their ignitability and burnability were tested in a specialized burn test apparatus. The weathered oils (250 to 400 L, depending on water content) from the field tests were burned in their entirety in a flume cut in fast ice (Figure 5-12). The study concluded that:

- All the oils eventually became unignitable due to the combination of evaporation and emulsification
- When weathered in ice conditions, the oils remained ignitable longer than they did in open water due to the slower evaporation and emulsification
- Increasing ice concentration increased the “window of opportunity” for successful ignition and effective burning.

The data has been incorporated into an algorithm in the SINTEF Oil Weathering Model to predict windows of opportunity for in situ burning (Brandvik *et al.*, 2010b).

As a follow-up to these experiments, in 2009 as a part of a larger Oil in Ice Joint Industry Project (JIP) two experimental spills were released in close pack ice (7 to 9/10ths) in the Barents Sea (Brandvik *et al.*, 2010c; Fritt-Rasmussen & Brandvik, 2011). One consisted of 2 m³ of fresh crude which was left to weather for 12-hours before being ignited with plastic baggies of gelled gasoline. A large burn ensued (Figure 5-13) that consumed approximately 95%. Another spill of 7-m³ of fresh crude was left to weather for 5-days in pack ice ranging in concentration from 7 to 9 tenths. Samples of the oil were



Figure 5-12 Burning oil weathered in brash ice in meso-scale burn pit at Svalbard, 2007. (Source: SINTEF)



Figure 5-13 Burning 2 m³ experimental spill in pack ice on the Barents Sea 2009. (Source: SINTEF)

removed and their ignitability measured using the newly-developed burning cell. The measurements indicated that the oil was ignitable for four days, but not ignitable on the fifth

day. An igniter placed on the test slick failed to ignite it on the fifth day. The results showed that spills in pack ice conditions have an extended window-of-opportunity for in situ burning, due to slower weathering of the oil in pack ice, compared with open-water conditions.

Another part of the JIP on Oil in Ice involved testing whether conventional fire booms could be used to burn oil in drift ice (up to 3/10ths concentration) (Potter & Buist, 2010). This was accomplished with two different booms, the Elastec/American Marine (aka 3M) fire boom and the Applied Fabrics Technologies (AFTI) PyroBoom. The booms were tested in two different ice conditions: the former in a field of 3 to 5/10ths ice, and the latter in trace ice conditions. Both booms proved to be suitable to the task, and were able to contain a modest number of ice floes as would be encountered in a “collect-and-burn” operation in light ice concentrations.

In each test, a high percentage of the original 4 m³ oil was removed through in situ burning, some 98% in the first test (Figure 5-14) and 89% in the second (Figure 5-15). The burn in the second test was less effective and took much longer due to the presence of more densely packed brash and frazil ice and due to the presence of waves.

In summary, it is feasible to use fire-resistant booms in light drift ice to collect oil and ice for in situ burning. This technique should have excellent applicability for spills in trace to 3/10ths ice concentration.

From 2003 through 2012, a programme of research on using herding agents to thicken oil slicks in drift ice has been ongoing (Buist *et al.*, 2011). Details of this research are provided in the next Chapter.



Figure 5-14 Test with 3 to 5/ 10th small floes. (Source: SINTEF)



Figure 5-15 Test with brash and slush ice. (source: SINTEF)

5.4 Burning Accidental Spills in Ice Conditions

The following items highlight known situations where burning of fuel oil and/or crude was either attempted or carried out during actual response efforts involving oil in ice. This list is not intended to be all-inclusive and only covers incidents that have been reported in the literature:

- **M/T *Raphael*, 1969** (Lampela, 2000): *M/T Raphael* grounded in Finnish waters in the Gulf of Finland about 30 nautical miles east of Helsinki in the Porvoo archipelago. The *Raphael* was a single bottom vessel, and due to the accident about 200-tonnes of crude oil was released

among the ice. The main part of the visible oil (85%) was burned and a significant part was also collected among the ice. Holes were made in order to collect oil from beneath the ice, and the burning was continued when the ice cover began to give way.

- **Tanker Arrow, Nova Scotia, Canada, February 1970** (reported in McLean, 1972): Efforts were made to burn oil in the early stages of the spill where oil was congregated in heavy pools against a forming fast ice front. Ignition was unsuccessful and further attempts were abandoned. Lack of success was mainly attributed to the cold temperatures, combined with the extreme non-volatility of the Bunker C under the prevailing conditions.
- **Othello, Sweden, March 1970** (Anonymous, 1970; Freiberger & Byers, 1971; Energetex, 1979): In March, 1970, the *Othello* collided with the *Katelsia* in Tvalhavet Bay near Stockholm, Sweden and spilled about 95,000-L (600 bbl) of heavy fuel oil in broken ice. Early efforts by the Swedish Coast Guard to promote ignition of the oil with kerosene failed. Cab-O-Sil was applied by hand from small tugs to 0.3 to 0.6-m diameter pools of oil contained by ice and ignited with small amounts of primer. It is reported that this successfully removed the oil.
- **Deception Bay Tank Farm, Hudson Strait, Quebec, June 1970** (Ramseier *et al.*, 1973): Spilled oil (diesel and gasoline) from ruptured storage tanks flowed out onto the fast ice and an estimated 190,000-L (1195-bbl; 12% of the spill) became incorporated into a well-developed and active tidal crack system (12 to 19-ft. diurnal range). Oil pooled in tidal cracks was successfully ignited and burned. Some emulsification of oil in the cracks was noted and attributed to the grinding action of ice motion through the tidal cycle.
- **Ume River, Sweden, January 1972** (Jerbo, 1973): In January, 1972, 610-tonnes of diesel fuel was accidentally discharged into the icy Ume River in Sweden. The oil spread downriver into a small lake. A particulate sorbent product "Saneringsull" was used as a wicking agent and about 406-tonnes of oil was burned over a period of a month from a mixture of oil, ice, and snow on the lake.
- **Imperial St. Clair, Georgian Bay, Ontario, December 1976** (Beckett, 1979): The tanker grounded in an area of unstable and shifting new winter ice, losing an estimated 215,800-L (1360-bbl) of diesel fuel and gasoline. Once the vessel was moved from the site, a successful burn of the diesel fuel saturated in the snow was carried out. Air temperatures were around -10°C. Ice conditions were still unstable at the time and personnel had safety lines attached. An initial fire started with an oil-soaked rag quickly spread. Further burns were carried out through the winter and into the early melt phase, some by gathering oil soaked snow into piles on the now stable ice but most with exposed pools during mild periods. One burn covering an area of 10 ft. x 100 ft. was estimated to have consumed 1500-L (95-bbl). The overall outcome was that an estimated 80 to 95% of the spilled oil was evaporated or burned in the original and subsequent burns.
- **Bouchard #65, Buzzards Bay Spill, MA, January 1977** (Ruby *et al.*, 1977): 306,800-L (1930 bbl) of No. 2 fuel oil was spread and mixed into a dynamic mix of broken pans, rafted sheets and slush. Burning was used with some success at the original site of the barge grounding. Wicking agents soaked with jet fuel were dropped by helicopter into the oil pools. Several thousand gallons (est.) were burned in this manner with fires lasting for up to 2-hours. The burns were not considered totally effective due to a lack of enough large pools to make it worthwhile, inability of the fire to spread naturally along the lightly oiled block and brash ice from one pool to another and the large amount of particulate matter which left a black coating on the ice downwind of the fires.

- **Edgar Jourdain, Hall Beach, NWT, Spring 1981** (Brander-Smith *et al.*, 1990): In September, 1980, the cargo vessel *Edgar Jourdain* went aground off Hall Beach, N.W.T., and spilled 50,000-L (315 bbl) of marine diesel fuel. Within a week, ice began to grow and froze the remaining oil into the ship. The following spring the remaining fuel was deliberately burned in the ship.
- **Warwick Lake, Ontario, January 1983** (Burns 1988): In January, 1983, about 59,000-L (371 bbl) of diesel fuel leaked from a storage tank into Warwick Lake, Ontario. Over the ensuing winter and spring about 50,000-L (315 bbl) of this was burned from snow, on ice and after being pumped from beneath ice.
- **Brunswick Naval Air Station, Maine, March 1993** (Michel *et al.*, 2005): 240-m³ of JP-5 was spilled from a pipeline valve at a newly-constructed tank farm. The oil was naturally contained in the pond by extensive ice and about 1-m of snow. About 2/3 of the oil was recovered by vacuum trucks over one week. The rest of the oil was not accessible, and it was burned eight days after the spill. The oil burned for five-hours, and smaller burns were conducted over the next two days. About 1700-L (11 bbl) of oil remained after the burn (98% burned). There was no burn residue, only unburned oil.

5.5 Summary

Figure 5-16 is a map showing the locations of all the experimental and actual burns in ice-affected waters that have occurred worldwide since 1958. **Figure 5-17** shows the timeline for the burns.



- | | |
|--|---|
| <ul style="list-style-type: none"> A: USCG experiments near Barrow, AK, 1971-72 B: Experiments by McMinn near Barrow, AK, 1971-72 C: Experimental spill in Balaena Bay, Canada, 1974-75 D: Experiments in Yellowknife, Canada, 1976 E: Experiments by Energetex in Waterloo, Canada, 1977 F: Experiments at McKinley Bay, Canada, 1979-80 G: Experiments by Energetex at Mckinley Bay, Canada, 1979-80 H: Experiments at McKinley Bay, Canada, 1981 I: Experiments at Prudhoe Bay, AK, 1982 J: Experiments at McKinley Bay, Canada, 1982 K: Tier II burn tests at Prudhoe Bay, AK, 1983 L: Experiments at OHMSETT, NJ, 1984-86 M: Experiments at Cape Bretton, Canada, 1986 N: Experiments in Calgary, Canada, 1986 O: Experiments at Svalbard, Norway, 1990-94 P: Experiments in Barents Sea, 1993 Q: Experiments at Prudhoe Bay, AK, 2002-03 R: Experiments at Svalbard, Norway, 2006-08 S: Experiments in Barents Sea, 2008-09 | <ul style="list-style-type: none"> 1: Pipeline Spill, Near Normal Wells, Mackenzie River, Canada, 1958 2: Tanker <i>Raphael</i> spill, Finland, 1969 3: Tank farm accident in Deception Bay, Canada, 1970 4: Tanker <i>Arrow</i> spill, Chedabucto Bay, Canada, 1970 5: Collision of <i>Othello</i> and <i>Katylisia</i>, Tralhavet Bay, Sweden, 1970 6: Diesel spill in ice choked river, Sweden, 1972 7: <i>Imperial St. Claire</i> spill in Lake Huron/Georgian Bay, Canada, 1976 8: Barge <i>Bouchard</i> #65 accident in Buzzards Bay, MA, 1977 9: Cargo vessel <i>Edgar Jourdain</i> spill, Hall Beach, Canada, 1980 10: Storage tank leak, Warwick Lake, Canada, 1983 11: Tank farm release, ME, 1993 |
|--|---|

Figure 5-16 Map showing experimental spills and actual incidents involving burns in ice.

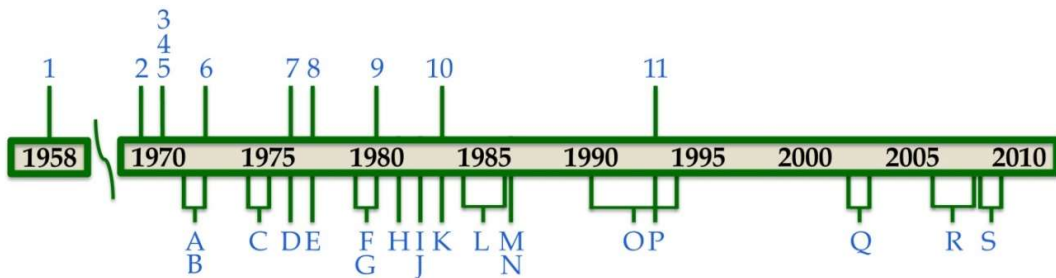

Figure 5-17 Timeline of experimental spills and actual incidents involving burns in ice.

References for Chapter 5

- Anonymous. 1970. **Oil for Burning**. *Marine Pollution Bulletin*, 1(12):181.
- Bech, C., P. Sveum, and I.A. Buist. 1992. **In Situ Burning of Emulsions: the Effects of Varying Water Content and Degree of Evaporation**. In: *Proceedings of the Fifteenth Arctic and Marine Oilspill Program (AMOP) Technical Seminar*, June 10-12, Edmonton, AB. Environment Canada, Ottawa, ON, Canada, p. 547-559.
- Bech, C., P. Sveum, and I.A. Buist. 1993. **The effect of wind, ice and waves on the in situ burning of emulsions and aged oils**. In: *Proceedings of the Fifteenth Arctic and Marine Oilspill Program (AMOP) Technical Seminar*, June 7-9, Calgary, AB. Environment Canada, Ottawa, ON, Canada, pp. 735-748.
- Beckett, C.J. 1979. **The Grounding of the Imperial St. Clair - A Case History of Contending with Oil in Ice**. In: *Proceedings of the 1979 Oil Spill Conference*, Los Angeles, CA. American Petroleum Institute, Washington, DC, U.S., pp. 371-375.
- Belicek, K. and J. Overall. 1976. **Some Aspects of Weathering and Burning of Crude Oil in a Water-And-Ice Environment**. Arctic Petroleum Operators Association, Calgary, AB. APOA Project 107, 34 p.
- Brander-Smith, D., D.P. Therrien, and J. Tobin. 1990. **Protecting Our Waters: Public Review Panel on Tanker Safety and Marine Spills Response Capability. Final Report**. September 1990. Minister of Supply and Services Canada 1990. Catalogue No. EN21-91/1990 E.
- Brandvik, P.J., J.L.M. Resby, P.S. Daling, F. Leirvik, and J. Fritt-Rasmussen. 2010. **Meso-Scale Weathering of Oil as a Function of Ice Conditions: Oil Properties, Dispensability and In Situ Burnability of Weathered Oil as a Function of Time**. SINTEF Marine Environmental Technology report no. 15563. SINTEF Materials and Chemistry, Trondheim, Norway.
- Brandvik, P.J., P.S. Daling, and J.L.M. Resby. 2010b. **Mapping Weathering Properties as a Function of Ice Conditions: a Combined Approach using a Flume Basin Verified by Large Scale Field Experiments**. In: *Proceedings of the 33rd Arctic and Marine Oilspill Program (AMOP) Technical Seminar on Environmental Contamination and Response*, Environment Canada, Ottawa, ON, Canada, Vol. 2, pp. 701–723.
- Brandvik, P.J., P.S. Daling, L-G. Faksness, J. Fritt-Rasmussen, R. Daae, and F. Leirvik. 2010c. **Experimental Oil Release in Broken Ice – a Large-Scale Field Verification of Results From Laboratory Studies of Oil Weathering and Ignitability of Weathered Oil Spills**. SINTEF Materials and Chemistry, Marine Environmental Technology Report No. 15549. SINTEF, Trondheim, Norway.
- Brown, H.M. and R.H. Goodman. 1987. **In Situ Burning of Oil in Experimental Ice Leads**. Environmental Studies Revolving Funds Report No. 064, Environment Canada, Ottawa, ON, Canada, 33 p.
- Buist, I., W. Pistruzak, and D.F. Dickins. 1981. **Dome Petroleum's Oil and Gas Under Sea Ice Study**. In: *Proceedings of the Fourth Arctic and Marine Oilspill Program (AMOP) Technical Seminar*, June 16-18, Edmonton, AB. Environment Canada, Ottawa, ON, Canada, pp. 647-686.
- Buist, I.A., S.G. Potter, and D.F. Dickins. 1983. **Fate and behaviour of water-in-oil emulsions in ice**. In: *Proceedings of the Sixth Arctic and Marine Oilspill Program (AMOP) Technical Seminar*, June 14-16, Edmonton, AB. Environment Canada, Ottawa, ON, Canada, pp. 263-279.
- Buist, I.A., S.G. Potter, T. Nedwed, and J. Mullin. 2011. **Herding Surfactants to Contract and Thicken Oil Spills in Pack Ice for In Situ Burning**. *Cold Regions Science and Technology* 67:3–23.
- Burns, R.C. 1988. **Cleanup and Containment of a Diesel Fuel Spill to a Sensitive Water Body at a Remote Site under Extreme Winter Conditions**. In: *Proceedings of the Eleventh Arctic and Marine Oilspill Program (AMOP) Technical Seminar*, June 7-9, Vancouver, BC. Environment Canada, Ottawa, ON, Canada, pp.209-220.
- Dickins, D.F. and I.A. Buist. 1981. **Oil and Gas Under Sea Ice**. Prepared by Dome Petroleum Ltd for COOSRA, Report CV-1, Vols I and II. Calgary, AB, Canada.
- Dickins, D.F., P.J. Brandvik, J. Bradford, L-G. Faksness, L. Liberty, and R. Daniloff. 2008. **Svalbard 2006 Experimental Oil Spill Under Ice: Remote Sensing, Oil Weathering Under Arctic Conditions and Assessment of Oil Removal by In-situ Burning**. In: *Proceedings of the 2008 International Oil Spill Conference (IOSC)*, Savannah, GA. American Petroleum Institute, Washington, DC, U.S.

- Energetex Engineering (Energetex). 1977. **Ignition and Burning of Crude Oil on Water Pools and Under Arctic Spring Time Conditions**. Arctic Petroleum Operators Association (APOA) Project 141. APOA, Calgary, AB, Canada, 70 p.
- Energetex Engineering (Energetex). 1979. **A Review of Oil Slick Combustion Promoters**. Environment Canada Report EPS-3-EC-79-8. Environment Canada, Ottawa, ON, Canada, 48 p.
- Energetex Engineering (Energetex). 1981. **Burning of Crude Oil under Wind Herding Conditions**. Report prepared for Canadian Marine Drilling Ltd. Calgary, AB, Canada.
- Freiberger, A. and J.M. Byers. 1971. **Burning Agents for Oil Spill Cleanup**. In: *Proceedings of the 1971 Conference on Prevention and Control of Oil Spills*, June 15-17, Washington, DC. American Petroleum Institute, Washington, DC, U.S., pp.245-251.
- Fritt-Rasmussen, J. and P.J. Brandvik, 2011. **Measuring Ignitability for In Situ Burning of Oil Spills Weathered under Arctic Conditions: from Laboratory Studies to Large-Scale Field Experiments**. *Marine Pol. Bul.*, 62(8):1780-1785.
- Glaeser, J.L. and G.P. Vance. 1971. **A Study of the Behavior of Oil Spills in the Arctic**. Final Report to the USCG Office of Research & Development, Applied Technology Division, Groton, CT, U.S. Project Number 714708/A/001,002. 60 p.
- Glover, N.W. and D.F. Dickins. 1999. **Response Plans for Arctic Oil and Ice Encounters**. In: *Proceedings of the 1999 International Oil Spill Conference (IOSC)*, Seattle, WA. American Petroleum Institute, Washington, DC, U.S.
- Guénette, C.C. and P. Sveum. 1994. **In Situ Burning of Crude Oil and Emulsions IV: Uncontained and Contained in Broken Ice**. SINTEF report to NOFO and MSRC. Trondheim, Norway.
- Guénette, C.C., P. Sveum, C.M. Bech, and I.A. Buist. 1995. **Studies of in situ burning of emulsions in Norway**. In: *Proceedings of the 1995 Oil Spill Conference (Prevention, Preparedness, Response)*, February 27 – March 2, 1995, Long Beach, CA. American Petroleum Institute, Washington, DC, U.S., pp. 115-122.
- Guénette, C.C. and R. Wighus. 1996. In situ Burning of crude oil and emulsions in broken ice. *Proceedings of the 19th AMOP Technical Seminar*. Calgary, AB. June 12 -14, 1996. Environment Canada, Ottawa, ON, Canada, pp. 895-906.
- Imperial Oil Resource Ventures Limited. 2011. **Public Review of Arctic Safety and Environmental Offshore Drilling Requirements**. Submission For CFI 1 & 2. Submitted to the National Energy Board of Canada. Calgary, AB, Canada.
- Jerbo, A. 1973. **Two Types of Oil Spills in Swedish Inland Waters -Tests of New Materials, Ideas and Methods**. In: *Proceedings of the 1973 Conference on Prevention and Control of Oil Spills*, March 13-15, Washington, DC. American Petroleum Institute, Washington, DC, U.S., 559 p.
- Lampela, K. 2000. **Baltic Experiences with Spills in Ice**. In: *Proceedings of the International Oil and Ice Workshop*, Anchorage, AK. Organized by Alaska Clean Seas, Prudhoe Bay, AK.
- McLean, A.Y. 1972. **The Behaviour of Oil Spilled in a Cold Water Environment**. In: *Proceedings of the Offshore Technology Conference*, Houston, TX, U.S.
- McMinn, T.J. 1972. **Crude Oil Behaviour on Arctic Winter Ice**. U.S. Coast Guard, Office of Research and Development, Groton, CT, U.S. NTIS-AD-754261. 56 pp.
- Michel, J., Z. Nixon, and H. Hinkeldey. 2005. **Use of In Situ Burning as an Oil Spill Response Tool: Follow-up of Four Case Studies**. In: *Proceedings of the 2005 International Oil Spill Conference (IOSC)*, American Petroleum Institute, Washington, DC, U.S.
- Nelson, W.G. and A.A. Allen. 1982. **The Physical Interaction and Cleanup of Crude Oil with Slush and Solid First Year Sea Ice**. In: *Proceedings of the Fifth Arctic and Marine Oilspill Program (AMOP) Technical Seminar*, June 15-17, Edmonton, AB. Environment Canada, Ottawa, ON, Canada, pp. 37-58.
- NORCOR Engineering and Research Ltd. (NORCOR). 1975. **The Interaction of Crude Oil with Arctic Sea Ice**. Beaufort Sea Project Technical Report No. 27, Canada Department of the Environment, Victoria, BC, Canada.

- Potter, S.G. and I.A. Buist. 2010. **In-situ Burning in Arctic and Ice-covered Waters: Tests of Fire-resistant Boom in Low Concentrations of Drift Ice.** In: *Proceedings of the Thirty-third Arctic and Marine Oilspill Program (AMOP) Technical Seminar on Environmental Contamination and Response*, Environment Canada, Ottawa, ON, Canada, pp. 743-754.
- Ramseier, R.O., G.A. Gontcheff, and L. Colby. 1973. **Oil Spill at Deception Bay, Hudson Strait.** Canada Centre for Inland Waters Scientific Series, No. 29, Environment Canada, Ottawa, ON, Canada.
- Ruby, C.H., L.G. Ward, I.A. Fischer, and P.J. Brown. 1977. **Buzzards Bay Oil Spill - An Arctic Analogue.** In: *Proceedings of the Conference on Port and Ocean Engineering Under Arctic Conditions*, St. John's, NL, Canada, pp. 844-854.
- Shell Oil Company (Shell), Sohio Alaska Petroleum Company (Sohio), Exxon Company USA (Exxon), and Amoco Production Company (Amoco). 1983. **Oil spill response in the arctic, part 2: Field demonstration in broken ice.** Shell Oil Company, 108 p.
- Singsaas, I., P.J. Brandvik, P.S. Daling, M. Reed, and A. Lewis. 1994. **Fate and Behaviour of Oil Spilled in the Presence of Ice- A Comparison of the Results from Recent Laboratory, Meso-Scale Flume and Field Test.** In: *Proceedings of the seventeenth Arctic and Marine Oilspill Program (AMOP) Technical Seminar*, Volume 1. Environment Canada, Ottawa, ON, Canada.
- S.L. Ross Environmental Research Ltd. (SL Ross). 1983. **Evaluation of Industry's Oil Spill Countermeasures Capabilities in Broken Ice Conditions in the Alaskan Beaufort Sea.** Report to Alaska Department of Environmental Conservation, Juneau, AK, U.S.
- S.L. Ross Environmental Research Ltd. (SL Ross) and DF Dickins Associates Ltd. (DF Dickins). 1987. **Field Research Spills to Investigate the Physical and Chemical Fate of Oil in Pack Ice.** Environmental Studies Revolving Funds Report No. 062. 95 p.
- S.L. Ross Environmental Research Ltd. (SL Ross), DF Dickins Associates Ltd. (DF Dickins) and Alaska Clean Seas (ACS). 2003. **Tests to Determine the Limits to In Situ Burning of Thin Oil Slicks in Broken Ice.** Report to Minerals Management Service and ExxonMobil Upstream Research. Herndon, VA, U.S.
- Smith, N.K. and A. Diaz. 1987. **In-place burning of crude oils in broken ice.** In: *Proceedings of the 1987 Oil Spill Conference*, April 6-9, Baltimore, MD. American Petroleum Institute, Washington, DC, U.S., pp. 383-387.
- Sveum, P., C. Bech, and M. Thommasen. 1991. **Burning of Oil in Snow: Experiments and Implementation in a Norsk Hydro Drilling Contingency Plan.** In: *Proceedings of the Fourteenth Arctic and Marine Oilspill Program (AMOP) Technical Seminar*, June 12-14, Vancouver, BC. Environment Canada, Ottawa, ON, Canada, pp. 399-412.

CHAPTER 6. TECHNOLOGY OF IN SITU BURNING

6.1 Introduction

This chapter deals with the technologies available for in situ burning in ice-affected and open water. Much of the Arctic experiences an open-water season for some period of time, typically weeks to a few months each year. Specific pieces of equipment are documented in the categories of igniters, fire resistant containment booms, floating burners, and additives. The latter category includes ignition promoters, burn promoters, wicking agents and smoke suppressors. A special section has been included to describe the use of herding agents to contract slicks for burning in drift ice or open water without the need for fire booms.

Much of the technology discussed was conceived as a result of in situ burning attempts at specific spill incidents. For example, the *Torrey Canyon* incident in 1967 prompted considerable research on both sides of the Atlantic on the subjects of slick ignition and combustion promoters. The *Burmah Agate* and IXTOC-1 spill incidents in 1979 accelerated the development of fire-resistant containment booms, and the *Exxon Valdez* spill in 1989 started research on burning emulsions and the use of smoke suppression additives.

In recent years, efforts have shifted to the introduction of standard test protocols and a greater understanding of the processes involved in the ignition, steady burning, vigorous burning and extinction phases of in situ combustion. These advancements have fostered a greater acceptance of burning and a refinement of ignition equipment, fire booms and procedures for the controlled combustion of oil on water. The DWH response has already generated a new round of technological refinements and operational guidelines for open-water burning of oil.

6.2 Igniters

This section starts with a brief chronological history of the development of igniters. These discussions are followed by a more detailed presentation of commercially available igniter systems and some that are currently being considered for further test and evaluation. The section concludes with a review of igniters that were researched and in some cases manufactured, but are no longer available.

6.2.1 Brief History of Igniter Development

Many different ignition devices have been used over the years to ignite or attempt to ignite marine oil spills. In 1967 four attempts were made to ignite seemingly thick oil slicks on the sea near the *Torrey Canyon* using pyrotechnic devices containing sodium chlorate, but these attempts were unsuccessful (Swift et al., 1968; Anonymous, 1967). It was concluded that even though the spilled oil (Kuwait crude) had been on the water surface for only 40 minutes, it had emulsified to such an extent that it would not ignite.

Oil on the shore from the *Torrey Canyon* spill also proved virtually impossible to ignite and burn. Some success was reported in burning unemulsified oil in pools between rocks (Swift et al., 1968) using flame throwers to ignite pools. Emulsified oil could be burned on the beach as long as flame was applied directly to the oil. Once the flame was removed the combustion stopped.

Kontax was an igniter developed at the time by Edward Michels GmbH of Essen, Germany. It was demonstrated on a test spill off Holland where it successfully ignited and burned 10-tonnes of heavy Arabian crude (Freiberger & Byers, 1971; Energetex, 1978). The potential of Kontax was also demonstrated at the *Arrow* spill in 1970 where some of the spilled oil was primed with two drums of fresh oil and ignited with a Kontax igniter (Coupal, 1972).

Another igniter, Oilex Fire produced by Keltron Inc. of Switzerland consists of a sorbent (Oilex) plus a hydro-igniting agent. The company reported the chemical's use on small spills in Swiss lakes and in the Adriatic Sea (Freiberger & Byers, 1971).

On December 27, 1976, the *Argo Merchant* went aground near Nantucket Island and spilled most of its cargo of 28,450-tonnes of No. 6 fuel oil. Part of the response by the U.S. Coast Guard involved attempts to burn the oil. One 30-m x 40-m x 15-cm thick slick was treated with Tullanox 500 (a wicking/insulating agent), primed with 200-L (1.25 bbl) of JP-4 and ignited with JP-4-soaked cotton sheets set afire with a flare. About 95% of the Tullanox was blown off the treated slick by wind and the flames would not spread from the sheet to the primed slick. In another experiment, boxes of Tullanox 500 charged with JP-4 fuel were dropped onto a slick from a helicopter and ignited with timed thermite grenades. The isolated boxes burned but the flames did not spread (Det norske Veritas, 1979; Battelle, 1979).

On January 28, 1977, some 300,000-L (1900 bbl) of No. 2 fuel oil was spilled onto ice-covered waters in Buzzards Bay, Massachusetts from the barge *Bouchard* #65. Boxes of Tullanox soaked with jet fuel were dropped from helicopters onto pools of oil in the broken ice with delay-fuses. Thermite grenades were used to ignite the boxes. The ensuing fires burned for 1-1/2 to 2-hours and consumed 4,000 to 8,000-L (25 to 50 bbl) of oil. The 38 to 46 km/h (20 to 25-knot) winds drove the flames from pool to pool in areas nearby while in some areas the fires did not spread. Another series of burns were conducted at a later date, ignited with knotted rags soaked in diesel fuel (Schrier & Ediam, 1979; Ruby *et al.*, 1978).

Starting in 1977, considerable effort was devoted to developing an aerial ignition capability in support of potential spills from offshore exploration activities in the Beaufort Sea. Energetex Engineering evaluated and tested five devices (Kontax, Kontax with gasoline, solid propellant, solid fuel, and gasoline with sodium). Solid fuel and solid propellant igniters with a fuse wire were ranked highest (Energetex, 1978). Subsequently, two igniters were developed in Canada: the Dome igniter (Buist *et al.*, 1981; Energetex, 1982a and b) and the EPS igniter (Meikle, 1981a and b; Twardawa & Couture, 1983).

Laser-based ignition systems received considerable attention in the 1970s and 80s (Waterworth, 1987; Whittaker, 1987; Frish *et al.*, 1989; Laisk, 1976). A land-based system proved capable of igniting oil slicks on water (Frish *et al.*, 1989). The various components of a helicopter-borne system were researched under contract to Environment Canada and the Minerals Management Service; however, further development of the prototype system awaits private sector involvement and possible commercialization.

In Alaska, a forest-fire fighting tool known as the Helitorch was discovered in the mid-1980s to be an effective aerial ignition system for oil spills (Allen, 1986). Considerable testing and refinement of the device (Allen, 1987) has resulted in the Helitorch being stockpiled around the world as the igniter-of-choice for in situ burning.

Research efforts in the mid-1990s have looked at extending the capabilities of ignition systems to deal with water-in-oil emulsions (SL Ross, 1989; Bech *et al.*, 1992; SINTEF & SL Ross, 1993). In

this work, emulsions with up to 40% water content were successfully burned, however, higher-strength igniters using gelled crude oil, rather than the conventional use of gelled gasoline, were required for successful ignition. Further work by Guénette & Sveum (1995) used various gelled fuels (gasoline, diesel, and Bunker C), an emulsion breaker and an anti-foaming agent to successfully ignite and burn emulsions with water contents of up to 50%. The work showed the potential for the concept of a one-step break-and-burn process for igniting and burning emulsions. During trials off Lowestoft, England in 1996 (Guénette & Thornborough, 1997), the concept was demonstrated using a Helitorch to deliver the emulsion breaker and fuel mixture to successfully ignite and burn emulsions.

There has been little work done on aerial igniter development in the last two decades. The Helitorch is still stockpiled by some response organizations, and has been used in field trials such as the NOBE experiment in 1993 (Fingas *et al.*, 1994), the Lowestoft trials in 1996 (Thornborough, 1997), and two inland burns in Utah (Williams *et al.*, 2003). Other field trials and operational uses of in situ burning have used simple ad-hoc igniters. For example, during the response to the DWH blowout in 2010, in situ burns were initiated using igniters assembled from off-the-shelf components: a marine signal flare attached to a plastic bottle filled with gelled fuel (Mabile, 2010).

In addition, inland or marsh burns are commonly initiated using propane weed burners (May & Wolfe, 1997; Hess *et al.*, 1997).

The U.S. Navy Supervisor of Salvage (SUPSALV) undertook a programme to develop an igniter that did not require a helicopter to deploy and that could be shipped safely by surface or air transport (Moffatt & Hankins, 1997). Through an iterative process involving experimentation with different fuel compounds, a flare-type device was produced that could successfully ignite and burn diesel fuel and 25% water content emulsions. This unit was never commercialized.

The use of a sodium-silicon compound (NaSi) was examined by Buist (2005). Granules of sodium silicide were able to ignite slicks of fresh crude oil thicker than about 1-mm; however, the slicks extinguished before the oil (and the NaSi) was completely consumed. The NaSi granules remaining in the slick after extinction could pose concerns for residue recovery operations. Although the NaSi granules could ignite fresh crude, the short duration of the flames generated by the NaSi reacting with water, about 10 seconds, compared with several minutes for conventional ignition systems ranging from 2 minutes to 10 minutes burn time, raised questions about the ability of NaSi granules to ignite weathered oil slicks that need to be pre-heated to their Fire Point before ignition will take place.

Recently, Elastec and Desmi-AFTI have developed commercially available handheld ignition systems based on the technology used for ad-hoc igniters in the DWH response.

6.2.2 Presently Available Ignition Systems

There are several ignition systems that have proved to be effective and are either commercially available or can be constructed from technical designs. The discussion of these is divided into two sections: igniters for use from a vessel or from shore, and igniters for use from helicopters.

6.2.2.1 Surface-deployed Igniters

Both portable propane or butane torches, or weed burners, and rags or sorbent pads soaked in diesel have been used successfully many times in the past to ignite oil slicks on water. Experience has shown that propane torches tend to blow thin oil slicks away from the flames

and are best utilized on thick contained slicks. Diesel is the best fuel to soak sorbents or rags for use as igniters; gasoline results in a less powerful flame (Buist *et al.*, 1983a). A variation on this sorbent igniter was used at OHMSETT in the 1980s (Dome, 1981; Smith & Diaz, 1987). It involved sorbent wrapped around a short length of Ethafoam log, dipped in diesel or crude oil, and then sprayed with dimethyl ether (also known as starter fluid). This ignited easily and burned for a long time, even in choppy wave action.

Another successful surface-based igniter is gelled gasoline. Allen (1990a, and b) reports that the in situ test burn during the *Exxon Valdez* spill was ignited by a plastic bag containing gasoline gelled with "Surefire" gelling agent. The contents of the bag were mixed and, ignited by hand, and then released to the water from one of the fire boom tow vessels. The igniter was allowed to drift back into the contained oil in the towed U-boom configuration where it took several minutes to heat the oil to its fire point

The most commonly used igniter in recent experiments and in situ burn operations, including in the DWH response, has been the use of gelled fuel in combination with a marine distress flare (Mabile, 2010). The igniter can easily be assembled on-scene using off-the-shelf components. A flare is attached to a plastic container filled with gelled fuel and taped to floats that are consumed in the fire. When activated, the flare burns through the wall of the container, releasing its contents. The burning fuel then spreads out, pre-heating the surrounding oil, and igniting the contained slick.

Variations on the gelled fuel have been reported by Bech *et al.*, 1992; who mixed "Surefire" gelling agent with gasoline, diesel, and fresh crude oil. The flame temperatures measured by an infrared video system increased from gasoline to diesel to fresh crude. Further experimentation with other chemical additives such as ferrocene (for smoke reduction), anti-foaming agents and emulsion breakers has indicated that further improvements with gelled petroleum igniters may be possible (SINTEF & SL Ross, 1993; Guénette & Thornborough, 1997).

6.2.2.1.1 Safe Start Igniter

The Elastec/American Marine Safe Start Igniter (**Figure 6-1**) is designed to provide a safe and easy way to start Controlled Burns for oil spill control. Each 1 gallon (3.8 L) container is preloaded with non-toxic Safe Start gelling agent to be mixed with diesel fuel. A common marine flare, when ignited, will melt the container, allowing the gelled burning fuel to spread to an approximately 1-m diameter fire that lasts up to 5-minutes.



Figure 6-1 Safe Start hand-held igniter. (Source: Elastec / American Marine)

The Safe Start Igniter is produced and marketed by:

Elastec American Marine, Inc.
1309 West Main
Carmi, IL 62821
USA
Tel: 618-382-2525
Fax: 618-384-2740

6.2.2.1.2 AFTI Igniter

As a result of their experience during the DWH in situ burning operations, Desmi-AFTI has developed a simple hand-held igniter kit (**Figure 6-2**) that consists of a cardboard box containing two empty plastic gallon jugs, polyethylene foam packing, a ballast weight and a receptacle for a marine flare. The flare and fuel to be gelled (diesel or gasoline) are to be supplied by the customer. The gelling agent can be supplied either by Desmi-AFTI or the customer.



Figure 6-2 AFTI Hand-held Igniter. (Source: DESMI-AFTI)

The AFTI Igniter is produced and marketed by:

Desmi-AFTI, Inc. (formerly Applied Fabric Technologies, Inc.)
P.O. Box 575
Orchard Park, NY 14124
USA
Tel: 716-662-0632
Fax: 716-662-0636

6.2.2.2 Aerially-deployed Igniters

There are two aerially-deployed igniter systems that are currently available for use on oil spills, as discussed in the following section (adapted, with permission, from Allen, 1986).

6.2.2.2.1 Dome Igniter

The Dome Igniter (also known as the Energetex Igniter) is a lightweight, air-deployable pyrotechnic device developed by Dome Petroleum Ltd., Calgary, Canada, in cooperation with Energetex Engineering, Waterloo, Canada. The igniter (**Figure 6-3**) measures approximately

30-cm by 18-cm by 11-cm and weights a little over 0.4-kg. The unit consists of a wire-mesh fuel basket with solid propellant and gelled kerosene slabs suspended between two metal floats. Like the EPS igniter, the Dome unit is intended as a hand-thrown device.

The Dome Igniter was manufactured by Energetex Engineering and came to be known as the Energetex igniter or the "tin-can" igniter. It went through several design changes since it was first tested by Dome during the winter of 1979/80 (Buist *et al.*, 1981). These changes involved the igniter's mode of activation and the way in which certain components in its fuel basket are isolated from each other (Energetex, 1982b). In order to avoid any need for open flame during activation, the fuse wire is now started with a specially designed electric ignition system referred to as the Energetex Engineering Ignition System (EEIS). Consisting of a 12-volt spill-proof battery with a gel electrolyte and a heater element, the EEIS can provide sufficient heat to activate the igniter's fuse wire within two seconds of contact. Once started, the 25-cm long safety fuse provides about 45-seconds of delay for throwing the igniter and allowing it to settle within the target oil slick.

Although the Dome igniter is not in common use, it is still held in inventory by some response organizations and is included in this summary on that basis.

The fuse ignites a thermal igniter wire, which in turn ignites the solid propellant slabs located above and below the igniter wire. The solid propellant burns intensely for about 10 seconds with temperatures in excess of 1,200°C. During this initial burn, the gelled kerosene begins to burn, producing temperatures of 700°C to 800°C. The total burn time for the igniter is about 10 minutes.

The device is designed so that the fuel basket housing the propellant and gelled kerosene is suspended above the oil layer. Oil between the floats and beneath the fuel basket is somewhat shielded from the wind to allow heating of the oil. The relatively long burn-time for the Dome

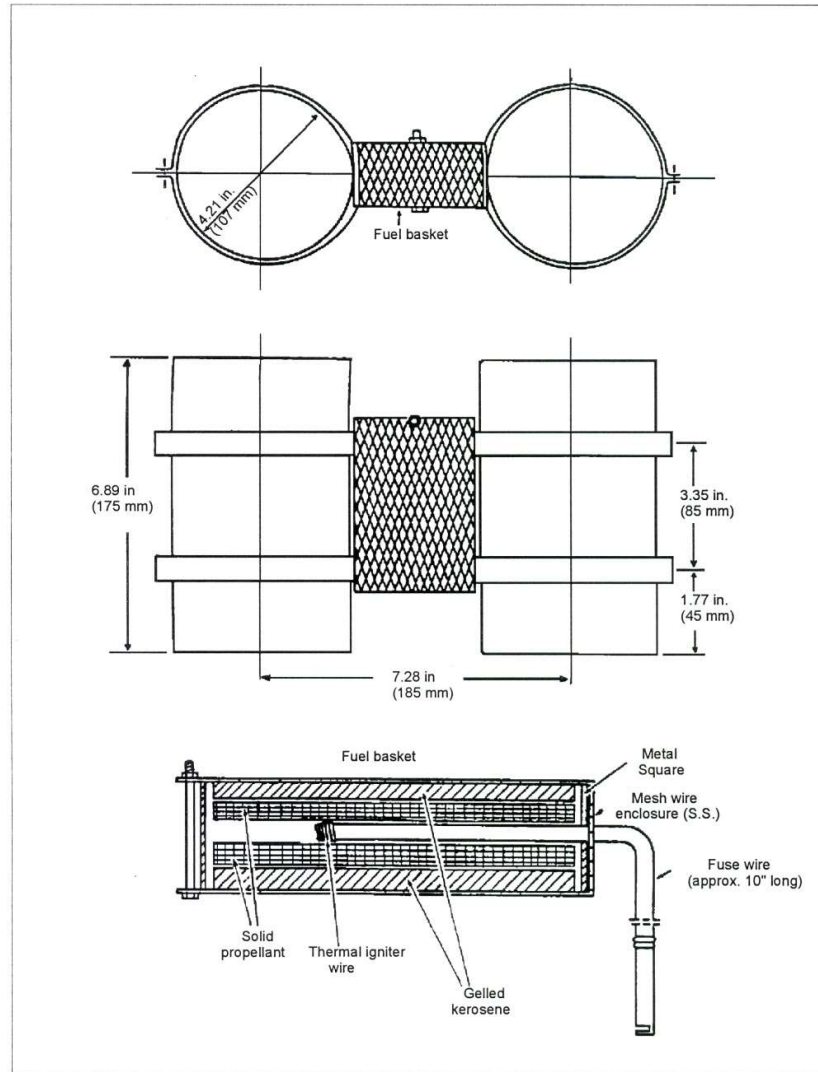

Figure 6-3 Basic design and internal components of the Dome or Energetex igniter (adapted from Allen, 1986). (Source: Marine Spill Response Corporation)

igniter helps get the slick lit if winds temporarily separate the igniter from the heaviest concentrations of oil. Upon completion of the burn, all of the metal components of the igniter remain on the surface of the water and attached to the two floats.

The low weight and irregular shape of the igniter give the igniter a relatively low terminal velocity and a tendency to avoid rolling on impact with solid surfaces. The igniter has only two stable positions in which it can float, and either one keeps the igniter's flames in close proximity to and slightly above the oil.

The fuse wire of the Dome igniter must be kept away from any potential sources of ignition. Once activated, the igniter cannot be deactivated, and it must be released as soon as possible (at least 20 to 30 seconds before the end of the 45-second delay period). Proper packaging in

separate plastic bags and storage of the units in cardboard boxes onboard the helicopter should be sufficient to prevent any accidental activation of an igniter.

Based on the Dome igniter's explosives classification it need only be stored in a spark-free, dry area and be packaged and properly marked as a pyrotechnic firework. The igniters should be stored in a secure place, safely removed from any heat sources and other flammable materials. The Dome igniter has undergone rigorous testing (Energetex, 1982b) involving a broad range of temperatures (-70°C to 50°C) and vibration and humidity conditions normally used for such explosives manufactured and used in Canada.

The simplicity of design of the Dome igniter provides a good probability of success. Its starter fuse and ignition wire have at least 95% reliability, and experience both in the U.S. and Canada suggests that the probability of activating the entire contents of the fuel basket is in excess of 90%. As with any pyrotechnic device, the probability of success is expected to diminish as the shelf life of each unit is approached.

The igniter has been extensively tested and shown to be capable of igniting fresh, weathered and emulsified oils (up to 60% water) in temperatures as low as -30°C and in winds up to 40-km/h (Dome, 1981b; Energetex, 1978, 1979, 1981a, 1982b).

The shelf life of the Dome igniter is estimated at about five years, although experience with igniters stored in Alaska and Canada has shown that they will operate after 15 to 25 years (Allen, 1992; SL Ross *et al.*, 2003). It is important that any stockpiled igniters be carefully dated, periodically tested and reconstructed as necessary. It is estimated that tearing down and replacing the pyrotechnic portion of the igniter will cost approximately 50% of the original purchase price.

The current manufacturer of the Dome igniter is:

Energetex Engineering
505-125 Lincoln Road
Waterloo, Ontario, Canada, N2J 2N9
Fax: 519-885-2738

6.2.2.2.2 Heli-Torch

The Heli-torch (**Figure 6-4**) is a proven aerial ignition system commonly used by the U.S. Forest Service and the Canadian Forestry Service for burning forest slash and for setting backfires during fire-control operations. It is a completely self-contained unit consisting of a fuel barrel, pump, and motor assembly slung beneath a helicopter and controlled with an electrical connection from the Heli-torch to a panel in the cockpit. The fuel barrel can be filled with a gelled gasoline or gasoline and diesel mix which is then pumped on demand to a positive-control shut-off valve and ignition tip. The gelled fuel mixture is ignited with electrically-fired propane jets as it exits one or more nozzles protected by wind shields. The burning gelled fuel falls as a highly viscous stream and quickly breaks up into individual globules before hitting the ground. Three models are available with 110-L, 205-L and 1100-L (0.7, 1.3 and 7.0 bbl) capacities. Of these, the 205-L (1.3 bbl) model has been most extensively tested for use on oil spills.

In fighting forest fires, the Heli-torch may be operated from heights of several hundred feet and with speeds of 40 to 60 mph (65 to 95 km/h). As discussed in this report, such heights and airspeeds are not desirable for the ignition of oil slicks at sea. Depending upon the actual nature of the slicks to be ignited, flying at much lower altitudes (8 to 23-m) and with airspeeds of 40 to 50 km/h may considerably enhance the accuracy, ignition success and distribution of burning globules.

The Heli-torch ignition system is manufactured by Simplex Aerospace Co. in Portland, Oregon (www.simplexmf.com), and is approved by the U.S. Federal Aviation Administration (FAR Part 137). U.S. users of the system are cautioned that certain federal regulations (46 CFR) require approval by the Office of Hazardous Materials Transportation (OHMT), U.S. Department of Transportation, for transporting fuel beneath a helicopter (e.g., sling-loaded Heli-torch) and for transporting the fuel to support a gelling operation at a remote site. Exemptions from these requirements have been obtained for such operations as forest fire control; nevertheless, application for exemption involving oil spill control must be requested.

The Heli-torch can be carried by a helicopter with a cargo hook and a 24-to 28-volt power supply. When the single-point suspension cable system is used with helicopters employing swivel cargo hooks (e.g., Bell 250, 212, 412), the Heli-torch may experience temporary rotation. However its design normally allows the unit to achieve a stable orientation and fly without any loss of its globule-ignition or distribution characteristics.

Depending upon the helicopter used (i.e., with fixed or swivel cargo hook), the Helitorch support assembly may be rigged to include a self-releasing horizontal support arm or stabilizing bar to keep the Heli-torch oriented properly. The stabilizing bar can be suspended at one end directly below the cargo hook, with the other end of the bar resting on one of the helicopter's skids. The Heli-torch's support cable assembly is then connected directly to the stabilizing bar. This approach provides a stable two-point connection while permitting the Heli-torch to be jettisoned if necessary. Both support systems (i.e., with and without the stabilizing bar) were used during field trials described in Allen (1987).

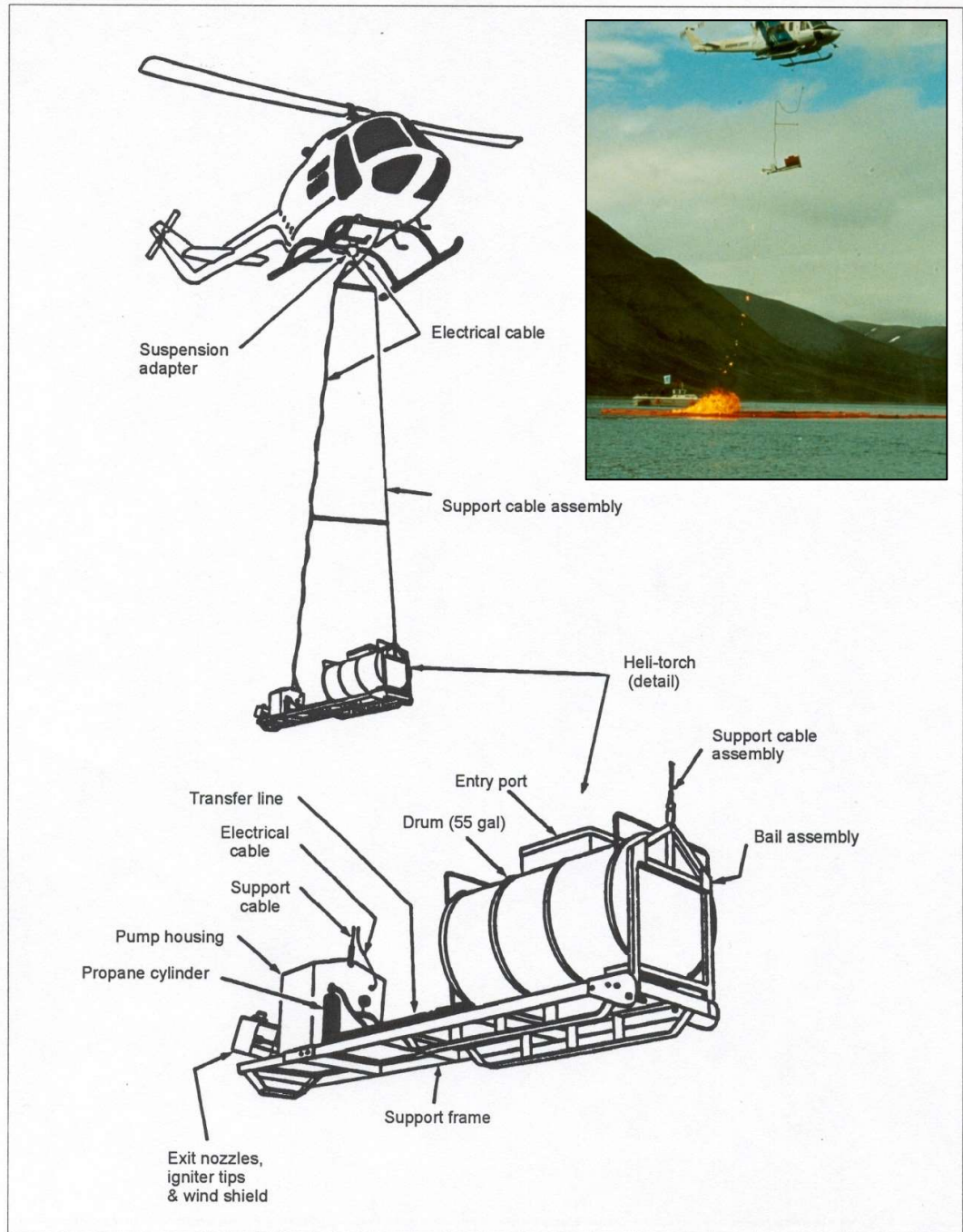

Figure 6-4 Heli-Torch Components and Support System (adapted from Allen 1986). (Source: Marine Spill Response Corporation; photo: A. Allen)

The weight of the Heli-torch with a full 205-L (1.3-bbl) drum is approximately 243-kg (534 pounds). The entire unit is connected to a helicopter with a support cable assembly that can be

jettisoned quickly from the helicopter's cargo hook. The electrical cable has a quick-disconnect plug near the helicopter, and this plug can also be pulled apart easily if the unit is released in an emergency.

The gelling mix used to thicken the gasoline (or diesel as the case may be) often involved SUREFIRE, a gelling agent available from Simplex (Portland, Oregon) and from Fire-Trol Holdings, L.L.C. (the exclusive U.S.A. distributor for FIRE-TROL Fuel Gelling Agent, previously sold as SUREFIRE®). SUREFIRE is a fine powder that when mixed with liquid fuel produces a smooth, viscous gel. When typical ratios of 1.8 to 2.8-kg (4 to 6-pounds) of SUREFIRE to 205-L (1.3-bbl) of fuel are used, adequate viscosities for Heli-torch use can normally be achieved within a matter of minutes at room temperature. At sub-freezing temperatures, ratios of 5-kg (11-pounds) to 205-L (1.3-bbl) are required for gelling to occur in 30 to 40-minutes. The gelling mix is poured through the entry port of the Heli-torch fuel storage drum, which is equipped with a hand crank for mixing. Separate, portable gelled fuel mixing tanks are available from the manufacturer.

The Heli-torch is operated with a positive-displacement pump producing a flow of approximately 55 L/min. When operated with a 205-L (1.3-bbl) holding drum, the Heli-torch can provide a total application time of about 3-minutes and 40-seconds. The drum would then have to be refilled with gelled fuel or replaced with another drum already filled. The 205-L (1.3 bbl) Heli-torch model is rigged so that an empty drum can be removed from the support frame and replaced with a full backup drum quickly and safely.

Burning gelled gasoline globules released from heights of a few metres to 18-m continue burning after impact. Even without oil on the water's surface, splash effects are tolerable, and elongated "pancakes" of gelled burning fuel result with sizes (if expressed as a circle) typically 13 to 18-cm in diameter.

Experience suggests that the average globule sizes produced by the Heli-torch with its standard nozzle at heights of 20-m or less will be between 60 and 120-mL. With gelling-mix-to-gasoline ratios of 2.5 to 5-kg per 205-L (1.3 bbl) of fuel, such globules spread to thicknesses of 6 to 8-mm on oil-free water surfaces. The globule burn times range between 4 and 6-minutes.

Ignition of fresh and 2-week weathered, unemulsified crude oil layers is possible in winds of 15 to 25 km/h; globules approximately 60 to 120-mL in volume are necessary to prevent blowout of the flame. During several successful ignitions of crude oil layers, surface winds have reached speeds of 30 km/h.

Experience (Allen, 1992) has shown that the Heli-torch should be flown at altitudes of 8 to 23-m and with speeds of 40 to 50 km/h. The suggested altitude range is to provide accuracy during the release, to reduce the loss of gelled fuel while burning in the air, and to prevent the blowout of smaller globules on the surface by downwash when the helicopter is flying at low speeds. A minimum speed of 40 km/h is recommended to prevent such blowouts. At altitudes in excess of 30-m downwash is minimal and the Heli-torch can be used in a stationary mode.

It should be noted that some jurisdictions/operators now restrict the use of Heli-torch and other helicopter-slung devices, notably Norway.

The manufacturer of the Helitorch (see below) also offers a land-based version called the Groundtorch (Allen, 1987). The device consists of a storage drum and pump connected to a hand-held "wand" for application of the burning gelled gasoline. The systems are commonly used from a pickup truck or a small trailer for the ignition of backfires and slash piles.

SUMMARY: Table 6-1 gives a summary comparison of the two aerial ignition systems discussed above.

Table 6-1: Summary of Igniter Characteristics and Performance			
ASSESSMENT CRITERIA		DOME IGNITER	HELI-TORCH (205-L MODEL)
SAFETY	Open flame or sparks inside aircraft	None, if EEIS used	None
	Susceptibility to accidental activation	Highly unlikely (requires separate ignition source)	Unlikely (positive off/on control and isolated circuit breaker)
	Retrieval and handling of igniters that have misfired	Safe to handle after 2-min. delay	Must return to base to adjust/repair/replace Heli-torch
STORAGE	Shelf life	5 years (Dome igniters stored 25 to 30 years in Arctic still operating)	N.A. (Flammable mixture prepared at time of need)
	Difficulty of replacement (all or in part) following normal shelf life	Simple replacement of pyrotechnic portion only (about 50% of initial <cost)	N.A.
	Routine maintenance requirements	None	Minimal (pump, valves, stirring equipment, etc.)
	Susceptibility to high or low temperatures during storage/transit	Very low (tested between -70°C and +50°C)	Gel-mixing process best carried out at or above freezing temperatures
	Susceptibility to vibration or humidity during storage/transit	Very low (meets military requirements)	Vibration No problem. Must keep fuel free of water prior to and during mixing.
GOVERNMENT REGULATIONS	Shipping and storage regulations	Basically treated as fireworks. Housed and locked in non-sparking container, properly marked as fireworks. Shipment by land, sea or chartered aircraft permitted; shipment by commercial passenger aircraft prohibited.	Subject to same storage and transit requirements as for petroleum products. Cannot fly Heli-torch over populated areas (FAR Part 137 approved)
AVAILABILITY	Currently stockpiled	Approx. 1,700 igniters at Prudhoe Bay (owned by Alaska Clean Seas); approx. 4,000 igniters at Tuktoyaktuk, Canada (owned by Canadian Coast Guard)	Numerous units available in U.S. and Canada
	Resupply capability	No longer produced by Energetex	Under emergency conditions, approx. 20 Heli-torches per month
COST	Estimated cost	No longer produced by Energetex. Cost \$80 to \$120 (depending on volume purchased) per unit in 1986	Approx. \$15,000 per application unit.

Table 6-1: Summary of Igniter Characteristics and Performance			
ASSESSMENT CRITERIA		DOME IGNITER	HELI-TORCH (205-L MODEL)
OPERATIONAL CONSIDERATIONS	Level of field testing performed to date	Extensive. Many controlled spills and some actual spills	Extensive experience on land. Moderate experience with fresh oil on water
	Reliance upon unique airborne application device	None	Yes. Heli-torch frame and pump assembly
	Igniter (and/or application system) preparations – from storage to field use	None	Minor setup. Self-contained package quickly prepared and sling-loaded. Need mixing operations on ground for support
	Average rate of application	Approx. 3 to 6 per min.	Burning globules (golf ball to fist size) over a swath 3-m wide; typically about 2-km runs per sortie at 40 to 50/h and at 15-m altitude or less
	Approximate number of igniters releasable per helicopter sortie	Several hundred depending on helicopter selected and ability to setdown for transfer of cargo and passenger area	Thousands of 60 to 120 mL globules
	Accuracy of deployment on target oil slick	Excellent. Irregular shape prevents rolling. Low drift while airborne	Random distribution of burning gel over target area
	Durability (or resistance to damage during impact)	Good. Designed for typical drop heights of 15 to 30-m onto frozen surface	Burning globules flatten out on impact with water
OTHER	Performance in shallow pools (less than 4 in. deep) on solid ice	Good. Shallow draft	Good
	Dependence on orientation for proper performance	Either of 2 stable, floating positions	N.A.
	Nature and orientation of flame during ignition of oil	Hot, initial flame then soft, billowy flame concentrated over oil/water surface between floats	Soft flame from gelled fuel globule: 15-cm diameter
	Splash effects during impact with oil and water	Significant, though oil layers greater than 1/10 in. quickly become re-established around igniter	Minimal, does not extinguish flame
	Temperature and duration of heat source	More than 1200°C for 10 seconds followed by 700°C to 800°C for approx. 10 minutes	Approx. 800°C for up to 6 minutes
	Reliability of starter	Typically greater than 95%	Unknown, but high

Table 6-1: Summary of Igniter Characteristics and Performance

ASSESSMENT CRITERIA		DOME IGNITER	HELI-TORCH (205-L MODEL)
	Reliability of igniter	Typically greater than 90% (begins to drop after 5-year shelf life)	Unknown, but high
	Sensitivity to temporary submergence upon impact	None	Extinguishes
	Sensitivity to wind, rain and sea state during ignition	Blowoff wind velocity > 40 km/h., insensitive to rain, unknown sensitivity to waves	Blowoff wind velocity for small globules < 10 km/h.; for larger globules > 30 km/h; insensitive to rain; unknown sensitivity to waves (successful with slightly weathered oil in 0.6-m waves)
	Type and amount of debris after use	Entire metal float package and fuel basket survive fire and remain on water surface	No debris
	Training requirements	Minimal (about 10 min.) Experience needed in identifying and hitting appropriate targets	Moderate training both for operation and mixing fuel

6.2.3 Fixed-Wing Aerial Ignition System

The ignition of spilled oil from a fixed-wing aircraft has some significant advantages over hand-held igniters and the use of the Helitorch. Primary advantages include the ability to carry much larger payloads, typically approaching 3784 L (24 bbl) of gelled fuel, and to deliver such payloads many tens to hundreds of miles from a staging area. A series of “Proof-of-Concept” ground tests (Preli *et al.*, 2011) were conducted in 2010 and 2011 to determine whether gelled fuel could be ignited and achieve a sustained burn at release speeds of 80 to 100-knots, corresponding to the speed of a small fixed-wing aircraft. The tests were conducted at the Beacon Training Center in Kenai, Alaska.

Numerous tests were conducted with a variety of nozzle/shroud configurations at temperatures between 7°C to well below freezing using a trailer-mounted wind machine to simulate the release of various mixes of gelled fuel (gasoline, diesel, and aviation gas) gelled with Flash 21 gelling agent. The nozzle/shroud configurations were tested under a variety of orientations downwind to reduce the relative velocity of the burning gelled fuel globules within the wind-induced (aircraft-simulated) air. Over two separate week-long test periods the results demonstrated the feasibility of igniting gelled fuel at simulated fixed-wing aircraft speeds approaching 110 knots.

The safe and effective aerial application of gelled fuel far offshore with large payloads and high delivery speeds could significantly enhance the ability to conduct controlled burns should spilled oil be spread over a large and remote area, with or without ice.

6.2.4 Summary of Disused Ignition Systems

The following ignition systems had been used or were researched at one time but are no longer available, recommended, or considered for use.

6.2.4.1 EPS igniter

The Environmental Protection Service (EPS) Igniter is an air-deployable pyrotechnic device developed by the Canadian Environmental Protection Service, a division of Environment Canada, in cooperation with Canadian Department of National Defence Research Establishment, Valcartier (DREV) and the Arctic Marine Oilspill Program (AMOP) (Twardawa & Couture, 1983). The igniter (**Figure 6-5**) is approximately 25-cm square and 13-cm high and weighs nearly 2-kg. The unit consists of a pyrotechnic device sandwiched between two layers of foam flotation and is activated by a self-contained firing mechanism. It is intended to be a hand-thrown device.

The EPS igniter was marketed in the past as the "PYROID" igniter manufactured by ABA Chemical Ltd., but the company is no longer in business. Although the device is not commercially available, the design is available from Environment Canada's Emergency Engineering Division.

The device is simple in design and operation, being activated by pulling on a firing clip which in turn strikes a primer cap. A 25-second delay column then provides sufficient time to throw the igniter and let it settle within the target oil slick. A specially formulated ring of fast-burning ignition composition is then ignited, and this in turn ignites the primary incendiary composition. The incendiary composition is a solid propellant consisting of typically 40% to 70% ammonium perchlorate, 10% to 30% metal fuel (magnesium or aluminum), 14% to 22% binder, and small amounts of other ingredients to aid in the casting and curing processes. These materials have an estimated shelf life of about 5 years.

The firing mechanism and the incendiary materials are sandwiched between two polystyrene foam slabs to provide both buoyancy and protection for the device on impact. All components except the firing mechanism are combustible, so that very little debris is left in the environment after a burn. These components have also been designed so that the igniter experiences a minimum of roll if dropped onto a hard surface (like ice) or shallow water. The igniter can float in as little as 5-cm of water/oil. The flame it produces will be oriented properly regardless of which side of the igniter is up. The EPS igniter has been designed to produce a ring of fire with temperatures approaching 2000°C immediately adjacent to the perimeter of the igniter. This intense flame has a typical duration of about 2 minutes.

The EPS igniter has been designed so that no open flames or sparks are experienced aboard the deployment helicopter. Once the igniter is activated, however, there is no way to deactivate the igniter -it must be thrown from the helicopter within the 25-second delay period. Prior to the

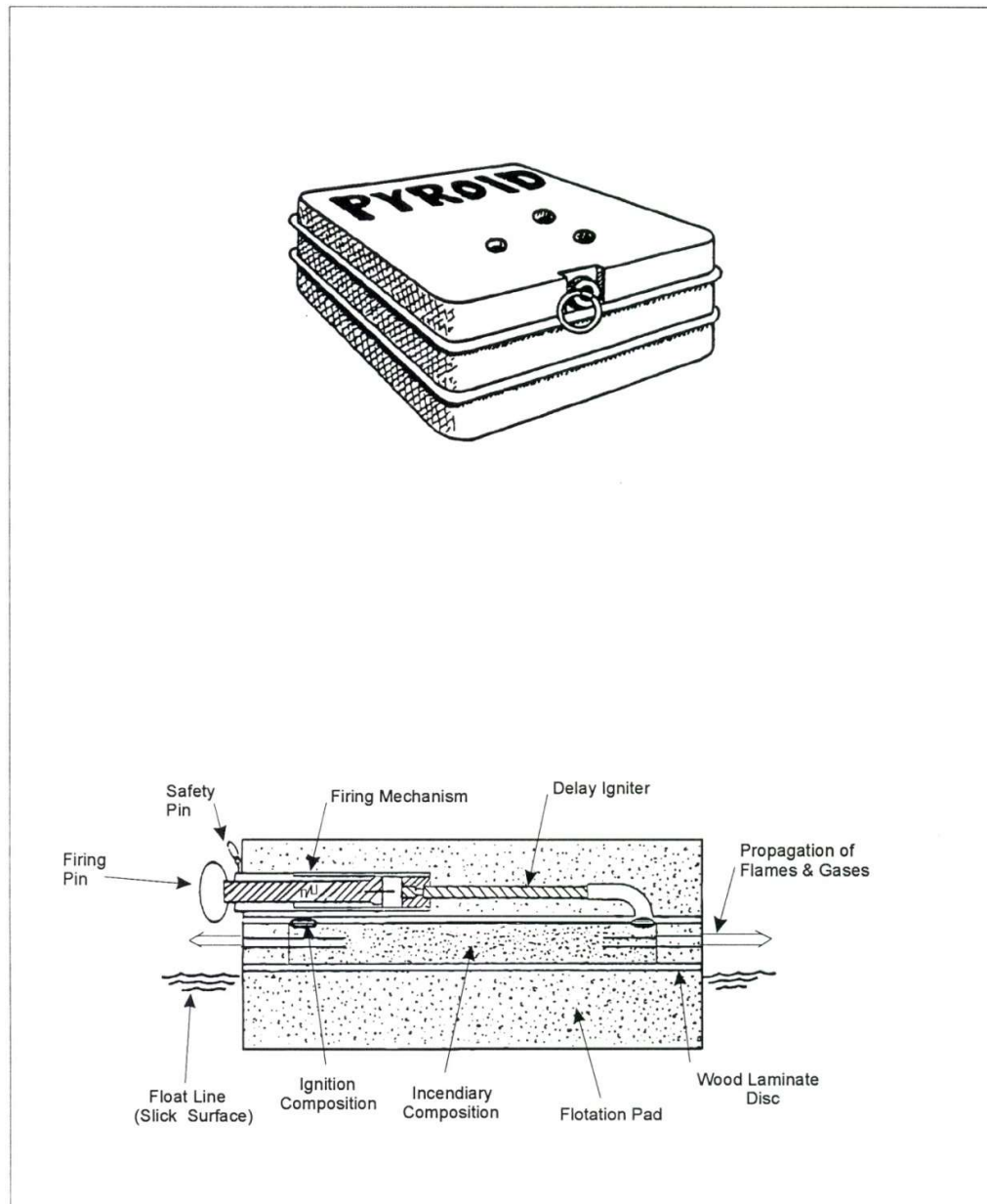

Figure 6-5 Environmental Protection Service (EPS) igniter, or Pyroid igniter, showing internal firing mechanism and pyrotechnic components (adapted from Allen 1986). (Source: Marine Spill Response Corporation)

activation, there is very little chance of an accidental firing because there is a safety pin in the firing mechanism.

The EPS igniter was designed to provide a 75% probability of functioning properly when dropped at an airspeed of about 30 km/h from an altitude of approximately 15-m. Actual field tests indicate that a high probability of success can be achieved with newly constructed devices

but as the 5-year shelf life is approached, the probability of functioning properly begins to drop off. It is therefore important that stockpiled igniters be carefully dated and then reconstructed as their shelf lives expire. The cost of tearing down and replacing the pyrotechnic portion of the igniter is estimated to be about 25% of the original manufacturing price. The plans for the EPS igniter may be obtained from:

Emergencies Engineering Division
Environment Canada, Conservation and Protection
River Road Environmental Technology Center
3439 River Road Ottawa, Ontario, Canada, K1A 0H3
Fax: (613) 991-1673

6.2.4.2 Kontax

The Kontax igniter was produced by Edward Michels GmbH of Essen, Germany. Production of the device ceased in the mid-to late-1970s (Energetex, 1978). The device consisted of a 4-cm diameter cylindrical metal screen 30.5-cm long and capped at both ends. A metal bar coated with metallic sodium ran through the center of the cylinder. The annulus was filled with calcium carbide. The device weighed 1.2-kg. For safety reasons the Kontax igniter was stored in a sealed plastic bag.

The Kontax igniter had a unique feature: it did not require activation or a starter. When the device was exposed to water the sodium metal reacted to produce heat and hydrogen, which instantly ignited. At the same time the calcium carbide reacted with water to produce acetylene which was subsequently ignited by the burning hydrogen. The flame from the burning acetylene preheated and ignited oil vapours.

Tests to evaluate Kontax were conducted in 1969 by the Dutch government (Battelle, 1979). The tests were conducted 25 miles offshore and on beaches; the oils used were heavy and light Arabian crude. The Kontax used was in 25-kg bags. One test involved a 9-tonne slick covering about 2000-m² (0.5-cm thick) in a free-floating lumber boom. The bags containing the Kontax were punctured and thrown into the slick. The igniters were successful; flames of 15 to 20-m high were reported and 98 to 99% oil removal efficiency was estimated. A Kontax-to-oil ratio of 1: 100 by weight was judged to be appropriate.

Tests with the Kontax igniter (Energetex 1978) showed that it produced a large flame area (3000-cm²) with a relatively low flame temperature (770°C). This combination produced a relatively high flame emissivity of 2.25 kW/m². Although Kontax proved effective in both field and tank trials as a surface-deployed igniter (Freiberger & Byers, 1971; Energetex, 1978), the device proved less effective when dropped from a height of 11.5-m, simulating deployment from a helicopter. Ignition success rate declined from 100% in the surface tests to 60% in the aerial tests. The main reason for the latter result was that the large splash caused by the Kontax igniter entering the water drove the oil away; by the time the oil had returned, the igniter had generated a ring of calcium hydroxide foam that kept the oil away.

Energetex (1978) tested a modification to the Kontax igniter, which involved combining a small amount of gasoline with the device. This inclusion of gasoline was intended as a fuel to bridge the calcium hydroxide foam barrier. This modification resulted in a slightly higher flame temperature (790°C) and better aerial deployment ignition success (80%).

It is not clear why Kontax was taken out of production. It may have been due to a general lack of interest in in situ burning at the time, or due to the potential dangers and stringent requirements for storing, transporting, and using the igniters.

6.2.4.3 Solid Propellants

Solid propellants, also known as solid rocket fuels, are composed of a solid mixture of various portions of ammonium perchlorate oxidizer, metal fuel (magnesium or aluminum), and an organic binder. They have been used in a variety of igniters. Solid propellant igniters, in various shapes and utilizing various starters (electrical, chemical or fuses) have been extensively tested (Energetex, 1978). Such igniters exhibit very high flame temperatures (about 1230°C) and high flame emissivities (1.75 kW/m²) but are consumed rapidly. They require mounting in a housing to suspend them no more than 5-cm above the oil/air interface. In water surface tests, solid propellant gave an 89% ignition success rate; and an 80% success rate in aerial-deployment tests with a fuse-wire starter (all other starter mechanisms resulted in lower success rates).

Solid propellants were once considered, but now are not recommended for use alone as an oil spill igniter. Rather, they and solid fuels (discussed next) are used in conjunction with other components in currently available igniter systems.

6.2.4.4 Solid Fuel

Solid fuel igniters employ gelled kerosene cubes (e.g., solid barbecue starter) suspended above the oil/air interface. Because of the lower flame temperatures (770°C) and flame emissivities (0.5 kW/m²) generated, it is necessary to suspend the cubes within 3-cm of the oil surface in order to successfully ignite oil. Surface ignition tests have given an 84% success rate while aerial tests have resulted in an 80% success rate using a fuse wire starter (Energetex, 1978). Solid fuel is used in one commercially available oil slick igniter discussed in the following section.

6.2.4.5 Thermite

Thermite is a mixture of metallic aluminum powder and ferric oxide. Although producing extremely high temperatures (about 3500°C) the mixture requires a very high ignition temperature (about 2000°C) which necessitates specialized starters. Military incendiary devices utilise thermite.

Although thermite has been used with some success at several spills, as noted earlier, it is no longer recommended as an oil spill igniter due to its stringent storage and transport requirements.

6.2.4.6 Marker Flares

A number of types of marker flares have been considered or used as oil slick igniters. These include both road and marine flares of the phosphorous, calcium hydroxide, and magnesium types. They can be successful in igniting fuels at temperatures above the fuel's flash point or in igniting a primer liquid placed on a sub-flash fuel (Freiberger & Byers, 1971). They are not effective in directly igniting sub-flash oils (Energetex, 1978).

6.2.4.7 Proprietary Ignition Chemicals

Two proprietary ignition systems have been reported in the literature (Cabioc'h, 1993). These are Westcom 2000 and Westcom 2001 (also known as Westcom II and III respectively). Westcom 2000 is a coarse granular mixture incorporating a hydro-igniting chemical and oxygen donation

catalyst. It is contained in a sealed plastic bag that must be cut before being thrown onto the slick.

Westcom 2001 is a viscous colourless gel intended to be sprayed on the surface of an emulsified slick to ignite it and promote its combustion, with initial ignition provided by Westcom 2000. Experience with the product indicates that it offers only a small advantage over gelled diesel fuel and the on-site mixing and spraying is cumbersome. Furthermore, it has been noted that the use of Westcom 2001 reduces the capacity of sorbent pads on the residue that remains after a burn (Cabioc'h, 1993). Although the product has been tested successfully in both temperate and Arctic elements the current view is that it should not be considered for use, primarily because of safety concerns regarding the storage and handling of such hydro-igniting chemicals on vessels or aircraft.

6.2.4.8 *Hypergols*

Hypergols consist of two liquids stored separately; one is a strong oxidant (such as fuming nitric acid) and the other is combustible. When mixed, they burn rapidly, particularly when the oxidant provides its own oxygen. These have been considered for use as oil spill igniters, but are currently rejected because of the dangers in storing and mixing the reagents (Energetex, 1978).

6.2.4.9 *Sodium and Gasoline*

Tests were done on an igniter consisting of a small plastic bag filled with gasoline connected to a wire enclosure containing a piece of metallic sodium (Energetex, 1978). The device was unsuccessful during surface tests because the sodium failed to ignite the gasoline. This occurred for two reasons: sodium coated with gasoline or oil does not react vigorously enough with water; and, the sodium tended to escape from its container. Storage and handling problems would also be anticipated with this type of device. Tests conducted in 2004 with a slurry of metallic sodium and kerosene produced similar results (SL Ross, 2004).

6.2.4.10 *Premo Aerial Ignition Device (AID)*

The Premo AID is a system designed for the ignition of debris and backfires in forest fire control. The ignition component of the system consists of 3-cm diameter polystyrene spheres each containing approximately 3-grams of potassium permanganate. The igniter is started by injecting the cylinder with 1 mL of glycol. A highly exothermic reaction is initiated which results in combustion of the device and its contents for a period of 20 to 30-seconds. Flame size and ignition delay are varied by changing the grain size and mass of potassium permanganate, and by diluting the glycol with water.

The delivery component of the AID system consists of a mechanical dispenser comprising a storage hopper, injection chambers and exit chutes. The polystyrene balls are mechanically fed into the injection chambers, injected with glycol and then immediately ejected into the exit chute. The dispenser also contains a water reservoir and fire extinguishing system should a ball jam after injection. The dispenser is designed to be strapped to the floor of a helicopter, extending out the open rear door. The device is equipped with tie down straps and a break-away electrical connection so it can be quickly jettisoned in an emergency.

When this device was tested for use as an oil spill igniter (Allen, 1987), it was found that the igniter was easily extinguished when water was splashed on the burning ball.

6.2.4.11 Lasers

The use of lasers mounted in helicopters to ignite oil spills received considerable attention in the late 1970's and 1980's (Laisk, 1976; Frish *et al.*, 1986; Waterworth, 1987; Whittaker, 1987; Frish *et al.*, 1989). In static tests on land the concept proved to be capable of igniting fresh and weathered unemulsified oil in 1-m² pools on ice (Whittaker, 1987). Engineering studies to develop or source the various components of a helicopter-based system were completed but a commercial prototype was not developed.

6.3 Fire Resistant Containment Booms

6.3.1 Brief History

The effectiveness of burning thick oil slicks has been noted in **Chapter 4**. Removal efficiency increases with increased initial thickness, as does burn rate. In order to thicken and contain oil spills for burning, a variety of fire-resistant booms have been developed over the years.

Efforts in North America to develop fire resistant booms began in 1976 with work on spray and air bubble barriers for containing burning oil from sub-sea blowouts (Purves, 1978; Comfort *et al.*, 1979; Purves & Daoust, 1978). These were found to be impractical because of the poor efficiency of air bubble barriers and the operational complexity of water spray barriers. At about the same time and for the same application, work was begun on the development and testing of a "quickie" boom that could be constructed with empty steel oil drums and fire blanket (McAllister, 1979). The device was tested in a small pond and proved reasonably effective at containing oil burning on water.

In 1979, three large spills catalyzed renewed efforts to develop fire resistant containment booms: the IXTOC-1 blowout, the *Burmah Agate* spill and the sinking of the *Atlantic Empress*. The IXTOC-1 offshore blowout illustrated the difficulties associated with dealing with large quantities of oil discharged continuously over a long period of time (Ross *et al.*, 1979). This very large spill (some 500,000-m³ in total) also highlighted the potential of in situ burning for dealing with such fixed-point spills. The *Burmah Agate* spill, which released 250,000-bbl of oil into the Gulf of Mexico in November, 1979, illustrated again the potential for in situ burning to remove large amounts of surface oil (186,000-bbl burned or 74%) and highlighted the need to develop fire resistant booms to contain burning oil (Kana *et al.*, 1981). The *Atlantic Empress* incident, in which all the oil released from the burning and sinking of a 288,000 dwt tanker was consumed in a fire, further illustrated the potential for in situ burning to remove oil from the sea surface (Horn & Neal, 1981).

Following these spills, from 1979 to 1981, Dome Petroleum Ltd., the main explorer for offshore oil in the Canadian Beaufort Sea, researched and developed a heavy-duty stainless steel fire resistant boom for long term offshore use (Buist *et al.*, 1983b). This test programme involved field testing of various prototypes at the OHMSETT facility in New Jersey, and at locations in British Columbia and Nova Scotia. Shortly thereafter, efforts were underway in Alaska to develop lighter fire-resistant booms for short-term use (Industry Task Group, 1983; Allen, 1986a), and in Canada to develop lighter, lower cost boom designs (Meikle, 1983). Some work also continued with an air-bubble boom concept (Williams & Cooke, 1985) and a water spray concept (Comfort, 1989).

The Alaskan work resulted in the development of the 3M Fire Boom. In July 1988, a field test of 3M Fire Boom was carried out in a fjord at Longyearbyen, Svalbard, Norway. The trials involved 90-m of boom and 1900-L (12-bbl) of Statfjord crude. Unweathered oil in the pocket of the boom was ignited with a Heli-torch and burned for approximately 30-minutes (Allen, 1992).

In 1989, the *Exxon Valdez* went aground on Bligh Reef in Prince William Sound, Alaska and released 41,000-m³ of crude oil. During the evening of the second day following the accident an estimated 57 to 114-m³ of slightly emulsified (20 to 30% water) North Slope crude was burned in situ using 136-m of 3M Fire Boom (Allen, 1991a). This was the first recorded use of manufactured fire-resistant boom at a major spill incident. The burn was initiated using a floating bag of gelled gasoline. The burn lasted 75 minutes, of which 45 minutes involved intense burning and flames reaching 60 to 90-m into the air. Residue remaining in the boom after the burn was about 1.1-m³ of stiff, taffy-like material (Allen, 1991b). By the time additional burns were attempted, a storm had further emulsified the slick rendering it unignitable (Exxon, 1990).

On August 12, 1993 two experimental burns were conducted offshore of St. John's, Newfoundland that involved 3M Fire Boom. The 210-m of boom survived the first 1.5-hour burn in 50-cm waves with 8 to 11 km/h winds; it was then examined and, despite some signs of fatigue and self-abrasion, was considered acceptable for another burn. Seventy-five minutes into the second burn several flotation units were lost from one section of the boom and it began to leak oil. The test was stopped and the boom re-examined. Preliminary on-site results indicate that self-abrasion of the fire resistant fabric had occurred (Raloff, 1993; NOBE Facts, 1993; OSIR 19 August 1993).

Although the main objective of this landmark experiment in 1993 was to document the emissions from an in situ burn, there were observations of boom performance that are useful (Fingas *et al.*, 1994). Oil was contained in commercially-available American Marine fire-resistant boom (aka 3M fire-boom) and ignited using a Heli-torch. After the first burn of 48-m³ of crude oil, over a period of 90-minutes, some fatigue was noted in the stainless steel core of the boom and some portions of the fire-resistant fabric were missing. The boom was judged to be fit for a second burn. After the second burn of 29-m³ of crude oil, over a period of 80-minutes, a prototype section was found to be missing its float logs; subsequent inspection showed that it had not been properly constructed. The boom was judged to be in good overall condition but one would not have used the apex for another burn.

Lazes (1994) reported on their company's in-house development and testing of an inflatable fire-resistant boom. The aim of the testing was to characterise the heat flux from crude oil fires and evaluate different insulating materials. Various ceramic materials were used to resist the effects of heat, however they were found to suffer from embrittlement and were susceptible to failure after heat exposure and when subjected to tensile loading. Tubes were added to the boom to allow air circulation over the exposed surface of the boom and were found to reduce the heat load by up to 25%.

The U.S. Coast Guard R&D Center and the U.S. Department of Interior Minerals Management Service (now called BSEE) jointly sponsored a series of oil containment tests of five fire-resistant booms using the OHMSETT facility (Bitting & Coyne, 1997). The tests were performed using the standard OHMSETT test procedure for containment boom testing, which has subsequently been adopted by ASTM as F2084 Standard Guide for Collecting Containment Boom

Performance Data in Controlled Environments (ASTM, 2012). The booms involved in the tests were:

- American Marine
- Dome
- Pyroboom
- Spill-Tain
- Oil Stop Inflatable

First loss tow speeds were in the range of 0.85 to 1.0-knots in calm water for each of the five booms. First loss tow speed was largely unaffected by regular waves, with some reduction measured in short-crested waves. The authors suggested that results indicated that increased buoyancy-to-weight ratio would be beneficial for oil collection performance, but the tests did show that the generally low B:W ratios of these fire-resistant booms, generally in the range of 2.0 to 3.5, were adequate for good performance.

Tests were performed at the U.S. Coast Guard Fire and Safety Test Detachment in Mobile, AL to evaluate the use of propane for testing fire-resistant boom (Walton *et al.*, 1997). Propane has an advantage over pooled liquid hydrocarbons in that it produces a relatively smoke-free burn which simplifies permitting for testing. Heat fluxes measured at the boom location from a propane fire were approximately 60% of that from a liquid fuel fire.

Mid-scale and full-scale tank testing was performed on the same fire-resistant boom as was used in the NOBE trials to measure the effects of waves and current in conjunction with the heat flux of a burn (McCourt *et al.*, 1997). Alternating 1-hour periods of heat exposure followed by waves were used to simulate the collection and burning phases of an in situ burn. Observed degradation was similar to that measured in the NOBE experiment, but was found to occur at a slower rate. This was concluded to be due to the lower heat flux produced by the propane burn that was used to provide heat exposure for the tests.

Based on the limits of these tests, an enhanced propane system was developed, comprising an increased flowrate of propane through the delivery system and the addition of compressed air to intensify the combustion (McCourt *et al.*, 1999). As in the earlier tests, an unused section of boom from the NOBE trials was used and exposed to alternating one-hour periods of flames and waves. The temperatures and measured heat flux were comparable to that of a crude oil fire, and the observed degradation of the boom was similar to that in the NOBE experiment. It was concluded that the test would provide a reasonable analog for screening fire-resistant booms.

Further development of a standardized test protocol was carried out in a purpose-built wave tank, with diesel used as fuel for the in situ burn (Walton *et al.*, 1998, 1999). A 15-metre section of boom was positioned in a circle within the tank, and subjected to alternating one-hour periods of waves and burning oil. Five different booms were tested; however, as the objective of the tests was to evaluate the test protocol, the booms are identified only generically. The test protocol was judged to be the most realistic simulation to date of the thermal and mechanical stresses presented to a fire-resistant boom, albeit with the production of smoke. The protocol was developed in conjunction with the ASTM subcommittee on in situ burning, and led to the development of a standardized test method, *F2152-07 STANDARD GUIDE FOR IN SITU BURNING OF SPILLED OIL: FIRE-RESISTANT BOOM* (ASTM, 2012).

The Dome stainless steel boom was originally designed and built in the 1980's with somewhat rigorous design criteria related to its intended use in the Arctic and, as a result, was heavy, expensive, and difficult to deploy. The boom was re-engineered in the late 1990's to reduce its size, weight, cost, and handling problems (Buist *et al.*, 1999). A prototype was built and subjected to the ASTM burn test protocol (then under development) using both diesel-fueled fires and the OHMSETT enhanced propane system. The boom was also subjected to standard oil containment testing at Ohmsett, and components were tested in the lab to confirm their long-term performance. It was suggested that the boom could be used as a stand-alone fire-containment system, or used as a high-strength durable burn pocket inserted between two lengths of conventional fabric fire boom.

Allen (1999) provides a good summary of advances in boom technology, including a comparison of refractory fabric booms, stainless steel booms, and actively-water cooled booms. The report also describes the use of fire boom in "protective" rather than spill response mode, and describes an exercise with a team of fire fighters to deploy fire-resistant boom to protect a vessel-handling facility.

In 1999 and 2000, the U.S. Coast Guard conducted three on-water exercises to develop and practise procedures for in situ burning operations (Bitting *et al.*, 2001). Elastec water-cooled fire boom was used in the exercises and oranges were released into the water as a simulant for oil to provide a target for operations. Several modes of operation were examined including direct containment of the "oil" for burning, as well as the use of conventional boom to collect and concentrate oil prior to it being funneled into the fire boom for burning. The results were used to refine operational procedures for the use of in situ burning as a viable response tool.

In the late 1990s and early 2000s a series of fire boom tests were carried out at OHMSETT using the propane fire test system installed at OHMSETT (<http://www.ohmsett.com/>) and using the fledgling (at the time) ASTM test protocol. The reports on these tests may be found on the BSEE web site at <http://www.bsee.gov/Research-and-Training/Technology-Assessment-and-Research/tarprojectcategories/In-Situ-Burn-Research.aspx>. Table 6-2 summarizes the results of these tests (SL Ross, 2002).

Table 6-2: Summary of Fire Boom System/Component Propane Flame Tests at Ohmsett								
Name	Type	Test Results					Thick Oil Test	Comments
		Pre-Burn Stress	1 st hr	2 nd hr	3 rd hr	Post-Burn Stress		
ACS SWEPI ¹	Refractory	Pass	Pass	Pass	Pass	Pass	56-mm	Waves overwashed boom during burns; 56-mm oil filled boom to bottom
AFTI Pocket Boom ²	Steel	Not Done	Pass	Pass	Pass	Not Done	Not Done	Some minor cracks in top of connectors after third burn
AFTI Reflective Blanket #1 ³	Al-Zetex w felt	Not Done	Second best-12 feet from fire			Not Done	Not Done	Prevented boom from heating to > 280°F for 10 minutes

Table 6-2: Summary of Fire Boom System/Component Propane Flame Tests at Ohmsett

Name	Type	Test Results						Comments
		Not Done	Third best-16 feet from fire	Not Done	Not Done	Not Done	Not Done	
AFTI Reflective Blanket #2 ³	SS mesh	Not Done	Third best-16 feet from fire	Not Done	Not Done	Not Done	Not Done	Boom temp exceeded 280°F, some discoloration of blanket surface
AFTI Reflective Blanket #3 ³	Al-Zetex	Not Done	Best-10 feet from fire	Not Done	Not Done	Not Done	Not Done	Prevented boom from heating to > 280°F for 10 minutes
E/AM Fire Boom ⁴	Refractory	Pass	Pass	Marginal	Fail	N/A	Failed after 4 hr	Tests conducted in Ottawa, holes in fabric after 2 hr, significant abrasion after 3
E/AM Hydro Fire Boom ⁵	Water cooled	Not Done	Pass	Pass	Pass	Not Done	Not Done	Fire tests only. Difficulty keeping boom from rolling over when wet
E/AM Blanket ³	Water cooled	Not Done	Pass	Pass	Fail @ 46 min	Not Done	Not Done	Failed at connector. Underlying boom section holed and deflated
EMTA Blanket ⁵	Water cooled	Not Done	Fail @ 8 min	-	-	Not Done	Not Done	Hot spot burned through to underlying boom
Oil Stop Blanket ^{3,5}	Water cooled	Not Done	Pass	Pass	Pass	Not Done	Not Done	Passed both test series (1998 and 2000). Boom rolled over when wet.
Oil Stop Auto Boom Fire Model ¹	Refractory	Pass	Pass	Fail @ 24 min	-	Not Done	Not Done	Some cracking after pre-burn test, more cracks after first burn, sank during

¹ Buist et al. 2001a
² SL Ross 1999
³ SL Ross 2000
⁴ McCourt et al 1998
⁵ Stahovec et al. 1999

As part of a multi-year lab and field experiment to examine oil spill behaviour in ice and various countermeasures for such spills, tests were performed with fire-resistant boom in a range of drift ice concentrations (Potter & Buist, 2010). In the test programme in 2008, tests were performed without oil, and confirmed the ability of two commercially-available fire booms to contain ice while under tow such that a “contain-and-burn” operation could be performed in light ice conditions. Two booms were tested: the Elastec/American Marine Boom (formerly known as the 3M Boom), and the AFTI PyroBoom: each boom was able to contain ice at speeds in excess of the normal containment limits of oil, i.e., 0.35 to 0.5 m/s. Tow loads were measured and found to be on the order of double the loads experienced in open water.

In 2009, the booms were tested in two different ice conditions, a field of 3 to 5/10ths ice, and in trace ice conditions. In these tests, each boom was deployed and then manoeuvred to capture ice floes to fill the boom’s apex. Some 4-m³ was released into the contained ice and then ignited. In each test, a high percentage of the oil was removed through in situ burning, some 98% in the first test and 89% in the second. The burn in the second test was less effective and

took much longer due to the presence of more densely packed brash and frazil ice and due to the presence of waves. The tests demonstrated the ability to use fire-resistant booms in light drift ice to collect oil and ice for in situ burning. This technique should have excellent applicability for spills in trace to 3/10ths ice concentration.

In situ burning using fire-resistant booms was used extensively during the response to the DWH blowout in 2010 (Allen *et al.*, 2011; Mabile, 2010 and 2012), and is described in the next Chapter of this report.

6.3.2 Presently Available Fire Resistant Booms

The fire-resistant booms that are presently available on the market are documented below. The suppliers of commercially available boom were identified through a survey of companies identified in the World Catalog of Oil Spill Response Products (Potter, 2008) and internet searches. The available booms are divided into two categories: those constructed of stainless steel and those constructed from fire-resistant fabrics.

Before presenting the information on available fire-resistant booms it is worthwhile to review materials-of-opportunity that have been used to construct booms to contain oil for in situ burning. The most common material has been logs (McLeod & McLeod, 1972; McAllister & Buist, 1981; Robertson, 1991). Generally, the logs have been either available as an already constructed boom from logging operations or chained together using logging equipment and techniques. Although very effective as a fire-resistant barrier (only the above-water portion of the log chars) they are restricted for use in calm waters. Several instances of using finished lumber to construct small fire resistant booms for calm waters have also been reported (Dome, 1981b; Smith & Diaz, 1985; Burns, 1988; and SINTEF & SL Ross, 1993) including one instance where nine-tonnes of oil were burned offshore during tests of the Kontax igniter (Battelle, 1979).

The other material that has been extensively used as a fire-resistant containment barrier is ice. Ice edges have proven to be excellent barriers against which to burn oil accumulations (Ramsier *et al.*, 1973; Beckett, 1979; Schrier & Ediam, 1979; Dome, 1981b; Industry Task Group, 1983; Smith & Diaz, 1985; SL Ross & Dickins, 1987; Burns, 1988).

The following sections present data on currently available booms constructed of either stainless steel or fire-resistant fabrics. Where possible a summary sheet of boom characteristics is provided; this sheet is adapted, with permission, from the World Catalog of Oil Spill Response Products (Potter, 2008).

6.3.2.1 Stainless Steel Booms

One steel boom is commercially available, the Desmi-AFTI Pocket Boom.

6.3.2.1.1 POCKET BOOM:

Pocket boom is a product developed by:

Desmi-AFTI, Inc. (formerly Applied Fabric Technologies, Inc.)
P.O. Box 575
Orchard Park, NY 14124
USA
phone: 716-662-0632
fax: 716-662-0636

The development of the Pocket Boom was described briefly earlier in this report. It was the result of a research project funded by the U.S. Minerals Management Service (now BSEE) with other JIP partners and involved a re-engineering of the Dome boom (Buist *et al.*, 2001b). **Table 6-3** summarizes the results of these tests (SL Ross, 2002).

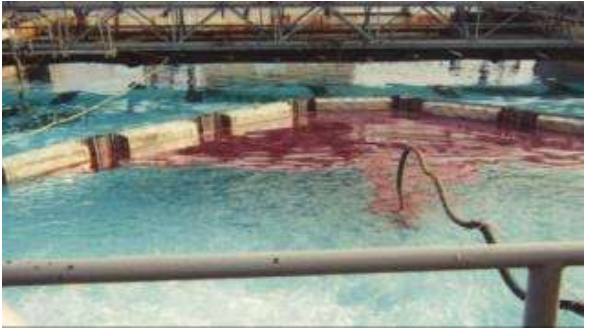
Table 6-3: Desmi-AFTI Pocket Boom	
Desmi-AFTI, Inc. P.O. Box 575 Orchard Park, NY 14124 Tel: 716-662-0632 Fax: 716-662-0636 Contact: Peter Lane	
BOOM TYPE	Fire-resistant
MODEL	Pocket Boom
FREEBOARD mm (in)	Float section: 350 (14); Connector section: 310 (12)
DRAFT mm (in)	Float section: 650 (26); Connector section: 600 (24)
BOOM HEIGHT mm (in)	Float section: 1000 (39); Connector section: 910 (36)
STANDARD LENGTH m (ft)	
END CONNECTORS	U.S. Navy
SKIRT MATERIAL	Stainless steel
SAIL MATERIAL	Stainless steel
FLOTATION	SS
FLO. MEMBER LENGTH m (ft)	1.67 (5)
WEIGHT kg/m (lb/ft)	Float section: 50-kg (110 lb) total; Connector section: 49-kg (108 lb) total
BUOYANCY/WEIGHT	3:1
WATERLINE BEAM mm (in)	
VERTICAL CG mm (in)	
BALLAST MATERIAL	
BALLAST WEIGHT kg/m (lb/ft)	
TENSION MEMBER (1)/ STRENGTH(1) N (lb)	
TENSION MEMBER (2)/ STRENGTH(2) N (lb)	
TENSION MEMBER (3)/ STRENGTH(3) N (lb)	
TOTAL STRENGTH N (lbs)	180,000 (40,000)
FABRIC TENSILE STRENGTH N/50mm (lbs/in)	
FABRIC TEAR STRENGTH N (lb)	
STORAGE VOL m ³ /m (ft ³ /ft)	
OPERATION	
-OPERATING ENVIRONMENT	0
-SEA STATE	
-TOW SPEED (knots)	1
-PERSONNEL REQUIRED	
-DEPLOYMENT	
-RECOVERY AND STORAGE	
S = sphere; A + attached to skirt; SS = stainless steel; F = foam	

6.3.2.2 Fire Resistant Fabric Booms

The following three booms constructed with fire-resistant fabrics are commercially available.

6.3.2.2.1 American Fire Boom MKII²:

American Fire Boom MIII is produced and marketed by:

Elastec American Marine, Inc.
1309 West Main
Carmi, IL 62821
USA
Tel +1 (618) 382-2525
Fax +1 (618) 384-2740

The product (Table 6-4) consists of high temperature resistant flotation sections constructed of a 3M-patented ceramic foam. This material is stable at temperatures up to 1100^oC. The float core sections are held together with stainless steel knitted wire mesh. These 1.8-m long flotation sections are laid end to end and surrounded by a continuous blanket of 3M NEXTEL fibres. These non-flammable, poly-crystalline, metal oxide fibres are designed for applications at temperatures up to 1370^oC. The NEXTEL layer is wrapped with another layer of stainless steel mesh. This entire package is covered with a sacrificial layer of PVC which extends below the flotation to form a skirt and double-layered pocket for a galvanized, proof coil chain tension member. Short stainless steel seaming bars riveted through the layers underneath the flotation are used to hold the package together. Individual flotation sections are contained in 2.1-m long segments separated by a metal clamp fastened through the PVC/mesh/NEXTEL "sandwich". The connector for each 15.2-m section (consisting of seven segments) is a stainless steel plate quick connector.

This product has evolved since the mid-1980s as a result of improvements made after extensive testing. Initial testing of a 3M fire-resistant blanket designed to be attached over conventional boom was conducted in 1985 (Allen, 1986); the blanket, which depended on wicking action, did protect the underlying conventional boom to some extent but had problems. Next was a series of tests in 1987 with an early prototype of the boom. First, an 8.5-m long section of 10" prototype survived 6-hours exposure to burning heptane (maximum recorded temperature of 815^oC) with no sign of thermal stress and little loss of material strengths (Allen & Fischer, 1988). Next, a 7.3-m long prototype section was exposed to crude oil flames for 24-hours. Maximum flame temperatures exceeded 1000^oC. After 24-hours the boom succeeded in containing burning oil in a quiescent tank and appeared to have suffered little or no damage.

The next series of tests involved a calm water burn on seawater in a fjord at Spitsbergen, Svalbard, Norway in 1988. The boom was held in a "U"-configuration by two boats and 1900-L of Statfjord crude was burned off (Allen, 1990a).

² Originally developed by 3M and known as 3M Fire Boom, it was licensed to American Marine, Inc. in 1994.

Table 6-4: American MKII Fire Boom	
<p>Elastec American Marine, Inc. 1309 West Main Carmi, IL 62821 USA Tel: (618) 382-2525 Fax: (618) 382-2740</p>	
	Curtain, fire-resistant
MODEL	12" flotation by 18" skirt
FREEBOARD mm (in)	229 (9)
DRAFT mm (in)	533 (21)
BOOM HEIGHT mm (in)	762 (30)
STANDARD LENGTH m (ft)	15 (50)
END CONNECTORS	Quick
SKIRT MATERIAL	Reinforced PVC
SAIL MATERIAL	PVC/steel mesh/Nextel
FLOTATION	CS-I-Ceramic F*
FLO. MEMBER LENGTH m (ft)	1.8 (6)
WEIGHT kg/m (lb/ft)	12 (8.1)
RES. BUOYANCY kg/m (lb/ft)	47.6 (31.9)
RESERVE BUOYANCY IWEIGHr	3.8:1
WATERLINE BEAM mm (in)	263 (10)
VERTICAL CG mm (in)	263 (10)
BALLAST MATERIAL	6-mm (1/4-in) galvanized chain
BALLAST WEIGHT kg/m (lb/ft)	0.8 (0.5)
TENSION MEMBER (1)/STRENGTH (1) N (lb)	Chain 22,500 (5,000)
TENSION MEMBER (2)/STRENGTH (2) N (lb)	Fabric 171,000 (38,000)
TENSION MEMBER (3)/STRENGTH (3) N (lb)	Connector 44,100 (9,900)
TOTAL STRENGTH N (lbs)	
FABRIC TENSILE STRENGTH N/50mm (lbs/in)	
FABRIC TEARSTRENGTH N (lb)	675 (150)
STORAGE VOL m ³ /m (ft ³ /ft)	0.13 (1.40)
OPERATION	
-OPERATING ENVIRONMENT	C-P*
-SEA STATE	1-2
-TOW SPEED (knots)	0.5-0.75 (10)
-PERSONNEL REQUIRED	2
-DEPLOYMENT	Towed from tray
-RECOVERY AND STORAGE	
*COMMENTS: The boom incorporates numerous design improvements as a result of extensive testing (see text for details on testing).	
CS -segmented cylinder; I -internal; F -foam; C -calm; P -protected.	

The next use of the boom was for a test burn during the response to the *Exxon Valdez* spill in March 1989. Some 57 to 114-m³ of North Slope crude oil was burned in the pocket of a 137-m long 3M Fire Boom of a second-generation design. The burn lasted a total of 75 minutes of which 45 involved intense burning. The second-generation boom suffered some damage due

to thermal stress resulting in some loss of freeboard and embrittlement of the fabric between flotation sections (Allen, 1990). Subsequent, in-house, test programmes from July 1990 to May 1991 involved quiescent salt water tank tests with burns as long as 24-hours (Allen, 1992). These tests resulted in design modifications to the 3M Fire Boom. In November 1990, Alaska Clean Seas conducted a 48-hour burn test of a new version of an 8" 3M Fire Boom. Although the boom survived the test, upon removal it was charred and brittle, there was some deterioration of the fire resistant components of the boom between the flotation sections, and the weight of the connectors was causing a loss of freeboard (ACS, 1991). Design changes were to be incorporated to address these issues.

Next, 212-m of the 18" version was used to contain the burning oil at the Newfoundland Offshore Burning Experiment (NOBE) in August 1993. These burns were conducted 45-km offshore of St. John's, Newfoundland in 0.5-m waves with 8 to 11 km/h winds (OSIR, August 19, 1993; NOBE Newsletter, 1993). Two discrete burns were conducted. The first involved 48.3-m³ of slightly weathered crude oil burned over a 1.5-hour period. Initially, some splashover of the oil was observed; however, most of this oil was retained in the stagnation zone aft of the boom and subsequently ignited and burned by the main fire. At the end of the first burn, the boom was inspected. Some signs of fatigue in the stainless steel were observed at a point about 10-cm from the vertical stiffeners and some of the Nextel fabric was missing; however, the boom was considered fit enough for a second burn (NOBE Newsletter, 1993).

One-hour and 15-minutes into the second burn several flotation sections from the boom came loose, oil began to leak and oil addition was stopped. After the fire had stopped (28.9 m³ had burned) the boom was again inspected. A section of the boom that incorporated a middle tension member had lost three flotation sections and a number of other sections were completely missing Nextel fabric near the vertical stiffeners (NOBE Newsletter, 1993; Raloff, 1993). It is presumed that the combined action of heat, saltwater and wave action were to blame for this self-abrasion problem; this has been noted before (e.g., Dome, 1981a; Roberts & Chu, 1978).

As noted previously, the American Fire Boom was tested as part of the SINTEF-led oil-in-ice experiments in Svalbard in 2008/2009 (Potter & Buist, 2010). The boom was towed through an area of loose drift ice, with the concentration varying from 3 to 5/10ths. With the boom in a U-shape and ice filling its apex, crude oil was discharged into the boom. Initially only 200-L was discharged to confirm that the oil would flow into the boomed area and be contained. In fact, approximately 50-L escaped containment, so the 100-m long towlines were brought in half way to reduce the likelihood of oil losses. The balance of the 4-m³ was discharged without loss. After the towlines were let out to their full length, a small rescue boat moved to a position between the leading ends of the boom and placed several igniters in the water upstream of the contained oil and ice. The igniters were gelled gasoline contained in zipper-locked plastic bags. The igniters drifted back into the oil, and the oil was soon completely afire. The ensuing burn lasted approximately 25-minutes. After the main fire, a small area was re-ignited and burned for an additional 13-minutes. Following the burn, the boom was visually inspected and found to have no significant damage. The estimated burn effectiveness was 98%.

Deepwater Horizon

American Fire boom was extensively used in response to the DWH spill, with a total of 37 systems used to perform 187 burns (Mabile, 2010). There is little documentation on the longevity of the fire booms used in the response, but this equates to an average of 5.1 burns

per system. The longest recorded burn with this boom was 11-hours, 21-minutes. It was thought that the build-up of residue on the boom fabric would, over time, enhance the oil-holding properties of the boom.

6.3.2.2.2 Hydro-Fire MKII System:

is produced and marketed by:

Elastec American Marine, Inc.
1309 West Main
Carmi, IL 62821
USA
Tel +1 (618) 382-2525
Fax +1 (618) 384-2740

The Hydro-Fire boom ([Table 6-5](#)) is an actively-cooled fire-boom, comprising an inflatable boom that is covered with fire-resistant material that is continuously soaked with water supplied by pumping. The boom is packaged as a system, with five sections of 30-m (100-ft) lengths stored on a reel; tow lines water pumps, hoses, and hydraulic power unit. In operation, the pumps are stationed on the towing vessels and supply a continuous flow of water to the boom. A series of hoses within the protective layer on the boom's freeboard ensure a positive and uniform flow of water to the areas of the boom subject to heat exposure.

The boom has been tested in a number of venues including OHMSETT, using the enhanced propane system, and at the U.S. Coast Guard burn facility in Mobile, AL where it passed the ASTM burn protocol when subjected to a diesel-fueled burn.

Deepwater Horizon

Hydro-Fire boom was extensively used in response to the DWH spill, with a total of 27 systems used to perform 138 burns (Mabile, 2010). There is little documentation on the longevity of the fire booms used in the response, but this equates to an average of 5.1 burns per system. The longest recorded burn with this boom was 11-hours, 48-minutes. It was thought that the buoyancy of the Hydro-Fire boom, which at 6.3:1 is relatively high for a fire-resistant boom, provided for better sea-keeping and oil retention in other than calm conditions.

Table 6-5: Elastec American Marine Hydro-Fire Boom

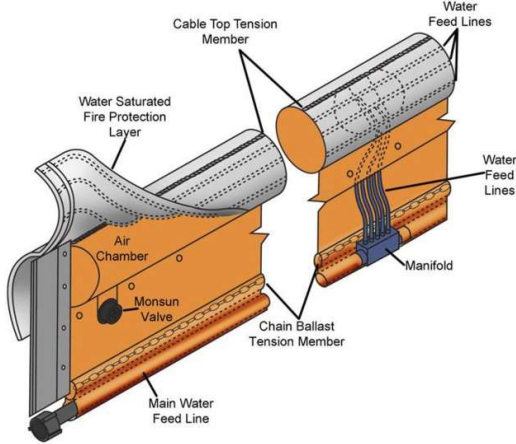
<p>Elastec American Marine, Inc. 1309 West Main Carmi, IL 62821 Tel: (618) 382-2525 Fax: (618) 382-2740</p>	
	Curtain, pressure inflatable, fire-resistant
MODEL	HYDRO-FIRE Boom 14" X 18" System
FREEBOARD mm (in)	360 (14)
DRAFT mm (in)	(460 (18)
BOOM HEIGHT mm (in)	810 (32)
STANDARD LENGTH m (ft.)	500, five 100 ft. sections (150, five 30-m sections)
END CONNECTORS	Universal Slide
SKIRT MATERIAL	
SAIL MATERIAL	
FLOTATION	CS-I-I
FLO. MEMBER LENGTH m (ft.)	1.8 (6)
WEIGHT kg/m (lb/ft.)	12 (8.1)
RESERVE BUOYANCY/WEIGHT	6:1
WATERLINE BEAM mm (in)	300 (12)
VERTICAL CG mm (in)	
BALLAST MATERIAL	9-mm (3/8-in) galvanized chain
BALLAST WEIGHT kg/m (lb/ft.)	2.3 (1.5)
TENSION MEMBER (1)/ STRENGTH (1) N (lb)	1/4 S.S. Cable (6mm); 28,500 (6,400)
TENSION MEMBER (2)/ STRENGTH (2) N (lb)	Fabric 105,000 (23,600)
TENSION MEMBER (3)/ STRENGTH (3) N (lb)	
TOTAL STRENGTH N (lbs)	156,000 (35,000)
FABRIC TENSILE STRENGTH N/50mm (lbs/in)	
FABRIC TEARSTRENGTH N (lb)	
STORAGE VOL m ³ /m (ft ³ /ft.)	On a reel
OPERATION -OPERATING ENVIRONMENT -SEA STATE -TOW SPEED (knots) -PERSONNEL REQUIRED -DEPLOYMENT -RECOVERY AND STORAGE	O 1 4 Inflated from reel
<p>COMMENTS: HYDRO-FIRE boom is water-cooled, the boom's cover remains at ambient water temperature. Water is supplied by two diesel-powered, self-priming water pumps that deliver water to the boom through a 1000-ft of hose that is supported in the water with floats. The water saturates the boom to provide cooling during a burn.</p> <p>CS -segmented cylinder; I -internal; I – Inflatable; F -foam; C -calm; P -protected.</p>	

PYROBOOM:

is a product developed and marketed by:

Desmi-AFTI, Inc. (formerly Applied Fabric Technologies, Inc.)
P.O. Box 575
Orchard Park, NY 14124
USA
Tel: 716-662-0632
Fax: 716-662-0636

This fence type boom (**Table 6-6**) consists of a sail constructed of Fibrefrax fabric supported by Inconel wire mesh and coated with silicone rubber bonded to a PVC coated fabric skirt. Chain in a pocket at the bottom of the boom provides ballast and tension resistance (this replaces the lead ballast on earlier versions). Flotation is provided by a series of stainless steel hemispheres bolted together above and below the waterline. The floats are filled with a high temperature-resistant, closed cell foamed glass.

The boom was tested twice, in 1985 (Allen, 1986); these tests involved both fire tests in quiescent conditions and towing and containment tests in a wave tank. The fire tests involved 7.6-m of Pyroboom containing burning Cook Inlet crude for a period of 24-hours. Peak recorded flame temperatures were 930°C. Within a few minutes of starting the burn the silicone coating on the upper part of the boom's sail began to discolour and small sections of the underlying wire were exposed. Shortly thereafter it was possible to see the flames through pinholes in the upper 5-cm of the sail. The discoloration continued to move down the sail as the first-hour of testing progressed. After one-hour an inspection of the boom revealed that the fire resistant fabric was still flexible and strong. The steel hemisphere and connector showed no signs of thermal stress. After 6-hours exposure the boom was still containing oil and remained flexible. The upper 5 to 10-cm of the sail continued to degrade with several small holes where the internal Inconel wires were exposed. About 5 to 7-cm above the waterline a few small 1 to 1.5-mm diameter holes had appeared; however, these were plugged by baked-on burn residue. During the remainder of the 24-hour test the boom continued to contain the burning oil without loss of freeboard (Allen, 1986).

On completion of the test, the boom was removed and examined. In the area 10 to 13-cm above the waterline there were numerous holes in the fire resistant fabric ranging in size from pinholes to 1 to 2-mm. Near the top of the sail a few holes on the order of 6 to 7-cm² could be found. The baked silicone rubber and fabric in the upper area of the boom was very susceptible to abrasion. From the waterline to a height of 10 to 13-cm the combination of silicone and burned oil residues had created a flexible and impermeable barrier protecting the boom. Although there were indications of some melting of the foam inside the floats, it was minimal and did not result in any loss of freeboard during the tests.

Subsequent towing tests in Houston (Allen, 1986) resulted in significant oil simulant losses at tow speeds above 0.35 m/s; the manufacturer states that this was likely due to an overly stiff skirt fabric employed in the model tested. The design has been modified to include a more flexible skirt which is reported to have performed well during tests at OHMSETT with non-fire

Table 6-6: Desmi-AFTI Pyroboom	
<p>Desmi-AFTI, Inc. P.O. Box 575 Orchard Park, NY 14124 phone: 716-662-0632 fax: 716-662-0636 Contact: Peter Lane</p>	
BOOM TYPE	Fence
MODEL	Pyroboom
FREEBOARD mm (in)	300 (11)
DRAFT mm (in)	480 (19)
BOOM HEIGHT mm (in)	760 (30)
STANDARD LENGTH m (ft.)	15 (50)
END CONNECTORS	
SKIRT MATERIAL	PVC coated fabric
SAIL MATERIAL	Silicone coated Fibrefrax interwoven with stainless steel
FLOTATION	S-A-SS/F*
FLO. MEMBER LENGTH m (ft.)	
WEIGHT kg/m (lb/ft.)	13 (9)
BUOYANCY/WEIGHT	3.3:1
WATERLINE BEAM mm (in)	
VERTICAL CG mm (in)	
BALLAST MATERIAL	9.5-mm (3/8-in.) galv. chain
BALLAST WEIGHT kg/m (lb/ft)	
TENSION MEMBER (1)/ STRENGTH(1) N (lb)	
TENSION MEMBER (2)/ STRENGTH(2) N (lb)	
TENSION MEMBER (3)/ STRENGTH(3) N (lb)	
TOTAL STRENGTH N (lbs)	> 133,000 (> 30,000)
FABRIC TENSILE STRENGTH N/50mm (lbs/in)	9000 (1000)
FABRIC TEAR STRENGTH N (lb)	
STORAGE VOL m ³ /m (ft. ³ /ft.)	0.08 (0.9)
OPERATION	
-OPERATING ENVIRONMENT	
-SEA STATE	
-TOW SPEED (knots)	
-PERSONNEL REQUIRED	
-DEPLOYMENT	
-RECOVERY AND STORAGE	
<p>* S = sphere; A = attached to skirt; SS = stainless steel; F = foam</p>	

resistant boom models of similar design. The Pyroboom boom also experienced some oil-simulant loss in waves of 0.6-m x 12-m during the 1985 tests.

As noted previously, the Pyroboom was tested as part of the SINTEF-led oil-in-ice experiments in Svalbard in 2008/2009 (Potter & Buist, 2010). The test was intended for a low-density area of ice near the edge of the pack. A total of 150 metres of boom was used, consisting of 60-m of Pryoboom, and 90-m of Applied Fabrics GlobeBoom, a conventional containment boom. The two 45-m sections of conventional boom were used as the leading ends of the deployment to save on weight and cost. The fire-resistant boom formed the apex of the U-shape, where the fire would be located. Following deployment, the boom was positioned in a U-shape and towed approximately 1-km in a downwind direction to the intended starting position, collecting ice pieces along the way. The boom was then towed back to the intended starting position, but by this time, the ice had opened significantly and there was little ice to be encountered during the tow, as had been intended. A course was set into the wind, essentially through open water. With the towlines shortened to lessen the drift of oil, 4-m³ of oil was discharged into the contained area. Several igniters were placed upwind of the oil and allowed to drift back to the slick. The ice pieces in this test were small, akin to brash ice, and therefore packed together more densely. As well, there was more slush ice in the mix. As a result, the burn area was not particularly large and the burn took a total of 2-½ hours. Throughout the burn, the boom was subjected to wind waves and swell. Slowing the tow speed and allowing the ice to spread out somewhat could have accelerated the fire, however each time this was attempted, the boom began to swing away from the direction of the tow, presumably due to the effect of currents. This caused the burn area to approach the portions of the boom that were not fire-resistant, and rather than risk losing control of the fire, it was decided to proceed as originally intended, at a speed through water of approximately 0.3-knots. Following the burn, the boom was visually inspected and found to have no significant damage. The estimated burn effectiveness was 89%.

Deepwater Horizon

PyroBoom boom was extensively used in response to the DWH spill, with a total of 13 systems used to perform 58 burns (Mabile, 2010). There is little documentation on the longevity of the fire booms used in the response, but this equates to an average of 4.5 burns per system. The longest recorded burn with this boom was 3-hours, 13-minutes. The original booms provided during this response arrived with aluminum connectors, which degraded somewhat in use, however, post-DWH orders are being made with stainless steel connectors.

6.3.3 Summary of Disused Fire Resistant Booms

The following booms were at one time used or researched and developed but either are no longer commercially available or have been superseded by more recent technology.

6.3.3.1 Air Bubble Barriers

Several investigators have proposed the use of submerged, perforated air pipes or hoses to create a current to retain burning oil (Purves, 1978; Comfort *et al.*, 1979; Williams & Cooke, 1985). There are three key drawbacks to this seemingly attractive approach: the severe logistics associated with providing high flowrates of compressed air at remote locations; the difficulties in correctly ballasting and maintaining level on a long length of submerged hose offshore in waves and currents; and the low failure velocity (as low as 0.2 m/s) of bubble barriers in currents. Williams & Cooke (1985) overcame the first limitation by investigating the use of a porous,

canvas hose submerged just below (at most 1 m) the water surface; this allowed the air flow to be provided by a centrifugal blower, rather than a high pressure compressor. In calm water tests, a 23-m length of 10-cm diameter bubble barrier was used to encircle and contain burning diesel fuel. The authors concluded that the device was viable for quiescent water conditions but required testing in waves, and currents. No such tests have been reported in the literature.

6.3.3.2 Water Spray Barriers

Several designs for fire proofing oil containment barriers with water sprays have been proposed. Alba International (Aberdeen, Scotland) developed a prototype boom incorporating a built-in water tube jetting system for cooling and herding the burning slick. The system was tested at a firefighting school. The system has not been commercially developed because there is not sufficient interest to justify its high cost of manufacturing.

Another water spray system (Purves, 1978) involved attaching small spray nozzles to the sail of conventional boom to keep the burning oil away from the boom and to shield it from radiant heat. This concept was considered but rejected due to the difficulties in correctly aiming water spray nozzles in waves and the likely failure of the entire containment system if only one of many nozzles failed to keep the oil away. Other designs (Comfort *et al.*, 1979; Comfort, 1989) have considered floating spray barrier systems. Tests have shown that a small spray barrier will retain burning oil in quiescent conditions with or without waves (Tam & Purves, 1980); however, further tests have shown that the use of larger, higher pressure systems designed to contain oil in currents tends to reduce the intensity and efficiency of the burn and quickly emulsify the oil (Comfort, 1989). Another key problem, as with air bubble barriers, is that water spray or water jet barriers have severe logistical and operational requirements compared with other fire-containment systems.

6.3.3.3 The GEMENG Concrete Boom

As part of a programme undertaken in the early 1980s to develop cheaper and lighter alternatives to stainless steel booms, Environment Canada funded the development of the GEMENG concrete boom. The basic design was that of a bottom-tensioned, fabric-skirted boom with rigid, hexagonal shaped flotation units. These were strung together on a central, wire-rope towing cable. The final design of the flotation units consisted of a Foamglass core with a castable refractory cement cover. The ends of each float strung on the tow cable were either a ball or socket to permit an oil-tight seal (Meikle, 1983). The units were tested at OHMSETT (Borst 1983) and in protected waters (Solsberg & Belore, 1982). The boom proved capable of containing burning oil at tow speeds up to 0.4 m/s with only minimal oil leakage; the oil that did leak burned in the stagnation zone aft of the towed boom section. No burn tests in waves were reported (Borst, 1983). Some spalling of the concrete cover was reported. During a 72-hour field durability test in 30 to 60-cm waves with a 1.5-second period, the boom prototype suffered considerable damage. This resulted from self-induced abrasion of the ball and socket joint arrangement and banging of adjacent flotation units (Solsberg & Belore, 1982). This boom is not commercially available.

6.3.3.4 The "Quickie" Fireproof Boom

In 1979, Dome Petroleum Ltd., in support of its Arctic offshore drilling operations, funded the construction and testing of a fire resistant boom made with empty 205-L oil drums connected with fire-resistant cloth material. The boom was tested in a quiescent pond at Vancouver airport and proved capable of containing burning oil; long-term exposure (about 1-hour) to the

high temperatures generated by in situ burning caused rapid oxidation of the mild steel drums (McAllister, 1979). This boom was superseded by the Dome stainless steel boom (see next section).

6.3.3.5 *Rope Net Boom*

In the late 1970s, as a result of offshore exploration for oil in the Arctic, a study was undertaken of the feasibility of burning off oil released from a subsea blowout (Arctec, 1977). One concept attempted was that of a slightly buoyant cargo net floating on the water surface that would collect and thicken oil flowing past. The low freeboard of the net combined with water wicking into the net was supposed to maintain the integrity of the boom during an oil fire. Small-scale tests revealed that the boom did not contain oil at thicknesses sufficient to maintain combustion (Ewing, 1979).

6.3.3.6 *Asbestos/Ethafoam Fireproof Boom*

In 1977 Environment Canada funded the construction of a fire resistant boom consisting of 18-cm diameter Ethafoam logs surrounded by a blanket of ceramic wool and covered with an aluminized asbestos fabric used for fire suits (Roberts 1978). The boom was tested with burns of gasoline; the heat melted the aluminum, burned the organic binder out of the asbestos and the Ethafoam flotation was melted in several places (Ewing, 1979; Roberts, 1978).

6.3.3.7 *Reynolds Aluminum*

A now defunct subsidiary of Reynolds Aluminum called Reynolds Submarine Service Corp., manufactured containment boom in heights of 38 and 71-cm (Solsberg, 1983). These were constructed from 3003H14 corrugated aluminum. These had been considered as potential fire resistant booms, but never tested (Purves & Daoust, 1978).

6.3.3.8 *Firefence*

Aqua Guard of Vancouver, BC once manufactured a lightweight fire resistant boom fabricated from galvanized sheet steel. Known as the Firefence, the 4.5 kg/m boom was produced in 2.7-m sections which incorporated piano hinged flexing panels and was joined together with thumbscrews. The boom was evaluated at OHMSETT (Solsberg, 1983). The boom is no longer marketed.

6.3.3.9 *SWEPI Boom*

Beginning in the early 1980s Shell Western Exploration and Production Inc. (SWEPI) began the development of a fire-resistant boom to support its offshore drilling operations in Alaska (Industry Task Group, 1983; SL Ross, 1983; Allen, 1986). The boom, in its final form, was a bottom-tensioned, cylindrical flotation type with multiple layers of a fire-resistant fabric surrounding 20-L steel cans. The boom was encased in a sacrificial plastic sheet that was wrapped in chain link fencing material to provide abrasion resistance (Allen, 1986). A 43-cm deep skirt was attached to the flotation. Five-mm wire cable in the flotation section acted as a tension member; additional tension capability and ballast was provided by a 7-mm chain sewn into the bottom of the skirt.

A unique feature of this boom was the use of the wicking action of the Thermoglas and K.O.Wool fabrics to wick water and cool the boom. The boom was tested several times (Industry Task Group, 1983; SL Ross, 1983; Allen, 1986) for periods up to 24-hours in quiescent conditions and sections were deployed offshore in broken ice conditions (Industry Task Group,

1983; SL Ross, 1983). No further development work was undertaken with this boom after 1986 and it is no longer commercially available.

6.3.3.10 *Fire Guard Boom*

This boom was manufactured and distributed by Gamlen Industries S.A. Saint-Marcel, France but is no longer marketed. The boom was made of short, rigid flotation units connected by flexible fabric panes. The floats are made from two square tubes of AG-3 (presumed to be a grade of galvanized steel or acier galvanise) that is 2-mm thick. These are attached to either side of a 3-mm thick plate of AG3 that serves as sail and skirt. For heat transfer purposes the floats and vertical plate are separated by a 1-cm gap and the connections between the two are insulated with asbestos strips. The design draft and freeboard have been calculated so that there is sufficient heat transfer at 1300°C temperatures to ensure that the boom does not melt. The connectors consist of stainless-steel mesh enclosed in a 3-ply asbestos fabric coated with a sacrificial PVC covering. Stainless steel cables, top and bottom, carry tension loads, rather than the flexible panels. Each unit (float + connector) is 5-m long. Each section is connected by means of five bolts. The unit is claimed to have survived in a hydrocarbon fire for 35-minutes; after exposure to fire the asbestos strips and flexible connections panels must be replaced.

6.3.3.11 *Sandvik Steel Barrier (SSB)*

The SSB was produced and marketed by AB Sandvik Process Systems, Sandviken, Sweden but is no longer marketed. The boom consisted of sheets of cold-rolled stainless steel supported by pontoons of welded stainless steel cylinders. The boom sections are connected by a bolt joint arranged so that the boom can move freely and follow waves. No test data (oil containment or fire resistance) were supplied by the manufacturer. It should be noted that it appears that the pontoons are sealed tightly, which could present air-expansion problems when exposed to high flame temperatures. The manufacturer claims that the product has performed as a containment boom for seven years without maintenance.

6.3.3.12 *Merkalon*

This stainless steel boom was formerly produced by Mannesmann Italiano SPA, Genova, Italy. The boom has an overall height of 70-cm of which 30-cm is freeboard. Each 1.5-m long section weighs 16-kg and is connected via preformed male/female slides. The boom was reported to be able to withstand 800°C (Solsberg, 1983).

6.3.3.13 *Sea Curtain Fireguard*

This boom was manufactured by Kepner Plastic Fabricators, Torrance, California. It is no longer actively marketed but it was used in the recent DWH response (Mabile, 2010) where it did not survive field exposures to in situ burns for an acceptable time span. The boom was designed to be reel-able and self-inflating. As the boom is drawn off the reel, a stainless steel coil springs from a flattened position to a helical position thus providing flotation and freeboard. Additional flexible flotation for the skirt and ballast is attached at the bottom of the inside of the continuous cylindrical flotation section. It consists of high temperature, closed cell foam protected by Thermoglas fabric. The erecting coil supports a double layer of Thermotex coated with a sacrificial abrasion resistant coating; this coating will burn away at 315°C. The skirt is constructed of a heavy-duty polyurethane coated polyester (PVC coated polyester and nylon are also available). Ballast and tensile strength are provided by a galvanized high test chain in a pocket at the bottom of the skirt. The boom has been burn-tested several times in

quiescent, freshwater and saltwater conditions and containment testing was conducted in a wave tank.

6.3.3.14 *Autoboom -Fire Model*

Autoboom is manufactured by Oil Stop Inc., Harvey, Louisiana. It is no longer actively marketed but it was used in the recent DWH response (Mabile, 2010) where it did not survive field exposures to in situ burns for an acceptable time span. The boom is pressure inflated and designed for deployment from a reel or compact storage without a reel. Heat resistance is provided by a refractory covering on the boom fabric as well as tubes that allow water to circulate over the freeboard portion of the boom.

6.3.3.15 *Dome Stainless Steel Boom*

The Dome boom was researched and developed by Dome Petroleum Ltd. over a four-year period from the late 1970s to the early 1980s. The boom, primarily the connector unit (see **Table 5.4**), was redesigned several times as a result of failures in test-tank and field deployment trials. The boom is large (overall height = 1.8 m) and massive in order to meet its design criteria of long-term deployment offshore and resistance to ice impacts. The boom was fire tested for 2-hours in quiescent conditions near Vancouver, BC (McAllister & Buist, 1980), fire and oil containment tested in waves and currents at OHMSETT (Dome, 1981a) and deployed offshore four times for a total of 45-days.

The boom's design consists of two units, the flotation and the connector. The flotation unit consists of a pentagonal cross-section chamber constructed of Type 310 stainless steel with a steel sail and skirt attached. Either end of the flotation unit is fitted with a slotted stainless steel pipe as one part of a double-slide connector. Each flotation unit incorporates a drain plug and wax-plugged vent pipe (for the release of overpressure air during burning and the ingestion of cold air during cooling). The connector units consist of pleated, thin gauge 321 stainless steel sheets through which pass a universally jointed box beam. This design is necessary to avoid the self-abrasion problems associated with mineral-based fire resistant cloth when wetted and the stress cracking problems associated with simpler steel connector designs. Each section (flotation unit plus connector unit) weights 210-kg and is 2.58-m long, has a draft of 1.2-m and a freeboard of 0.57-m. The deployment and retrieval of this boom is a cumbersome process (Dome, 1983).

6.4 Additives

A variety of additives to assist in situ burning have been developed and tested over the years. These can be categorized into three major groups: ignition promoters (also known as primers), combustion promoters (including wicking agents) and smoke suppression additives. Herding agents to thicken oil slicks in drift ice and open water are discussed in the next section.

The *Torrey Canyon* spill in 1967 seems to have spurred the initial development of in situ burning additives. One combination ignition/combustion promoter, Pyraxon, was developed soon after the spill by the Guardian Chemical Corp. and was reported to liquefy heavy, weathered oils and promote burning (Anonymous, 1968).

A multitude of wicking agents (or insulating agents) were also developed at this time, including SeaBeads by Pittsburgh Corning (Anonymous, 1970), Cab-O-Sil by Cabot Corp. (Anonymous, 1968), Ekoperl by Grefco Inc. (Freiberger & Byers, 1971) and Tullanox (Battelle, 1979). These

agents were intended to wick and insulate difficult-to-ignite oils and permit their burning at sea. Sea trials by the EPA and by the U.S. Navy in the spring and summer of 1979 showed that the agents could accomplish these goals, but application was difficult (Freiberger & Byers, 1971; Energetex, 1978). They were used with some limited success on two heavy fuel oil spills in 1970. Testing of these and other natural wicking agents such as straw and peat moss continued throughout the 1970s, with particular application to spills in ice (Energetex, 1979; Tam & Purves, 1980; Coupal, 1972).

In December, 1969, the cargo ship *Eiva* sank releasing 15,000-L of diesel fuel in the Gulf of Finland. Some of this oil was successfully burned on nearby shores and in bays using paraffin oil as an ignition promoter (Haaktela, 1970). Six days later the tanker *Raphael* went aground west of Emäsoalo, Finland releasing more than 60-tonnes of crude. Peat moss (a natural wicking agent), fuel oil and petrol (ignition promoters) were used to remove more than 90% of the oil by burning (Coupal, 1972; Haaktela, 1970).

On February 4, 1970, the *Arrow* ran aground in Chedabucto Bay, Nova Scotia, and spilled most of its 16,250-tonne cargo of Bunker C. SeaBeads were used successfully to burn isolated larger slicks (4.6-m diameter) and oil on some beaches. The slicks were primed with Varsol (Freiberger & Byers, 1971; Battelle, 1979). Part of the spill was burned by first adding two drums of fresh oil as ignition promoter (Coupal, 1972).

In July, 1970, the U.S. Coast Guard conducted a series of small oil-in-ice experiments off Barrow, Alaska using North Slope crude oil. In situ burning of oil on ice and water pools was tested, including five burning agents: peat, straw, silicate beads, asbestos powder, and calcium carbonate (McMinn, 1973).

In January, 1972, 610-tonnes of diesel fuel was accidentally discharged into the icy Ume River in Sweden. The oil spread downriver into a small lake. A particulate sorbent product, "Saneringsull," was used as a wicking agent and about 400-tonnes of oil were burned over a period of a month from a mixture of oil, ice and snow on the lake (Jerbo, 1973).

On December 27, 1976, the *Argo Merchant* went aground near Nantucket Island and spilled most of its cargo of 28,450-tonnes of No.6 fuel oil. Part of the response by the U.S. Coast Guard involved attempts to burn the oil. One 30-m x 40-m x 15-cm thick slick was treated with Tullanox 500 (a wicking/insulating agent), primed with 200-L of JP-4 and ignited with JP-soaked cotton sheets set afire with a flare (Det norske Veritas, 1979; Battelle, 1979).

In the late 1980s, and early 1990s, as a result of increased concern regarding the smoke plume generated by in situ burning, research began into organometallic derivatives that could be used as smoke suppressors (Mitchell, 1990; Mitchell & Janssen, 1991; Mitchell & Moir, 1992; Moir *et al.*, 1993). Ferrocene, and its derivatives, proved capable of virtually eliminating visible smoke emissions in small bench-scale and test tank fires at concentrations of about 2 to 4% by weight (Moir *et al.*, 1993).

Cabioc'h (1993) reports that a system combining an ignition promoter and an igniter was tested in France for burning emulsions.

6.4.1 Ignition Promoters

Ignition promoters are defined as substances added to an oil slick in order to increase its ignitability or to promote spreading of flame over the surface of unignited oil.

6.4.1.1 *Pyraxon*

Pyraxon was a proprietary ignition promoter produced by the Guardian Chemical Corp. of Long Island City, New York, but is no longer commercially available. It was a two-component system consisting of a liquid primer and a powder oxidant-catalyst (Freiberger & Byers, 1971). The liquid primer was intended to act as a pour point depressant, to permit easy ignition and flame spreading, and to provide the heat necessary to initiate the catalytic cracking action of the powder. The powder was supposed to catalyse the conversion of heavy oils into more readily burnable fractions (Freiberger & Byers, 1971). Tests were conducted by the manufacturer in a 36 m² water tank. The crude oil in the tank was initially 1.3 to 5-cm thick; the water temperature was near 0°C. The Pyraxon powder was applied at 5 g/L of crude oil and the liquid was applied at 1:25 (vol/vol). The slick was then ignited and burned. The residue was 0.32-cm thick. Pyraxon was found to be not effective as an ignition promoter for emulsified oil (Energetex, 1979).

The EPA carried out tests of Pyraxon on slicks of Bunker "C" in an outdoor tank. The oil was initially 1.3 to 1.7-cm thick and could not be ignited "as is". Pyraxon liquid and powder were applied to the slick; although the Pyraxon liquid ignited, the Bunker "C" did not (Freiberger & Byers, 1971). It was noted that, while both the liquid and powder were claimed to be stable in storage, care had to be exercised in their storage and handling.

6.4.1.2 *Westcom*

The Westcom products have been presented in the earlier section on igniters. Westcom 2001 (also known as Westcom III) could also be considered as an ignition promoter for emulsified oils. Cabioc'h (1993) states that it offers only a small advantage over gelled diesel fuel.

6.4.1.3 *Volatile Fuel Oils*

Gasoline, diesel, kerosene, aviation gasoline, and even crude oil have often been used as ignition promoters for in situ burning. Middle distillates (diesel, kerosene, etc.) are considered better ignition promoters than lighter petroleum products (gasoline, etc.) for two reasons: first, the lighter products evaporate faster than middle distillates which results in faster cooling of the underlying oil slick (Coupal, 1972; Buist *et al.*, 1983a); and, second, the flame temperature is higher with middle distillates (Bech *et al.*, 1992). It should be noted that with viscous oil slicks it is necessary to spray the fuel oil over an area of the slick; pumping oil onto one point only will result in a localized, thick, pool of fuel. Crude oil, with its wide range of components, is probably the best ignition promoter (Freiberger & Byers, 1971; Energetex, 1980; Bech *et al.*, 1992).

6.4.1.4 *Heli-torch Fuel Additives*

Research has been carried out to improve the capability of the Heli-torch, particularly in igniting emulsified oil. The addition of emulsion breaking surfactants and ferrocene to the fuel used by the Heli-torch shows promise for improving the performance of the device with some emulsions (SINTEF & SL Ross, 1993; Guénette & Sveum, 1995; Thornborough, 1997).

6.4.2 *Combustion Promoters*

Combustion promoters can be defined as substances that are added to a slick to increase the oil removal efficiency by burning. These substances usually act as either a wicking agent or an insulator between the slick and the water substrate, or a combination of the two.

6.4.2.1 SeaBeads

These cellular glass beads were produced by Pittsburgh Corning for use as combustion promoters for heavy oil slicks (Anonymous, 1970). The beads were 6-mm in diameter (3-mm diameter was also available) and made entirely of glass. When applied to an oil slick at the proper dosage they were intended to both wick the oil by capillary action and insulate it for better burning. Tests in small pools by Pittsburgh Corning gave good results with slicks as thin as 0.1-mm; little or no residue was reported from these tests (Anonymous, 1970). Tests were carried out in 1969 with SeaBeads on slicks of Bunker "C" in tanks ranging in thickness from 2.5 to 6.5-mm (Freiberger & Byers, 1971). The dose rate of SeaBeads was 0.32 to 0.41 kg/m². Burning was reportedly complete in areas where SeaBeads had been applied; the slick would not ignite in areas where the product had not been applied. SeaBeads were also tried on small Bunker "C" slicks from the *Arrow* spill in 1970. The product was applied to 4.6-m diameter slicks at a dosage of 0.5 kg/m². The slicks were primed with Varsol and ignited with a marker flare; only 50% of the oil was removed despite several ignition attempts (Freiberger & Byers, 1971).

In May, 1970, tests of SeaBeads on slicks in the North Atlantic Ocean were conducted by the U.S. Navy (Freiberger & Byers, 1971). During these tests a series of uncontained Bunker "C" slicks were created and ignition attempts made. It proved impossible to ignite untreated Bunker "C". Numerous unsuccessful tests of SeaBeads were conducted in a range of sea and weather conditions; the problem was an inability to broadcast the product onto the slick from a vessel. Winds of 25 to 40 km/h and rain prevented seeding of the slicks; even gentle breezes prevented satisfactory application. Two slicks were successfully treated and burned; these were correctly dosed with SeaBeads applied by hand from the side of the vessel. An area approximately 1-m x 10-m was dosed and ignited in one test. The sea temperature was 7°C and the swells were 2.5 to 3-m in height. About 66% of the oil ignited was estimated to have been burned (Energetex, 1979).

Contained slick burning tests were conducted by the EPA off the coast of New Jersey in the summer of 1970. These tests gave rise to the following conclusions:

- Adequate broadcasting techniques did not exist for the SeaBeads; hand spreading was the technique used most effectively.
- Contained crude oil could be burned without the use of a combustion promoter.
- Bunker "C" could not be ignited without a combustion promoter like SeaBeads; with SeaBeads an 80 to 90% reduction by burning was achieved.

In 1971, winter tests of SeaBeads in Alaska were conducted by the U.S. Coast Guard (Glaeser & Vance, 1971). A series of burns of Prudhoe Bay crude on ice and water revealed that the application of combustion promoters did not conclusively reduce the amount of residue remaining after a burn.

SeaBeads were tested again in 1979 by Environment Canada (Tam & Purves, 1980). These small-scale tank tests involved fresh and aged Alberta crude oil in 1.5-m² surface area tanks with various initial slick thicknesses and promoter loadings. SeaBeads produced effective burns, but its effectiveness was sensitive to loading. In areas where the slick was overdosed, the SeaBeads would tend to submerge the slick, get wet and prevent ignition. The optimum dosage for SeaBeads was estimated to be 0.25 to 0.5 kg/m² of slick area.

SeaBeads are no longer considered for use because of the high dosage rates required and the difficulty in properly applying the product to large areas.

6.4.2.2 *Cab-O-Sil, Aerosil, Tullanox*

These three commercial powder products have been grouped together because they all are silicon dioxide treated with a silane coating for hydrophobicity. Cab-O-Sil ST-2-0 was produced by the Cabot Corporation of Boston; Aerosil R972 is produced by Degussa Inc. in Teterboro, NJ; and Tullanox 500 was produced by Tulco, Inc. Cab-O-Sil was the most tested of the three products, having been assessed in four experiments (EPA Laboratory Tests —Freiberger & Byers, 1971; U.S. Navy field tests -Freiberger & Byers, 1971; Arctic tests -Glaeser & Vance, 1971; and Environment Canada tests - Tam & Purves, 1980) and at least one spill, The *Othello* in 1970 (Battelle, 1979). Tullanox was used to aid ignition at two spills (*Arrow* and *Bouchard #65* -Schrier & Eidam, 1979; Battelle, 1979). Aerosil tests were reported by Tam & Purves (1980).

All three products seem able to wick and insulate otherwise unignitable oil and promote its efficient combustion; however, the difficulty in applying these powders at sea, particularly in winds, the high dose rates required (7 to 10% by weight), and their inhalation toxicity make their use difficult in many spill situations.

6.4.2.3 *Fibreperl, Ekoperl, Wonderperl*

These three products produced respectively by Breco Inc. of Los Angeles, CA, Grefco Inc. of New York, NY, and Perlite Popped Products of Santa Fe, CA respectively were all expanded perlite (aluminum silicate) products treated with a surface agent so as to be hydrophobic. Fibreperl was a mixture of expanded perlite and cellulose fibres.

Ekoperl was tested in 1969 by the EPA. About 0.1-kg of Ekoperl was added to 2-L of Bunker "C" in a 2-cm thick slick. The oil was ignited but only 33% burned (Freiberger & Byers, 1971). Tam & Purves (1980) report that tests of Fibreperl resulted in almost complete removal of crude oil slicks by burning and left a dry, buoyant, cohesive residue. They gave the optimum dosage as 0.64 to 1 kg/m².

Because of the difficulties in applying these products and the high dosages required, their use is not recommended on larger spills.

6.4.2.4 *Vermiculite*

Vermiculite is expanded mica and is available locally from garden supply stores. Tam & Purves (1980), who conducted tests with Vermiculite on crude oil, reported that it produced effective burns, but in overloaded areas tended to submerge the oil, get wet and thus prevent ignition in these areas. They gave the optimum dosage as 0.2 kg/m². Vermiculite is not considered a viable combustion promoter for large spills because of its high dosage rates and the probable difficulty of applying the product to spills at sea.

6.4.2.5 *Natural Products as Combustion Promoters*

Straw was tested by the EPA in 1969 as a combustion promoter. Eighty grams of straw were applied to a 2-cm thick Bunker "C" slick containing 2-L of oil. The straw was ignited with a gas torch. The straw appeared to burn down to a web of filamentous carbon which subsequently ignited the oil and sustained its burning through a wicking action. About 80% of the oil was consumed. Glaeser & Vance (1971) also tested straw with Prudhoe Bay crude spills on ice and found no advantage to its use. Tam & Purves (1980) tested straw with crude oil on water and

found that it resulted in a fairly effective burn but the heavy carbonized straw residue was difficult to collect. They recommended an application rate of 20% straw by weight.

Peat moss has been extensively tested as a combustion promoter. Peat moss was used in 1968 at the cleanup of the *Raphael* spill off the coast of Finland. Responders used 300 bales of peat moss soaked with 1,653,500-L (250 bbl) of fuel oil and petrol to burn 90% of the spilled oil trapped in ice. Coupal (1972 and 1976) reported on tests with peat moss soaked with diesel oil as a combustion promoter for Bunker "C" and crude oil fires. With peat loadings of about 7% by weight and diesel loadings of 1% by weight removal efficiencies of 70 to 90% were obtained with test slicks of Bunker "C" ranging in volume from 30 to 400-L. Crude oil removal efficiencies of 80 to 95% were obtained with peat loadings of 3 to 5% by weight and diesel loadings of 1%. Tam & Purves (1980) reported good results with peat moss as a combustion promoter. They recommended loadings of 10% by weight for crude oil burns. Peat burn residue was much easier to recover than straw. Energetex (1981c) assessed burning as a shoreline cleanup technique and showed that the use of peat moss as a combustion promoter improved the efficiency of the approach. A residue remained afterwards that would require removal.

Of all the combustion promoters, only peat moss with diesel fuel is recommended for consideration primarily due to its low cost and ready availability. Due to anticipated problems with application over large areas it should be considered for use on smaller spills where it can be manually applied.

6.4.2.6 Sorbent Products as Wicking Agents

A variety of manufactured sorbents have been used successfully as wicking agents, including Saneringsull (Jerbo, 1972) and polypropylene sorbent sheets and pads (Buist *et al.*, 1983a). Their use is restricted to smaller spills where access is available for manual application of the sorbent.

6.4.2.7 Emulsion Breakers

In the 1990s, the research emphasis for ISB processes focused on the burning of water-in-oil emulsions, since the second attempted burn of ANS crude from the *Exxon Valdez* reportedly failed due to the high emulsion water content of the slick (Allen, 1991a). Programmes of research were carried out in North America (Buist *et al.*, 1997 and 1998; Walavalkar & Kulkarni, 2001), and jointly in Canada and Norway (Bech *et al.*, 1992 and 1993; Guénette *et al.*, 1995; Guénette & Sveum, 1995; Guénette & Wighus, 1996) to investigate the burning of emulsified oil slicks on water and amongst ice in various environmental conditions, including waves. The basic conclusions of this research were that:

- For most crude oils, emulsified water contents in excess of 25% preclude ignition (some very light crudes that do not form stable emulsions can be ignited with water contents up to 60%).
- The burn rate and efficiency for emulsions decline with increasing water content.
- Wave action makes ignition of emulsified slicks more challenging, slows in situ burning rates and increases the thickness of residue that remains when the slick naturally extinguishes.

Research on the use of emulsion-breaking chemicals (a.k.a. demulsifiers) added prior to ignition to enhance burning of emulsions was also carried out (Buist *et al.*, 1997). New formulations of Heli-torch fuel were also pursued in the 1990s to improve the ignition of emulsions and other problematic oils (Guénette & Sveum, 1995). The enhancements included:

- The use of fresh crude oil instead of gasoline to provide a hotter flame;
- The addition of emulsion-breaking chemicals to the igniter fuel to aid in the ignition of emulsions with water contents greater than 25%; and,
- The addition of anti-foaming agents to suppress foaming of burning emulsions that can extinguish a burn.

A successful offshore field test using an emulsion-breaking igniter was carried out in UK waters with evaporated crude containing 25% emulsified water held in a fire boom (Guénette & Thornborough, 1997). A recent study of contained slicks of stable emulsions in a wind/wave tank has indicated that the application of demulsifiers to a thick slick of emulsion, such as in a towed fire boom, would not cause spontaneous emulsion breaking (SL Ross, 2012a). The provision of additional mixing energy (to mix the demulsifier into the bulk phase of the emulsion) or heat (such as from an igniter or promoter) would appear to be crucial to initiating the breaking of the emulsion.

6.4.3 Smoke Suppressants

The beneficial effects of adding certain organometallic compounds to fuels to reduce smoke have been recognized since the early 1960s (Salooja, 1972). The compounds that have been studied for use in engines and combustors include derivatives of barium, manganese, iron, lead, copper, magnesium, nickel, cobalt and boron. Of these, the compound that has been researched the most for oil spill use is ferrocene and its derivatives (Mitchell, 1990; Mitchell & Janssen, 1991; Mitchell & Moir, 1992; Moir *et al.*, 1993).

Ferrocene is the common name for bis-cyclopentadienyl iron with the formula $(C_5H_5)_2Fe$. It is a "sandwich" compound with the iron atom placed between two hydrocarbon rings. It is an orange-coloured, crystalline solid that is insoluble in water and slightly soluble in hydrocarbons up to about 2% to 4% by weight (Mitchell, 1990; Moir *et al.*, 1993). Its density is greater than that of water. Ferrocene is used commercially for many applications as an additive, including in rocket propellant to promote more efficient burning, as a smoke suppressant in diesel fuel, and in heating oils in Europe to reduce particulate emissions to regulated levels (Moir *et al.*, 1993).

Mitchell (1990) has proposed the following mechanism by which ferrocene inhibits soot formation. First, the ferrocene oxidizes to form microscopic iron oxide particles; the carbon then condenses out of the flame onto the iron oxide particles which act as nucleating centers. Finally, the carbon is oxidized by the iron oxide via:

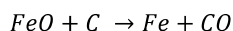

with the solid carbon converted to carbon monoxide rather than condensing into large soot agglomerates. Ferrocene is relatively non-toxic and is thus attractive for use on marine spills (Moir *et al.*, 1993).

Tests with ferrocene (Mitchell, 1990; Mitchell & Janssen, 1991) have shown that 90 to 95% reductions in soot production can be realized with the addition of 2% by weight ferrocene to the oil. The major difficulty with ferrocene powder is the fact that it dissolves slowly in oil and its density exceeds that of water. This makes it difficult to mix into an oil spill, and if the powder misses the slick it sinks.

Over 30 derivatives of ferrocene have been tested to overcome the application problems associated with ferrocene (Mitchell & Janssen, 1992; Mitchell & Moir, 1992; Moir *et al.*, 1993). The derivatives tested tend to be liquids at room temperature and are much more soluble in

oils than the parent ferrocene. Although the various derivatives have various degrees of effectiveness (as the formula weight increases the soot reduction per unit weight generally decreases) on a "per unit ferrocene" basis the derivatives are all of almost constant effectiveness (Mitchell & Moir, 1992). Mitchell & Moir (1992) discovered that the effectiveness, even on a "per unit ferrocene" basis was a function of the oil type. Moir *et al.* (1993) give a formula that relates likely soot reduction to the composition of the oil for one proprietary ferrocene derivative, RMS 9757:

$$\text{Soot reduction} = 1 - ((1.7P + 4.5N + 2A)/(1.8P + 7.2N + 16A)) \quad (6-1)$$

where:

- P = concentration of normal paraffins (wt%)
- N = concentration of branched hydrocarbons (wt%)
- A = concentration of aromatic hydrocarbons (wt%)

This equation predicts increased ferrocene derivative effectiveness with increasing aromatic and branched hydrocarbon concentration and with decreasing paraffin content.

Moir *et al.* (1993) report that one ferrocene hybrid, RMS 9757, reduces soot up to 70% at dose rates of 0.5 wt% ferrocene equivalent, is easily applied as a liquid concentrate that can be sprayed onto a slick, and dissolves quickly. The product has not yet been commercialized.

6.5 Herding Agents

The use of specific surface-active chemicals (surfactants), sometimes called oil herders or oil collecting agents, to clear and contain oil slicks on the surface of water is well known (Garrett & Barger, 1972; Rijkwaterstaat, 1974; Energetex, 1981; Pope *et al.*, 1985; MSRC, 1995). These agents have the ability to spread rapidly over a water surface into a monomolecular layer as a result of their high spreading coefficients, or spreading pressures. The best herding agents have spreading pressures in the mid-40 mN/m range, whereas most crude oils have spreading pressures in the 10 to 20 mN/m range. Consequently, small quantities of these surfactants (applied at about 15-L per linear kilometre of slick edge) will quickly clear thin films of oil from large areas of water surface, contracting the oil into thicker slicks.

Herders sprayed onto water surrounding an oil slick result in formation of a monolayer of surfactants on the water surface. These surfactants reduce the surface tension of the surrounding water considerably (from about 70 mN/m to 20-30 mN/m). When the surfactant monolayer reaches the edge of a thin oil slick it changes the balance of interfacial forces acting on the slick edge and allows the interfacial tensions to contract the oil into thicker layers. Herders do not require a boundary to "push against" and work even in unbounded open water. A conceptual drawing of the herding process is shown in [Figure 6-6](#). Although commercialized in the 1970s herders were not used offshore because they only worked in very calm conditions: physical containment booms were still needed to hold or divert slicks in wind speeds above 2 m/s, and breaking waves disrupted the herder layer. For application in loose pack ice, the intention is to herd freely-drifting oil slicks to a burnable thickness, then ignite them. The herders will work in conjunction with the limited containment provided by the ice to allow an extended window of opportunity for burning.

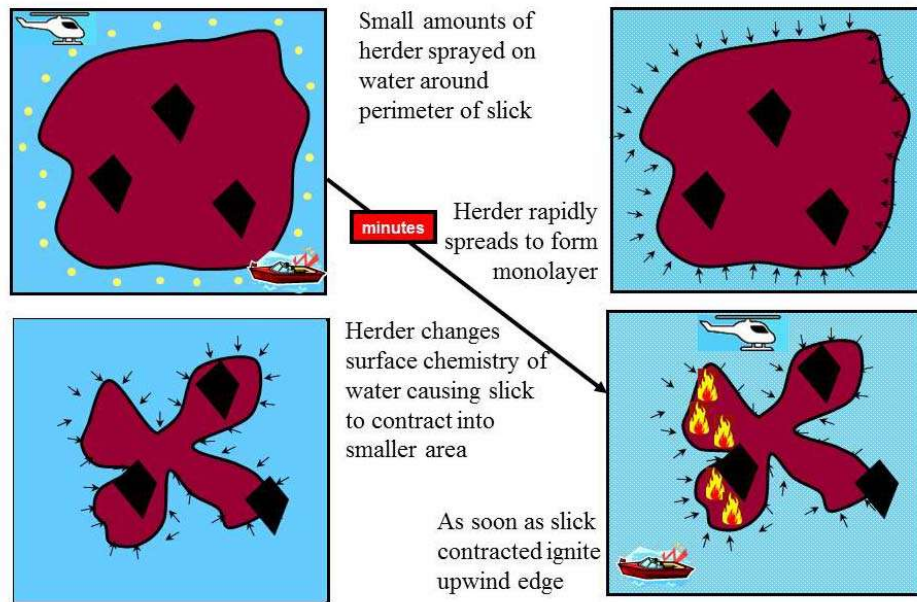

Figure 6-6 Concept for use of herders to contract oil slicks in drift ice for ignition and burning. (Source: SL Ross Environmental Research)

A research programme that began in 2003 to advance oil spill response in ice found that herding agents persisted long enough to enable in situ burning of relatively fresh, fluid oils in broken or drift ice. This multi-year, multi-partner programme (Buist *et al.*, 2011) consisted of the the following experiments and studies:

- A very small scale (1-m²) preliminary assessment of a shoreline-cleaning agent with oil herding properties was carried out in 2003 to assess its ability to herd different oils on cold water and among ice (SL Ross, 2004a).
- Additional small-scale (1-m²) experiments were carried out next in 2005 to explore the relative effectiveness of three oil hydrocarbon-based herding agents in simulated ice conditions; followed by larger scale (10-m²) quiescent pan experiments to explore scaling effects; small-scale (2 to 6-m²) wind/wave tank tests to investigate wind and wave effects on herding efficiency; and finally, small ignition and burn tests (SL Ross, 2005). These tests identified ThickSlick 6535 as an effective herding agent on cold water and in ice conditions.
- Experiments were done next with the ThickSlick 6535 herder at the scale of 100-m² in the indoor Ice Engineering Research Facility Test Basin at the U.S. Army Cold Regions Research and Engineering Laboratory (CRREL) in November 2005; at the scale of 1000-m² at OHMSETT in artificial pack ice in February 2006; and finally a series of 20 burn experiments (Figure 6-7) were carried out in 2006 with the ThickSlick 6535 herder at the scale of 30-m² in a specially prepared test basin containing broken sea ice in November 2006 at the Fire Training Grounds in Prudhoe Bay, AK with fresh crude oil (SL Ross, 2007).



Figure 6-7 Burn test with ThickSlick 6535 at Prudhoe Bay, AK in 2006. (Source: J. Mullin)

- Field tests in pack ice in the Barents Sea were done in 2008. One experiment involved the release of 630-L of fresh Heidrun crude in a large lead. The free-drifting oil was allowed to spread for 15-minutes until it was far too thin to ignite (0.4-mm), and then ThickSlick 6535 herder was applied around the slick periphery. The slick contracted and thickened for approximately 10-minutes at which time the upwind end was ignited using a gelled gasoline igniter. A nine minute long burn ensued (Figure 6-8) that consumed an estimated 90% of the oil (Buist et al., 2010a).
- Studies on better herding surfactants were completed between 2008 and 2010 (Figure 6-9). It was during this testing that the OP-40 silicone-based herder was identified as being more efficient at herding (Buist et al., 2010b).
- Work on developing techniques for applying herding agents to slicks in ice-affected water commenced in 2010 (Buist & Belore, 2011).
- Experiments of the use of herders as a rapid-response technique for use in open water were carried out in 2010 (SL Ross, 2012b), and showed that herders on open water could:
 - restrain a slick for more than 45-minutes in calm waters;
 - restrain a slick in a swell condition, but the constant stretching and contracting of the herded slick elongates the oil slick and slowly breaks it into smaller segments.



Figure 6-8 Burn of herded slick in Barents Sea pack ice lead (near start on left, near end on right). (Source: D. Dickins)



Figure 6-9 Testing of silicone-based herding agents at CRREL (far left shows oil release, Centre shows oil spread to equilibrium, Right shows contraction to new equilibrium after herder addition to water). (Source: SL Ross Environmental)

However, the presence of breaking or cresting waves rapidly disrupts the herder monolayer and the oil slick resulting in many small slicklets.

- Two herding agents (ThickSlick 6535 and OP-40) have been commercialized and placed on the U.S. EPA National Oil and Hazardous Substances Pollution Contingency Plan (NCP) Product schedule (<http://www.epa.gov/oem/content/ncp/index.htm#schedule>) for consideration for use in U.S. waters. Samples of these herders have also been submitted to Environment Canada for consideration for use in Canadian waters.
- A helicopter-borne application system for Arctic use is being developed and will be tested in late 2012 (Lane *et al.*, 2012)

6.6 Floating Burners and Incinerators

Although the subject of floating incinerators does not strictly fall under the purview of a report on in situ burning in ice-affected waters, many concepts for such devices have been proposed

for use in support of Arctic oil exploration and production, and as such, they are reviewed briefly here.

Ever since the *Torrey Canyon* spill, designs for the construction of floating burners have been proposed. The purpose of these has been twofold: to increase the amount of the heat of combustion that is radiated back to the slick; and to improve the mixing of combustion air with fuel.

6.6.1 Pittsburgh Corning Floating Incinerators

Two of the systems patented by Pittsburgh Corning are shown in **Figures 6-10** and **6-11**. Both concepts employ a system of oil wicking and radiant energy capture. As stated in Battelle (1979) for the first system:

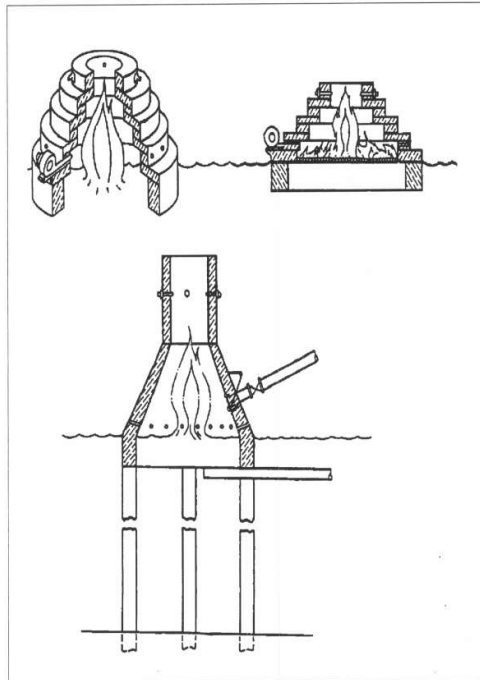

Floating oil spill furnace (from U.S. Patent 3,695,810 - October 3, 1972)

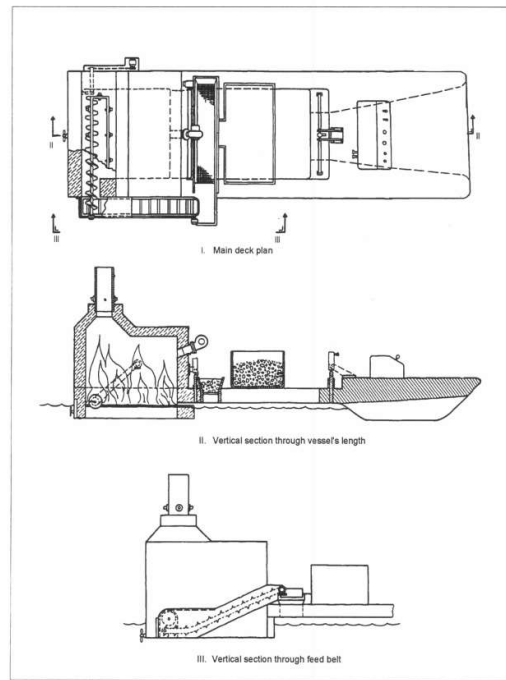

Oil spill incinerator vessel (from U.S. Patent 3,663,146 - May 16, 1972)

“Oil residues and emulsions floating on a body of water are burned by confining the layer of residue within a furnace chamber (Figure 6-10). The furnace is equipped with a combustion air inlet adjacent to the upper surface of the residue and a stack with inlets for combustible gas. The combustible gas burns the combustible material from pyrolysis of the liquid residue to provide a relatively smokeless combustion process. The furnace is fabricated from a refractory material having insulating properties so that a substantial portion of the heat given off by the combustion of the residue is retained within the furnace to propagate further combustion of the residue and aid in the complete combustion of the difficult to burn portions of the residue. The furnace is preferably fabricated from a material that permits the furnace to float partially

submerged in the body of water and may be easily transported from one location on the body of water to another location thereon. The furnace may be supported from suitable pipings and the residue conveyed directly into the furnace chamber."

*"For certain types of difficult to burn residues, a layer of cellular glass nodules (see SeaBeads above) with a textured outer surface is positioned to float on the upper surface of the residue within the furnace chamber." The Battelle (1979) report discussed the second Pittsburgh Corning system as such: "A generally V-shaped, buoyant, self-propelled vessel (**Figure 6-11**) floats partially submerged in a body of water and has a longitudinal channel portion with a front opening. The vessel has an open bottom portion beneath the longitudinal channel portion. As the vessel advances into a body of water, a band of water with the layer of combustible liquid floating thereon enters the channel of the vessel. The rate at which the combustible liquid, as a layer, enters the channel is dependent on the forward speed of the vessel. This speed is controlled so that substantially all of the liquid is removed by burning before the band of water passes under the rear or exit portion of the vessel. As the vessel advances, the band of water with the layer of combustible liquid moves through a mixing chamber within the channel portion where a monolayer of cellular ceramic nodules are positioned on the top surface of the layer of combustible liquid. The layer of combustible liquid with the nodules floating thereon moves toward the rear with the forward advance of the vessel. The oil moves into a combustion chamber where it is ignited and burned. The glass nodules within the combustion chamber are recycled to the mixing chamber where they are re-positioned as a monolayer on the upper surface of the layer of combustible liquid. Combustion air is provided for the combustion chamber and the combustion gases can be subjected to a secondary burning in the stack to remove the combustible materials in the gases to provide a substantially smoke-free waste gas. Apparatus is provided to seal the combustion chamber and mixing chamber if the burning of the combustible liquid tends to spread beyond the receiver."*

Neither of these concepts was pursued commercially.

6.6.2 BP Elijah Burner

Some of British Petroleum's oil burning investigations were conducted in the late 1960s when the burner called "Elijah" was created. This burner (Figure 6-12) formed a concentrated pool within the lower part of the burner by a vortex-forming, submerged pump. The oil would accumulate to several inches thick and was continuously thrown as a spray up into the upper part of the inverted cone-shaped burner in a stream of hot air. The burner, which was 1.5-m wide x 3-m long x 2-m high, consumed about 40 L/h in a highly



Figure 6-12 BP "Elijah" burner during tests. (Source: MSRC)

luminous, minimal smoke producing manner. Burning continued even though oil surrounding the burner was substantially less than 2-cm thick. British Petroleum wished to handle 100 tonnes/h; therefore, this system was abandoned for other physical removal systems.

6.6.3 Pipeline Rupture Burner (adapted from Battelle, 1979)

"Another system which may have application is illustrated in Figure 6-13. This system illustrates a method that is proposed to prevent oil pollution of water in the vicinity of an offshore production operation. The apparatus is provided for use on a ruptured oil and/or natural gas pipe where fluid is issuing under pressure from the pipe. A heat dissipating screen is disposed in the path of the fluid and raised to a predetermined position. The fluid is then intentionally ignited (thus preventing pollution), and the heat dissipating effect of the screen confines the flame to a region above the screen spaced from the open end of the well pipe. A thermal radiation shield can be provided in addition to water cooled members for the screen and shield."

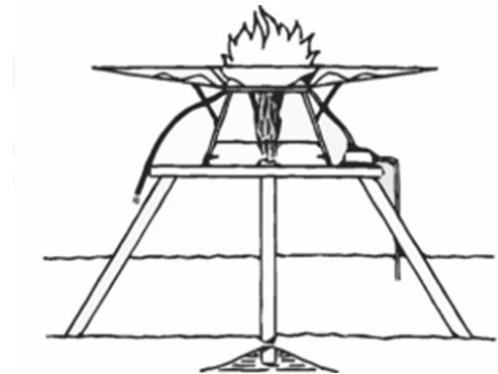

Figure 6-13 Combustion system for pipeline leaks (Source: U.S. Patent 3,602,299 - August 31, 1971)

This device was never developed beyond the design stage.

6.6.4 Dome Sub-Sea Blowout Burner

Dome Petroleum researched a device that could be deployed over a subsea blowout and used to collect and burn off the oil and gas (Figure 6-14). The idea was to position an inverted cone collector over the blowing well so as to direct oil, gas and water to the surface by flexible risers. The oil/gas and water mix would enter the bottom of a floating, ice-strengthened burner where the oil and gas would be combusted. Preliminary designs, load studies and scale-model burn

tests were conducted on the idea; however, it was never constructed because of the high capital cost compared with the low probability of occurrence of a subsea oil well blowout (Buist & Potter, 1982).

6.6.5 *Continuously-Burning Wicking Devices*

Twardus (1978) reports on the development and testing of a small (2 L/h) burner that could be aerially deployed onto small slicks in remote areas. The devices (**Figure 6-15**) would ignite in the presence of oil and slowly burn off surrounding oil. The wicking blanket would provide a steady supply of oil to a drip-type burner that combusted the oil without igniting the surrounding slick. Materials were selected and several prototypes constructed and tested but the concept was abandoned in favour of aerial igniter techniques.

6.6.6 *Acoustic Burner*

Since the mid-1970s acoustical energy has been known to lift oil off the surface of water (Curzon & Ahlborn, 1978). The use of focused acoustic energy atomizes the oil and allows it to be burned in a floating incinerator (Koblanski, 1981, 1983, 1985). One such concept (**Figure 6-16**) was constructed and tested (Koblanski, 1983; Lipski, 1986). Tests by Environment Canada concluded that the transducer was too sensitive to position it to be effective in a wave environment and that the oil droplets created were too large (ca. 5-mm) for efficient burning (Lipski, 1986; Caron, 1988). Incorrectly positioning transducers also rapidly emulsified the oil.

6.6.7 *Air Jet Atomizing Burner*

As a result of work on acoustical methods of atomizing oil directly off the water, the concept of using submerged pneumatic nozzles to entrain and atomize oil was researched (Lipski, 1986; Caron, 1988; Belore & Seeley, 1990). The concept involved positioning a simple pneumatic jet near the oil/water interface. The jet is oriented vertically upward and draws oil to it, entrains the oil and atomizes it.

Tests (Lipski, 1986; Caron, 1988; Belore & Seeley, 1990) showed that:

- If the nozzle was placed deeper than 2-cm below the water surface no atomization occurs - a spout of mostly water was created;
- With the nozzle in the water within 2-cm of the water surface atomization occurred but water contents ranged from 80 to 100%;
- With the nozzle at the oil/water interface or in the oil the water content reduced - with a 0.5-mm thick slick the water content was 50%, with 2 and 4-mm thick slicks the water content was less than 10%; and

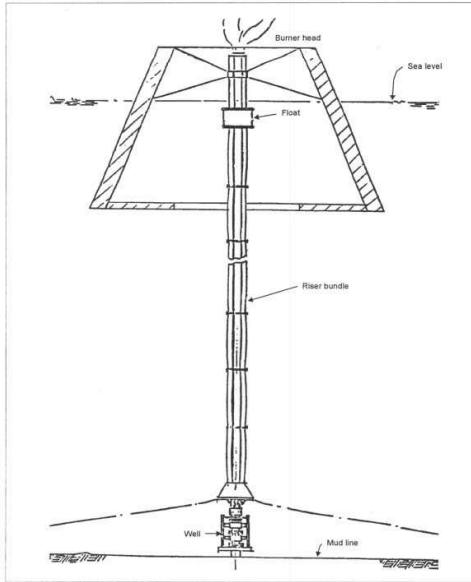
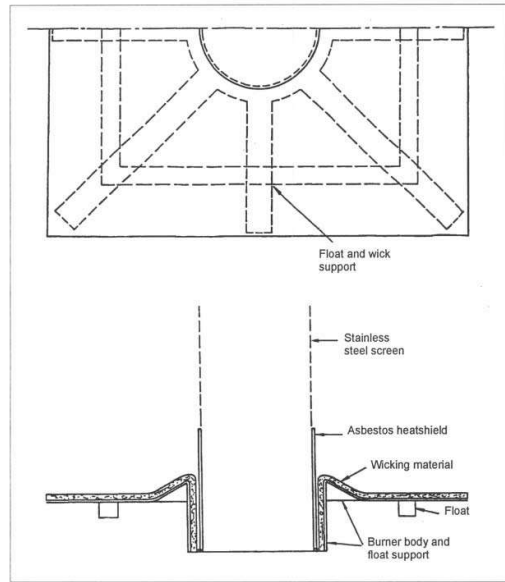

Figure 6-14 Dome subsea blowout burner. (From Buist & Potter, 1982)



Wicking burner. (From Twardus, 1978)

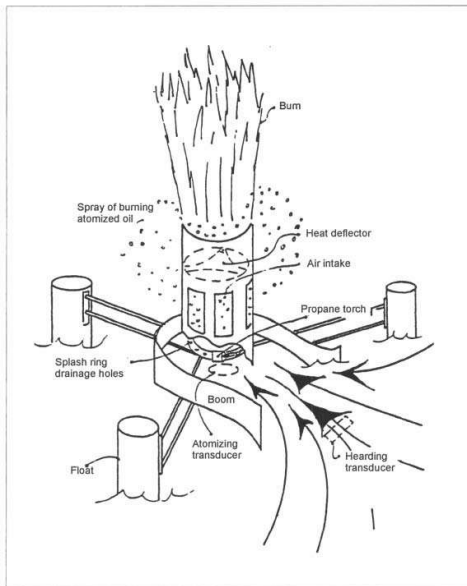
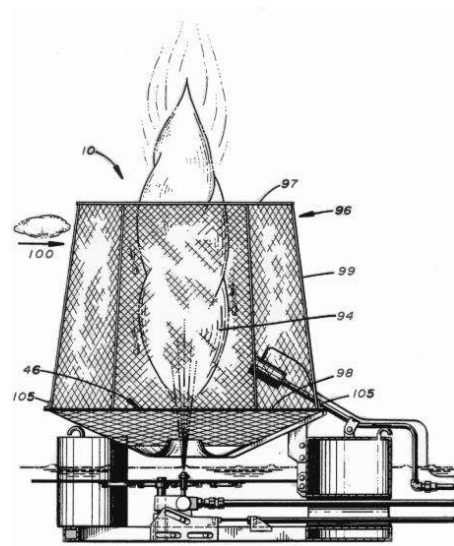

Figure 6-16 Combination of oil herding and atomizing device. (Source: MSRC)



Sprayburn floating oil burner. (From U.S. Patent 5,057,004 - October 15, 1991)

- Larger diameter nozzles and reduced pressure (from 275 to 140 kPa) increased the oil atomization rate. The maximum oil uptake rate measured was 1.75 L/min for one 6-mm diameter nozzle with an air pressure of 140 kPa in 4-mm of oil.

Tests of a fixed burner with 6-mm diameter nozzles were conducted in a tank (Belore & Seeley, 1990). A stack (or chimney) was supported 15-cm above the water surface with five 6-mm nozzles arranged beneath it at the water surface. Slick thicknesses of 2-mm and air pressures of 200 to 600 kPa were used. The test results indicated that the method had merit and could

produce reduced smoke levels if operating parameters were correctly maintained; the most crucial of these was keeping the nozzles positioned in the oil layer just above the oil/water interface. Optimum burn conditions were realized at an air pressure of 415 kPa; a 5 L/min burn rate was achieved. It was noted that the slick beneath the burner always ignited and, if the burner was in slicks greater than 1 to 3-mm thick the fire would spread to the surrounding oil slick engulfing the burner in flames. The air jet atomization technique was further engineered and commercialized by Sprayburn Systems Inc. Their device (Figure 6-17; previous page) incorporates a single, controllable height nozzle mounted in a floating, disc-shaped burner. A propane ignition system is also incorporated into the design. No test data are available.

6.6.8 University of Arizona Burners

In the early 1990s, research was undertaken on methods to enhance in situ combustion of oil on water (Franken *et al.*, 1992) by mechanically enhancing air entrainment into the combustion zone. Any buoyant column of heated rising air or hot combustion gases tends to have a swirl component, commonly referred to as the "Fire Whirl". This is a desirable effect as it encourages the entrainment of surrounding air and thereby increases aeration at the center of the flames. Several approaches to augmenting this fire whirl have been studied.

One method involves deploying sheet metal vanes about a burning pool in order to guide the in-flowing air into a cyclonic pattern (Figure 6-18). Experiments performed in 0.6-m, 1.2-m, and 2.4-m diameter pools 10-cm deep indicate that the addition of vanes increased the flame height by 200%, produced 50% less smoke and burned faster and more efficiently than identical experiments performed without the vanes (Franken *et al.*, 1992). Tests were also carried out with both curved (semi-circular) and straight fins; no significant difference was found. It was determined that the vanes definitely helped augment the combustion by supplying additional air to the center of the blaze, but the configuration or shape of the vanes seemed to have little impact on the combustion rate. The effect of burn pan depth was not investigated.

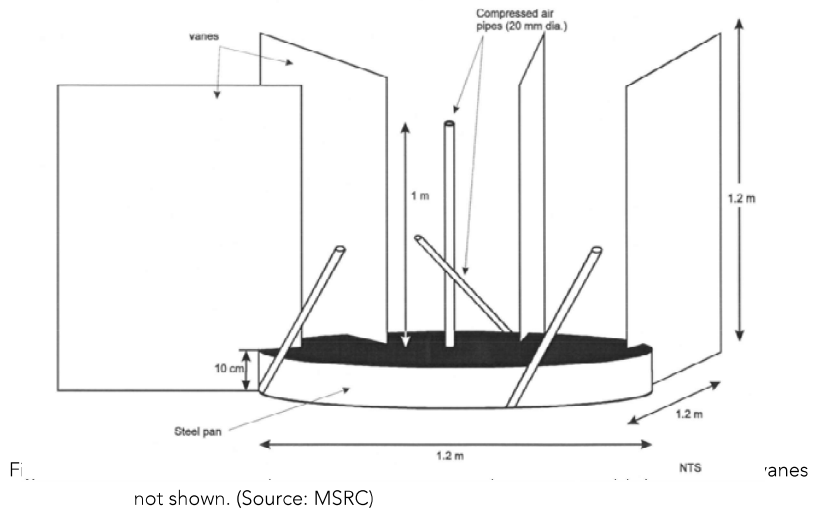

For the most successful runs, each container used eight vanes, mounted on, and arranged tangentially to, the top of the containment pool, with their dimensions being 0.6-m x 0.4-m, 1.2-m x 1.2-m, and 1.2-m x 1.8-m respectively. However, Alaska Clean Seas tested the use of vanes around a burn test of fire resistant boom in a large tank (ACS, 1991) and found no induced vortex and no reduction in smoke.

Several experiments designed to determine an effective method of augmenting the ducting effect described above were performed by Franken *et al.* (1992) from May through September 17, 1990. It was concluded from these experiments that it was not effective in practice to supply all the stoichiometric air needed for combustion using low velocity, high volume air blowers; rather, it would be more efficient to have other processes in place which would increase the natural flow of air (the Fire Whirl) into the combustion zone. The conclusion of the report was that "the addition of a few hundred cfm of compressed air is more utilitarian than the addition of more than 50,000-cfm of low velocity streams" (Franken *et al.*, 1992).

An effective arrangement for the 1.2 -diameter pool with the vane ducting structure, as described above, was to employ four low volume ($8\text{-m}^3/\text{min}$ in total), high velocity (high pressure) air jets, with one placed about 1-m above the liquid surface, aimed straight up the axis of the flames, and the remaining three each placed about 0.6-m from the central axis, a few feet above the liquid and canted by some 30° from vertical (Figure 6-19). These jets produced a "cyclonic" or "whirling" action within the flame in the same rotational sense as produced by the external vanes. The addition of the high velocity air increased the burning rate by about three and one half times, over that of the ducting alone (Franken *et al.*, 1992).

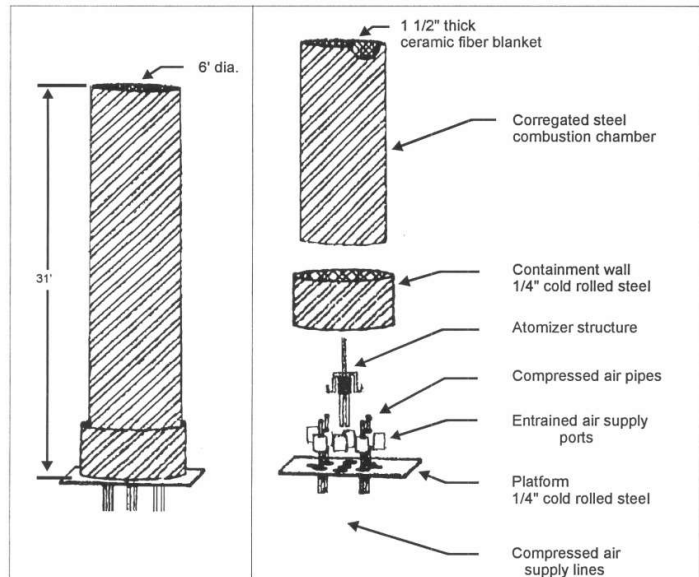

Figure 6-19 Two-metre diameter incinerator. (From Franken *et al.*, 1992)

The final incineration idea developed and tested by Franken *et al.* (1992) was a variation of the air jet atomizer described above. A refractory lined, 1.8-m diameter culvert 9.4-m in length was positioned vertically over a series of compressed air nozzles (Figure 6-20). Several nozzles directed air downwards at the oil/water interface to create a spray of oil for burning while

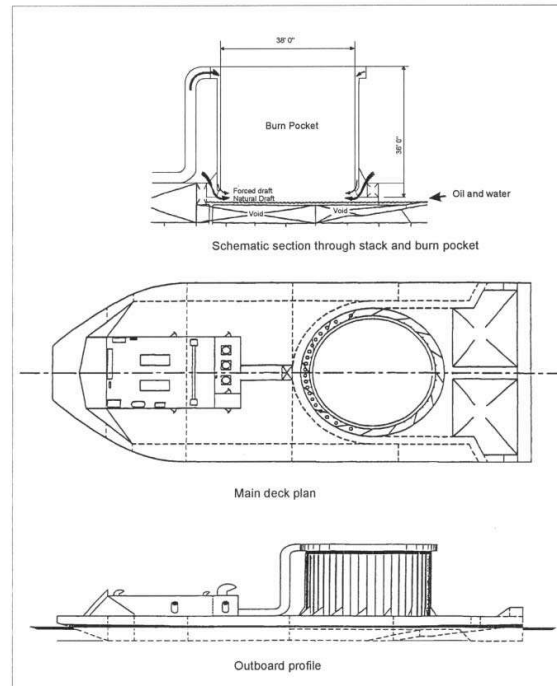

Figure 20-20 Conceptual sketch of seagoing incinerator. (Adapted from Franken *et al.* 1992)

others were directed tangentially upward to induce swirling in the combustion chamber. Tests with an 18-cm thick slick of crude oil on 25-cm of water resulted in an average burn rate of 95 L/min (24 mm/min); peak burn rates were estimated at 280 L/min (60 mm/min). Temperatures in the stack peaked at 1650°C, well above normal in situ burning flame temperatures (Franken *et al.* 1992). A conceptual design for a floating model of the incinerator to be connected to a skimming system was proposed (Figure 6-20); no further development of this concept was undertaken until recently (see below).

6.6.9 Arctic Environment Incinerator Barge

In 1990, Shell Western E&P in Alaska undertook a study of the concept of a floating incinerator capable of concentrating and burning spilled oil in open-water and broken-ice conditions typical of the Chukchi and Beaufort Seas (Glosten *et al.*, 1991). The final design concept (Figure 6-21) incorporates an ice-strengthened barge and a double-wall incinerator. The barge is designed to be towed forward to the spill site then operated aft-first. Oil would be directed to the stern of the barge into the cylindrical, 11-m diameter, 10.3-m high incinerator. The incinerator would be of a double wall design (Figure 6-21) whereby cool air is pumped in the top and travels downwards through the shell to exit at the bottom and provide swirling action and preheated combustion air. The incinerator shell would be supported on the barge by slanted vanes that permit the entrainment of air under the shell and also give it a rotational moment



General arrangement of Arctic incinerator barge. (From Glosten *et al.*, 1991)

to help air/fuel mixing (as per the work of Franken *et al.*, 1992 noted above). No testing or further design work on the concept has been undertaken.

6.6.10 Radiative Evaporation

Summerfield (1993) has proposed the use of a high temperature (1130°C) radiator powered by natural gas to vaporise oil (but not burn the vapours). The radiator would be mounted on a boat trailing the apex of the boom; this boat would also carry the compressed natural gas supply. Summerfield (1993) estimates that it would require about 5-hours to evaporate 4,000-L of oil. Besides low capacity concerns, the concept presents several fire hazard and emissions concerns.

6.6.11 Testing Augmented In Situ Combustion

In June 1995, MSRC conducted a series of large-scale pan burn tests to examine the use of various air injection techniques to reduce smoke emissions from *in situ* burning (Nordvik *et al.*, 1995). The techniques tried were compressed air injection via canted nozzles and an underwater bubbler. The most successful system was the compressed air injection system. **Figure 6-22** shows a pan burn with no air injected and **Figure 6-23** shows a pan burn with 66 m³/min of compressed air injected into the fire from five 4-cm diameter nozzles (four canted 45° in a clockwise direction and one straight up in the center of the burn). The burn rate was



Figure 6-22 Burn test with no aeration. (Source: MSRC)



Burn test with compressed air nozzle aeration. (Source: MSRC)

increased from 3.5 to almost 5 mm/min using this technique; however, the system was very susceptible to wind. Even a slight breeze would move the fire away from the influence of the compressed air nozzles and cause an increase in smoke and decrease in burn rate. The use of a

submerged bubbler did reduce smoke emissions, but also greatly reduced the burn rate and increased residues.

6.6.12 Technology Assessment and Concept Evaluation for Alternative Approaches to In Situ Burning

In 1998 Marine Research Associates produced a study examining alternatives to the use of fire booms to burn oil offshore. Of particular relevance to the present study was the development of two barge-based concepts for use on longer-term offshore spills (e.g., blowouts): one with a simple burn area created by removing portions of the center tanks of an existing oceangoing barge (Figure 6-24) and the second (Figure 6-25) a custom-designed barge with an enhanced air flow system built in (similar to the Glosten & Franken concepts discussed above).

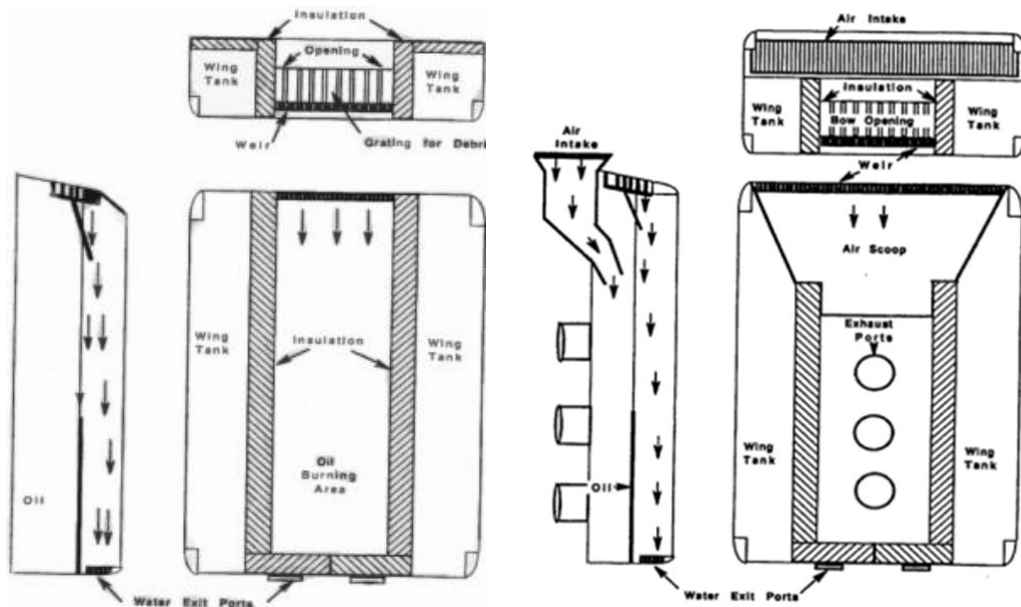

Figure 6-24 Simple, modified existing barge hull concept. (Source: Marine Research Associates)

Purpose-built barge with enhanced combustion air. (Source: Marine Research Associates)

6.6.13 Research on Combining an Oleophilic Skimmer and Floating Burner for One-Step Offshore Oil Removal

During the 2010 DWH spill response in the Gulf of Mexico, vessels of opportunity (i.e., shrimp boats) were employed to collect oil that had not been intercepted by the large skimming and in situ burning systems deployed near the well site, nor chemically dispersed. The vessels of opportunity used short sections of boom deployed on outriggers to collect oil and emulsion for recovery. Once the oil booms were full, these vessels of opportunity had to wait for a skimmer vessel to come and recover the oil. This concept would have direct applicability to oil recovery operations in ice-affected waters.

A research project, initiated in 2011, studied the feasibility of a combined skim and burn system concept utilizing a floating burner towed behind the recovery booms. This would allow vessels

of opportunity to become more effective oil spill response systems and also allow normal containment and recovery systems to avoid the time-consuming and expensive steps of storing, transferring, and disposing of recovered oil. The concept relies on the fact that properly operated oleophilic skimmers do not entrain much water and the recovered oil could be immediately burnable. Even if the recovered fluid were emulsified, in situ treatment of the collected oil with emulsion breakers could reduce the emulsion water content down to an ignitable range.

The objective of the research was the development of a small, floating burner that can combust oil at rates matching those recovered by small oleophilic skimmers and do so more efficiently (i.e., with less smoke emitted and minimal residue) than the oil could be burned in situ on water. The work involved two scales of experiments that included the design, construction, and testing of model burner concepts (Cooper *et al.*, 2012).

Figure 6-26 shows the bench-scale model being tested in an indoor wave tank. The burner consisted of a support frame, burning ring with mesh containment screen, and a stack. Compressed air was introduced via stainless steel rods with a hollow core approximately 3-mm in diameter. Three of the rods were configured at an angle to the walls to help induce a swirling motion within the stack. A fourth rod was installed low in the middle of the stack to help contribute to



Figure 6-26 Small-scale floating burner test in an indoor wave tank. (Source: SL Ross Environmental Research)

the atomization of oil during the burn tests. The burn support frame was submerged in a test tank for the test runs, holding the burner and stack at the water interface during the burns. The stack was a commercially available 5-inch stainless steel, double walled chimney with a refractory lining terminated in a stainless steel gasket to protect the liner.

The mid-scale burn unit included a supported chimney with a 16-inch diameter. The height of the chimney was 122-cm. Mounted on the inside base of the burner were three stainless steel air injection nozzles, each with an inner diameter of approximately 9.5-mm oriented towards the inner walls of the chimney. The nozzles were mounted at an angle of approximately 30° from vertical. A stainless steel cup was mounted at the center of the chimney base with inlet piping to allow oil to be introduced as the unit was actively burning. A 16-inch burning ring was installed at the waterline to contain oil during the experiments. In addition, a curved section of steel tubing with small holes strategically drilled to act as upward-pointing oil atomizing nozzles was fastened just below the lip of the stainless steel cup. **Figure 6-27** shows the mid-scale

burner model during an outdoor test. The burner was fed by an oleophilic rope mop skimmer for several of these tests.



Figure 6-27 Mid-scale burner model during outdoor tests. (Source: SL Ross Environmental Research)

The system worked well, successfully demonstrating the basic concept of combining an oleophilic skimmer and a floating burner. The processing rate of the system consumed oil at a rate in excess of 20-mm per minute during its best test run. When the 20-mm per minute rate is scaled up to a 1.83-m diameter burn, oil would be burned at a volumetric rate of 3.16-m³/h (20 bbl/h).

References to Chapter 6

- ASTM. 2012. F2084 Standard Guide for Collecting Containment Boom Performance Data in Controlled Environments; F2152-07 Standard Guide for In Situ Burning of Spilled Oil: Fire-Resistant Boom. ASTM Annual Book of Standards. ASTM West Conshohocken, PA, U.S.
- Alaska Clean Seas (ACS). 1991. Long Duration Test Burn: 3M 8-Inch Fire Containment Boom. *ACS Newsletter*, 1(1), March 31, 1991. Anchorage, AK, U.S.
- Allen, A.A. 1986a. Test and evaluation of fire containment boom. Report to Alaska Clean Seas, Anchorage, AK, U.S.
- Allen, A.A. 1986. Alaska Clean Seas survey and analysis of air-deployable igniters. In: *Proceedings of the Ninth Arctic and Marine Oilspill Program (AMOP) Technical Seminar*, June 10-12, Edmonton, AB. Environment Canada, Ottawa, ON, Canada, pp. 353-373.

- Allen, A.A. 1987. Refinement of Aerial Ignition Systems (Test and Evaluation of the Heli-Torch for the Ignition of Oil Slicks). Report to Alaska Clean Seas, Anchorage, AK, U.S.
- Allen, A.A. 1990a. Contained Controlled Burning of Spilled Oil During the Exxon Valdez Oil Spill. In: *Proceedings of the Thirteenth Arctic and Marine Oilspill Program (AMOP) Technical Seminar*, June 6-8, Edmonton, AB. Environment Canada, Ottawa, ON, Canada, pp. 305-313.
- Allen, A.A. 1990b. Contained Controlled Burning of Spilled Oil During the Exxon Valdez Oil Spill. *Spill Technology Newsletter*, 15(2):1-5.
- Allen, A.A. and E.M. Fischer. 1988. Test and Evaluation of a New and Unique Fire Containment Boom. In: *Proceedings of the Eleventh Arctic and Marine Oilspill Program (AMOP) Technical Seminar*, June 7-9, Vancouver, BC. Environment Canada, Ottawa, ON, pp. 185-199.
- Allen, A.A. 1991a. Controlled Burning of Crude Oil On Water Following the Grounding of the Exxon Valdez. In: *Proceedings of the 1991 Oil Spill Conference*, March 4-7, San Diego, CA. American Petroleum Institute, Washington, DC, U.S., pp. 213-216.
- Allen, A.A. 1991b. In Situ Burning of Spilled Oil. *Spill Technology Newsletter*, 16(4):1-12.
- Allen, A.A. 1992. In Situ Burning Field Operations Manual. 3M Ceramic Materials Department, St. Paul, MN, U.S.
- Allen, A.A. 1999. New Tools and Techniques for Controlled In Situ Burning. In: *Proceedings of the 22nd Arctic and Marine Oilspill Program (AMOP) Technical Seminar*, Environment Canada, Ottawa, ON, Canada, p. 613.
- Allen, A.A., N.J. Mabile, D. Costanzo, and A. Jaeger. 2011. The Use of Controlled Burning during the Gulf of Mexico Deepwater Horizon MC-252 Oil Spill Response. In: *Proceedings of the 2011 International Oil Spill Conference (IOSC)*, Portland, OR, American Petroleum Institute, Washington, DC, U.S.
- Anonymous. 1967. Chemicals vs. Crude Oil. *Chemical Week*, 100(20):49.
- Anonymous. 1968. A Product that is an Irritant in Chemical Warfare can also Combat Ocean Oil Spills. *Chemical Engineering*, 75(26):54.
- Anonymous. 1970. Materials Applications. *Industrial Research*, 12(3):67-68.
- Arctec Canada Ltd. 1977. Novel Countermeasures for an Arctic Offshore Well Blowout. Report No. EPS-3-EC-77-14: Fisheries and Environment Canada, Ottawa, ON, pp. 18-24.
- Battelle. 1979. Combustion: An Oil Spill Mitigation Tool. Report for U.S. Department of Energy, Contract No. EY-76-C-06-1830, U.S. Dept. of Energy, Washington, DC, U.S.
- Bech, C., P. Sveum, and I.A. Buist. 1992. In Situ Burning of Emulsions: the Effects of Varying Water Content and Degree of Evaporation. In: *Proceedings of the Fifteenth Arctic and Marine Oilspill Program (AMOP) Technical Seminar*, June 10-12, Edmonton, AB. Environment Canada, Ottawa, ON, Canada, pp. 547-559.
- Bech, C., P. Sveum, and I.A. Buist. 1993. The Effect of Wind, Ice and Waves on the In Situ Burning of Emulsions and Aged Oils. In: *Proceedings of the Arctic and Marine Oilspill Program (AMOP) Technical Seminar*, 16(2):735-748. Environment Canada, Ottawa, ON, Canada.
- Beckett, C.J. 1979. The Grounding of the *Imperial St. Clair* - a Case History of Contending with Oil in Ice. In: *Proceedings of the 1979 Oil Spill Conference*, March 19-22, New Orleans, LA. American Petroleum Institute, Washington, DC, U.S., pp. 371-375.
- Belore, R.C. and C. Seeley. 1990. Air Jet Atomization and Burning of Oil Slicks. In: *Proceedings of the Thirteenth Arctic and Marine Oilspill Program (AMOP) Technical Seminar*, June 6-8, Edmonton, AB. Environment Canada, Ottawa, ON, Canada, pp. 289-304.
- Bitting, K., J. Gynther, M. Drieu, A. Tidemann, R. Martin. 2001. In situ burn operational procedures development exercises. Proc. of the 24th Arctic and Marine Oilspill Program Technical Seminar, p695. Environment Canada, Ottawa, ON, Canada.
- Bitting, K.R. and P.M. Coyne. 1997. Oil Containment Tests of Fire Booms. In: *Proceedings of the 20th Arctic and Marine Oilspill Program (AMOP) Technical Seminar*. Environment Canada, Ottawa, ON, Canada, 735 p.

- Borst, M. 1983. GEMENG Lightweight Fireproof Boom: Oil Containment Testing at OHMSETT. Report No. EPS 4-EP-83-5, Environment Canada, Ottawa, ON, Canada, 18 p.
- Buist, I.A. and S. Potter. 1982. Sub-Sea Containment: COOSRA Research to Date. In: *Proceedings of the Fifth Arctic and Marine Oilspill Program (AMOP) Technical Seminar*, June 15-17, Edmonton, AB. Environment Canada, Ottawa, ON, Canada, pp. 129-150.
- Buist, I., S. Potter, J. McCourt, P. Lane, P. Newsom, L. Hillenbrand, and S. Buffington. 1999. Re-Engineering of a Stainless Steel Fire Boom for use in Conjunction with Conventional Fire Booms. In: *Proceedings of the 22nd Arctic and Marine Oilspill Program (AMOP) Technical Seminar*. Environment Canada, Ottawa, ON, Canada, p. 545.
- Buist, I., W. Pistruzak, and D. Dickins. 1981. Dome Petroleum's Oil and Gas under Sea Ice Study. In: *Proceedings of the Fourth Arctic and Marine Oilspill Program (AMOP) Technical Seminar*, June 16-18, Edmonton, AB. Environment Canada, Ottawa, ON, Canada, pp. 647-686.
- Buist, I.A., S.G. Potter, and D.F. Dickins. 1983a. Fate and Behaviour of Water-In-Oil Emulsions in Ice. In: *Proceedings of the Sixth Arctic and Marine Oilspill Program (AMOP) Technical Seminar*, June 14-16, Edmonton, AB. Environment Canada, Ottawa, ON, Canada, pp. 263-279.
- Buist, I.A., W.M. Pistruzak, S.G. Potter, N. Vanderkooy, and I.R. McAllister. 1983b. The Development and Testing of a Fireproof Boom. In: *Proceedings of the Sixth Arctic and Marine Oilspill Program (AMOP) Technical Seminar*, June 14-16, Edmonton, AB. Environment Canada, Ottawa, ON, pp. 70-84.
- Buist, I., J. McCourt, and J. Morrison. 1997. Enhancing the in situ burning of five Alaskan oils and emulsions. 1997 International Oil Spill Conference Proceedings. April 7-10. Fort Lauderdale, FL, U.S., pp. 121-129.
- Buist, I.A., J. McCourt, J.V. Mullin, N.W. Glover, C. Hutton, and J. McHale. 1998. Mid-Scale Tests of In Situ Burning in a New Wave Tank at Prudhoe Bay, Alaska. In: *Proceedings of the Arctic and Marine Oilspill Program (AMOP) Technical Seminar*, 2(21):599-622. Environment Canada, Ottawa, ON, Canada.
- Buist, I., S. Potter, J. McCourt, P. Lane, P. Newsom, L. Hillenbrand, and S. Buffington 2001b. Re-Engineering of a Stainless Steel Fire Boom for use in Conjunction with Conventional Fire Booms. In: *Proceedings of the 2001 International Oil Spill Conference (IOSC)*. American Petroleum Institute, Washington, DC, U.S., pp. 533-538.
- Buist, I., J. McCourt, J. Morrison, J. Lane, J.V. Mullin, B. Schmidt, D. Devitis, K.L. Nolan, J. Stahovec, B. Urban, and C. Moffatt. 2001a. Fire Boom Testing at OHMSETT in 2000. In: *Proceedings of the 24th Arctic and Marine Oilspill Program (AMOP) Technical Seminar*. Environment Canada, Ottawa, ON, Canada, 707 p.
- Buist, I.A. 2005. Preliminary Screening of the Potential for Sodium Silicide to Ignite Oil Slicks. ExxonMobil Upstream Research, Houston, TX, U.S.
- Buist, I.A., S. Potter, and S.E. Sørstrøm. 2010a. Barents Sea Field Test of Herder to Thicken Oil for In Situ Burning. In: *Proceedings of the Thirty-third Arctic and Marine Oilspill Program (AMOP) Technical Seminar on Environmental Contamination and Response*. Environment Canada, Ottawa, ON, Canada, pp. 725-742.
- Buist, I.A., T. Nedwed, and G. Canevari. 2010b. New Herding Agents for Thickening Oil Slicks in Drift Ice for In Situ Burning. In: *Proceedings of the Thirty-third Arctic and Marine Oilspill Program (AMOP) Technical Seminar on Environmental Contamination and Response*, Environment Canada, Ottawa, ON, Canada.
- Buist, I.A. and R. Belore. 2011. Herding Agent Field Application System Development. In: *Proceedings of the Thirty-fourth Arctic and Marine Oilspill Program (AMOP) Technical Seminar on Environmental Contamination and Response*. Environment Canada, Ottawa, ON, Canada.
- Buist, I.A., S. Potter, T. Nedwed, and J. Mullin. 2011. Herding Surfactants to Contract and Thicken Oil Spills in Pack Ice for In Situ Burning. *Cold Regions Science and Technology*, 67:3–23.
- Burns, R.C. 1988. Cleanup and Containment of a Diesel Fuel Spill to a Sensitive Water Body at a Remote Site Under Extreme Winter Conditions. In: *Proceedings of the Eleventh Arctic and Marine Oilspill Program (AMOP) Technical Seminar*, June 7-9, Vancouver, BC. Environment Canada, Ottawa, ON, Canada, pp. 209-220.

- Cabioc'h, F. 1993. Last French Experiments in order to Evaluate the Burning Possibilities of Three Water-In-Oil Emulsions. In: *Proceedings of the Sixteenth Arctic and Marine Oilspill Program (AMOP) Technical Seminar*, June 7-9, Calgary, AB. Environment Canada, Ottawa, ON, Canada.
- Caron, P. 1988. Atomization Methods for Burning Oil Spills. Department of Civil Engineering and Applied Mechanics, McGill University, Montreal, QB, Canada, 29 p.
- Comfort, G. (Fleet Technology Ltd.). 1989. Tests to Evaluate the Effect of a Water Jet Barrier on the Burning Efficiency of a Floating Oil Slick. Environment Canada Report EE-112, Environment Canada, Ottawa, ON, Canada.
- Comfort, G., B. Menon, and W. Purves. 1979. The Feasibility of Pneumatic and Water Spray Barriers as Fireproof Oil Slick Containment Devices. *Spill Technology Newsletter*, 4:93-110.
- Cooper, D.W., I.A. Buist, R. Belore, T.J. Nedwed, and A. Tidwell. 2012. One-step Offshore Collection and Removal: Combining an Oleophilic Skimmer and Floating Burner. In: *Proceedings of the Thirty-fifth Arctic and Marine Oilspill Program (AMOP) Technical Seminar on Environmental Contamination and Response*, Environment Canada, Ottawa, ON, Canada, pp. 537-550.
- Coupal, B. 1972. Use Of Peat Moss in Controlled Combustion Technique. Environment Canada Report No. EPS 4-EE-72-1, Environment Canada, Ottawa, ON, Canada, 32 p.
- Coupal, B. 1976. Controlled Combustion Tests Carried out near Rimouski. Environment Canada Report EPS-4-EC-76-2, Environment Canada, Ottawa, ON, Canada.
- Curzon, F. and B. Ahlborn. 1978. Oil Removal System using Acoustical Radiation. Unpublished report to Environment Canada, Ottawa, ON, Canada.
- Det norske Veritas. 1979. Tanker Oil Spill Analysis Study. Technical Report for Canadian Marine Drilling Limited. Det norske Veritas Ship Division.
- Dome Petroleum Ltd. (Dome). 1981a. Fire Proof Boom Development - OHMSETT Trials. Dome Petroleum Ltd., Calgary, AB, Canada, 27 p.
- Dome Petroleum Ltd. (Dome). 1983. Fireproof Boom Field Testing. COOSRA Report. Dome Petroleum Ltd., Calgary, AB, Canada.
- Dome Petroleum Ltd. (Dome). 1981b. Oil and Gas under Sea Ice. Final report Volume one, Report to COOSRA. Calgary, AB, Canada.
- Energetex Engineering (Energetex). 1978. Testing of Air-Deployable Incendiary Devices for Igniting Oil on Water. Report No. EPS-4-EC-78-11, Environment Canada, Ottawa, ON, 98p.
- Energetex Engineering (Energetex). 1979. A Review of Oil Slick Combustion Promoters. Environment Canada Report EPS-3-EC-79-8, Environment Canada, Ottawa, ON, Canada, 48 p.
- Energetex Engineering (Energetex). 1980. A Study to Evaluate the Combustibility and Other Physical and Chemical Properties of Aged Oils and Emulsions. Report to Environment Canada, Ottawa, ON, Canada.
- Energetex Engineering (Energetex). 1981a. Burning of Crude Oil under Wind Herding Conditions. Report prepared for Canadian Marine Drilling Ltd.
- Energetex Engineering (Energetex). 1981c. In-Situ Combustion: an Oil Spill Countermeasure for Arctic Shorelines. Report for Environment Canada. Environment Canada, Ottawa, ON, Canada.
- Energetex Engineering (Energetex). 1982a. Improvement of Air-Deployable Oil Slick Igniters. Arctic Petroleum Operators Association (APOA) Project 165. APOA, Calgary, AB, Canada.
- Energetex Engineering (Energetex). 1982b. Environmental Testing of Dome Air-Deployable Igniter. Final Report prepared for Dome Petroleum Ltd., Calgary, AB, Canada, 28 p.
- Ewing, H. 1979. Devices to Contain Oil for In Situ Burning. *Spill Technology Newsletter*, May-June 1979, 4(3):175. Environment Canada, Ottawa, ON, Canada.
- Exxon. 1990. Valdez Oil Spill Technology. Exxon Production Research Company.

- Fingas, M.F., G. Halley, F. Ackerman, R. Nelson, M. Bissonnette, N. Laroche, P. Lambert, P. Jokuty, K. Li, N. Vanderkooy, W. Halley, G. Warbanski, P.R. Campagna, R.D. Turpin, M.J. Trespalacios, D.F. Dickins, E.J. Tennyson, D.V. Aurand, and R. Hiltbrand. 1994. The Newfoundland offshore burn experiment - NOBE, experimental design and overview. In: *Proceedings of the 17th Arctic and Marine Oilspill Program (AMOP) Technical Seminar*. Environment Canada, Ottawa, ON, Canada, p. 1053
- Franken, P., D. Perry, R. Randt, R. Petersen, and C. Thorpe. 1992. Combustive Management of Oil Spills - Final Report. University of Arizona, AZ, U.S.
- Freiberger, A. and J.M. Byers. 1971. Burning Agents for Oil Spill Cleanup. In: *Proceedings of the 1971 Conference on Prevention and Control of Oil Spills*, June 15-17, Washington, DC. American Petroleum Institute, Washington, DC, U.S., pp. 245-251.
- Frish, M., V. Gauthier, T. Frank, and P. Nebolsine. 1989. Laser Ignition of Oil Spills: Telescope Assembly and Testing. Environment Canada Report EE-I13, Environment Canada, Ottawa, ON, Canada.
- Frish, M., P. Nebolsine, M. DeFaccio, H. Scholaert, W. Kung, and J. Wong. 1986. Laser Ignition of Arctic Oil Spills - Engineering Design. In: *Proceedings of the Ninth Arctic and Marine Oilspill Program (AMOP) Technical Seminar*, June 10-12, Edmonton, AB. Environment Canada, Ottawa, ON, Canada, pp. 203-221.
- Garrett, W.D. and W.R. Barger. 1972. Control and Confinement of Oil Pollution on Water with Monomolecular Surface Films. Final Report to U.S. Coast Guard, Nov 1971, Project No. 724110.1/4.1. [also reprinted as U.S. Navy Naval Research Laboratory Memorandum Report 2451, June 1972, AD 744-943]. See also Garrett, W. and W. Barger. 1970. Factors affecting the use of monomolecular surface films to control oil pollution on water. *Environ. Sci. Technol.* 4(2) February 1970.
- Glaeser, J.L. and G.P. Vance. 1971. A Study of the Behaviour of Oil Spills in the Arctic. Report CG-D-53-74. U.S. Coast Guard Research & Development Center, Groton, CT, U.S., 60 p.
- Glosten Associates, Inc., D.F. Dickins Associates Ltd. (DF Dickins), and S.L. Ross Environmental Research Ltd. (SL Ross). 1991. Conceptual Design for a 144' X 60' X 11' Arctic Environment Incinerator Barge. Report to Shell Western E&P, Anchorage, AK, U.S.
- Guénette, C.C. and Sveum, P. 1995. Emulsion Breaking Igniters: Recent Developments in Oil Spill Igniter Concepts. In: *Proceedings of the 18th Arctic and Marine Oilspill Program (AMOP) Technical Seminar*, Vol. 2:1011-1025, Environment Canada, Ottawa, ON, Canada.
- Guénette, C.C., P. Sveum, C.M. Bech, and I.A. Buist. 1995. Studies of In Situ Burning of Emulsions in Norway. In: *Proceedings of the 1995 International Oil Spill Conference (IOSC)*, February 27 - March 2, Long Beach, CA. American Petroleum Institute, Washington, DC, U.S., pp. 115-122.
- Guénette, C.C. and R. Wighus. 1996. In situ burning of crude oil and emulsions in broken ice. In: *Proceedings of the 19th Arctic and Marine Oilspill Program (AMOP) Technical Seminar*, Vol. 2:895-906. Environment Canada, Ottawa, ON, Canada.
- Guénette, C.C. and J. Thornborough. 1997: An Assessment of Two Offshore Igniter Concepts. In: *Proceedings of the 20th Arctic and Marine Oilspill Program Technical Seminar*. Environment Canada, Ottawa, ON, Canada, p. 795.
- Haaktela, I. 1970. Oil spills off Finland. *Marine Pollution Bulletin*, 1(1):19-20.
- Hess, T.J., I. Byron, H.W. Finley, and C.B. Henry. 1997. The Rockefeller Refuge Oil Spill: a Team Approach to Incident Response. In: *Proceedings of the 1997 International Oil Spill Conference (IOSC)*. American Petroleum Institute, Washington, DC, U.S., 817 p.
- Horn S.A. and P. Neal. 1981. The *Atlantic Empress* Sinking - a Large Spill without Environmental Disaster. In: *Proceedings of the 1981 Oil Spill Conference*, March 2-5, Atlanta, GA. American Petroleum Institute, Washington, DC, U.S., pp. 429-435.
- Industry Task Group. 1983. Oil Spill response in the Arctic. Part 2. Field Demonstrations in broken Ice. Industry Task Force comprised of Shell Oil Company, Sohio Alaska Petroleum Company, Exxon Company, USA, and Amoco Production Company, Anchorage, AK, U.S.
- Jerbo, A. 1973. Two Types of Oil Spills in Swedish Inland Waters - Tests of new Materials, Ideas and Methods. In: *Proceedings of the 1973 Conference on Prevention and Control of Oil Spills*, March 13-15, Washington, DC. American Petroleum Institute, Washington, DC, U.S., 559 p.

- Kana, T.E., E. Thompson, and R. Pavia. 1981. *Burmah Agate: Chronology and Containment Operations*. In: *Proceedings of the 1981 Oil Spill Conference*, March 2-5, Atlanta, GA. American Petroleum Institute, Washington, DC, U.S., pp. 131-138.
- Koblanski, I.N. 1981. Oil Spill Removal in the Marine Environment Utilizing Acoustic Energy. *Journal of Canadian Petroleum Technology*, 20(3):92-96.
- Koblanski, I.N. 1983. An acoustical method of burning and collecting oil spills on cold open water surfaces. In: *Proceedings of the 1983 Oil Spill Conference*, February 28 -March 3, San Antonio, TX. American Petroleum Institute, Washington, DC, U.S., pp. 25-28.
- Koblanski, I.N. 1985. Design improvements in a sonic burner for the in-situ combustion of oil spills. In: *Proceedings of the 1985 Oil Spill Conference*, February 25-28, Los Angeles, CA. American Petroleum Institute, Washington, DC, U.S., p. 643.
- Laisk, E. 1976. Feasibility of Oil Slick Removal from Seawater using Power Lasers. *Environmental Science and Technology*, 10(8):814-815.
- Lane, P., P. Newsom, I.A. Buist, T.J. Nedwed, A. Tidwell, and K. Flagg. 2012. Recent Efforts to Develop and Commercialize Oil Herders. In: *Proceedings of the Thirty-fifth Arctic and Marine Oilspill Program (AMOP) Technical Seminar on Environmental Contamination and Response*, Environment Canada, Ottawa, ON, Canada.
- Lazes, R. 1994. A Study on the Effects of Oil Fires on Fire Boom Employed during the In Situ Burning of Oil. In: *Proceedings of the 17th Arctic and Marine Oilspill Program (AMOP) Technical Seminar*. Environment Canada, Ottawa, ON, Canada, p. 717.
- Lipski, C. 1986. Study of in-situ combustion of oil spills. Report to the Environmental Emergencies Technology Division, Environment Canada, Ottawa, ON, Canada, 24 p.
- Mabile, N. 2010. Fire Boom Performance Evaluation: Controlled Burning during the *Deepwater Horizon* Spill Operational Period. BP Americas. Houston, TX, U.S.
- Mabile, N. 2012. Controlled In Situ Burning: Transition from Alternative Technology to Conventional Spill Response Option. In: *Proceedings of the 33rd Arctic and Marine Oilspill Program (AMOP) Technical Seminar*. Environment Canada, Ottawa, ON, Canada, p. 584.
- Marine Research Associates. 1998. Technology Assessment and Concept Evaluation for Alternative Approaches to In Situ Burning of Oil Spills in the Marine Environment. Report to Minerals Management Service, Herndon, VA, U.S.
- Marine Spill Response Corporation (MSRC). 1995. Chemical Oil Spill Treating Agents. MSRC Technical Report Series 93-105, Marine Spill Response Corporation, Herndon, VA, U.S.
- May, V.L. and J.R. Wolfe. 1997. Field experience with controlled burning of inland oil spills. In: *Proceedings of the 1997 International Oil Spill Conference (IOSC)*, American Petroleum Institute, Washington, DC, U.S., 811 p.
- McAllister Engineering Ltd. 1979. Development and Testing of a "Quickie" Fire Resistant Oil Containment Boom. Report to Canadian Marine Drilling, Dome Petroleum Ltd., Calgary, AB, Canada.
- McAllister, I.R. and I.A. Buist. 1980. Fireproof boom development. Phase III -prototype construction and testing. Report for Dome Petroleum Ltd.
- McAllister, I.R. and I.A. Buist. 1981. Dome Petroleum's fireproof boom -development and testing to date. In: *Proceedings of the Fourth Arctic Marine Oilspill Program (AMOP) Technical Seminar*, June 16-18, Edmonton, AB. Environment Canada, Ottawa, ON, Canada.
- McCourt, J., I.A. Buist, B. Pratte, W. Jamieson, and J.V. Mullin. 1997. Testing Fire Resistant Boom in Waves and Flames. In *Proceedings of the 20th Arctic and Marine Oilspill Program (AMOP) Technical Seminar*. Environment Canada, Ottawa, ON, Canada, p. 823.
- McCourt, J., I.A. Buist, B. Pratte, W. Jamieson, and J.V. Mullin. 1998. Continued development of a test for fire booms in waves and flames. In: *Proceedings of the 21st Arctic and Marine Oilspill Program (AMOP) Technical Seminar*. Environment Canada, Ottawa, ON, Canada, p. 505.
- McCourt, J., I.A. Buist, W. Schmidt, D. Devitis, B. Urban, and J.V. Mullin. 1999. OHMSETT's Propane-Fuelled Test System for Fire-Resistant Boom. In: *Proceedings of the 22nd Arctic and Marine Oilspill Program (AMOP) Technical Seminar*. Environment Canada, Ottawa, ON, Canada, p. 439.

- McLeod, W.R. and D.L. McLeod. 1972. Measures to Combat Offshore Arctic Oil Spills. In *Proceedings of the Offshore Technology Conference*, Paper No. 1523 (2)14:141-162.
- McMinn, J. 1972. Crude Oil Behaviour on Arctic Winter Ice: Final Report. Office of R&D, U.S. Coast Guard, Project No. 734108. NTIS Publ. No. AT-754. Washington, DC, U.S.
- Meikle, K.M. 1981a. An Oil Slick Igniter for Remote Areas. In: *Proceedings of the 1981 Oil Spill Conference*, March 2-5, Atlanta, GA. American Petroleum Institute, Washington, DC, U.S.
- Meikle, K.M. 1981b. Incendiary Device for Oil Slick Ignition. In: *Proceedings of the Fourth Arctic and Marine Oilspill Program (AMOP) Technical Seminar*, June 16-18, Edmonton, AB. Environment Canada, Ottawa, ON, Canada, pp. 499-513.
- Meikle, K.M. 1983. An Effective Low-Cost Fireproof Boom. In: *Proceedings of the 1983 Oil Spill Conference*, February 28-March 3, San Antonio, TX. American Petroleum Institute, Washington, DC, U.S., pp. 39-42.
- Mitchell, J.B.A. 1990. The Effectiveness of Ferrocene in Reducing Smoke Emission from Burning Crude Oil. In: *Proceedings of the Thirteenth Arctic and Marine Oilspill Program (AMOP) Technical Seminar*, June 6-8, Edmonton, AB. Environment Canada, Ottawa, ON, Canada, pp. 75-85.
- Mitchell, J.B.A. and E. Janssen. 1991. The Use Of Additives For Smoke Reduction From Burning Pool Fires. In: *Proceedings of the Fourteenth Arctic and Marine Oilspill Program (AMOP) Technical Seminar*, June 12-14, Vancouver, BC. Environment Canada, Ottawa, ON, Canada, pp. 391-397.
- Mitchell, J.B.A. and M.E. Moir. 1992. Smoke Reduction from Pool Fires using Ferrocene and Derivatives. In: *Proceedings of the Fifteenth Arctic and Marine Oilspill Program (AMOP) Technical Seminar*, June 10-12. Edmonton, AB. Environment Canada, Ottawa, ON, Canada, pp. 681-689.
- Moffatt, C. and P. Hankins 1997. Results of Experiments with Flare Type Igniters on Diesel Fuel and Crude Oil Emulsions. In: *Proceedings of the 20th Arctic and Marine Oilspill Program (AMOP) Technical Seminar*. Environment Canada, Ottawa, ON, Canada, p. 1197.
- Moir, M.E., S. Charbonneau, and J.B.A. Mitchell. 1993. Soot Reduction Chemicals for In Situ Burning. In: *Proceedings of the 1993 Oil Spill Conference*, March 29-April 1. Tampa, FL. American Petroleum Institute, Washington, DC, U.S., pp. 761-764.
- NOBE Newsletter. September 1993. Environment Canada, Ottawa, ON, Canada.
- Nordvik, A., J. Simmons, J. Burkes, I.A. Buist, D. Blersch, and M. Reed. 1995. Mesoscale In Situ Burn Aeration Tests. MSRC Technical Report 95-017, Marine Spill Response Corporation, Washington, DC, U.S.
- OSIR (Oil Spill Intelligence Report). Published weekly by Cutter Information Corp., 37 Broadway. Arlington. MA 02174-5539, U.S.
- Pope, P., A.A. Allen, and W.G. Nelson. 1985. Assessment of Three Surface Collecting Agents during Temperate and Arctic Conditions. In: *Proceedings of the 1985 Oil Spill Conference*. API/EPA/USCG, Washington, DC, U.S., pp. 199-201.
- Potter, S. 2008. World Catalog of Oil Spill Response Products: Ninth Edition. SL Ross Environmental Research, Ltd. Ottawa, ON, Canada.
- Potter, S. and I.A. Buist. 2010. In Situ Burning in Arctic and Ice-Covered Waters: Tests of Fire-Resistant Boom in Low Concentrations of Drift Ice. In: *Proceedings of the 33rd Arctic and Marine Oilspill Program (AMOP) Technical Seminar*. Environment Canada, Ottawa, ON, Canada, p. 743.
- Preli, T.A., A.A. Allen, and D. Glenn. 2011. Development of High Speed Aerial Ignition Techniques For In Situ Burning. Paper delivered at the *Arctic Technology Conference during the Offshore Technology Conference*, February 7-9, 2011, Houston, TX, U.S.
- Purves, W. 1978. Design and Development of Equipment to Aid in the Burning of Oil On Water. In: *Proceedings of the First Arctic and Marine Oilspill Program (AMOP) Technical Seminar*, March 15-17, Edmonton, AB. Environment Canada, Ottawa, ON, Canada, p. 190.
- Purves, W.F. and A. Daoust. 1978. Booms for In Situ Burning of Oil Spills. Report to Environment Canada, Ottawa, ON, Canada.
- Raloff, J. 1993. Burning Issues: is Torching the Most Benign Way to Clear Oil Spilled at Sea? *Science News*, 144(14):220-223 (October 2, 1993).

- Ramsier, R.O., G.S. Gantcheff, and L. Colby. 1973. Oil spill at Deception Bay, Hudson Strait. Scientific Series No. 29, Inland Waters Directorate, Water Resources Branch, Environment Canada, Ottawa, ON, Canada.
- Rijkwaterstaat, 1974. Shell Herder Trials. Report to the Dutch Ministry of Transport, Gravenhage, Holland.
- Roberts, D. 1978. Development of Oil Spill Burning Equipment. In: *Proceedings of the First Arctic and Marine Oilspill Program (AMOP) Technical Seminar*, March 15-17. Edmonton, AB. Environment Canada, Ottawa, ON, Canada, pp. 191-193.
- Roberts, D. and D.K.T. Chu. 1978. Development of Oil Spill Burning Equipment. Report by Bennett Pollution Control to Environment Canada, Ottawa, ON, Canada.
- Robertson, I. 1991. Operational Examples of In Situ Burning: Lessons from the Burning of Two Recent Diesel Spills on the B.C. Coast. In: *Proceedings of the Fourteenth Arctic and Marine Oilspill Program (AMOP) Technical Seminar*, June 12-14, Vancouver, BC. Environment Canada, Ottawa, ON, Canada, pp. 411-419.
- Ross, S.L., C.W. Ross, F. Lepine, and K.E. Langtry. 1979. Ixtoc I Oil Blowout. *Environmental Protection Service Spill Technology Newsletter*, July-August. Environment Canada, Ottawa, ON, Canada.
- Ruby, C.H., L.G. Ward, I.A. Fischer, and P.J. Brown. 1978. Buzzards Bay Oil Spill - an Arctic Analogue. In: *Proceedings of the International Conference on Ports and Ocean Engineering under Arctic Conditions (POAC '77)*, 4th Conference, St. John's, NF, 1977
- S.L. Ross Environmental Research Ltd. (SL Ross) and DF Dickins Associates Ltd. (DF Dickins). 1987. Field Research Spills to Investigate the Physical and Chemical Fate of Oil in Pack Ice. Environmental Studies Revolving Funds Report No. 062, 95 p.
- S.L. Ross Environmental Research Ltd. (SL Ross). 1983. Evaluation of Industry's Oil Spill Countermeasures Capability in Broken Ice Conditions in the Alaskan Beaufort Sea. Report to Alaska Department of Environmental Conservation, Juneau, AK, U.S.
- S.L. Ross Environmental Research Ltd. (SL Ross). 1989. Disposal of Spilled Hibernia Crude Oils and Emulsions: In Situ Burning and the "Swirlfire" Burner. Report to Canadian Coast Guard, Ottawa, ON.
- SL Ross Environmental Research Ltd. (SL Ross). 1999. Re-engineering of a Stainless Steel Fire Boom for Use in Conjunction with Conventional Fire Booms. Final Report to Minerals Management Service, Herndon, VA, U.S.
- SL Ross Environmental Research, Ltd. (SL Ross). 2000. Data Report on U.S. Navy Fire Blanket Tests at OHMSETT. Report to PCCI, Alexandria, VA, U.S.
- SL Ross Environmental Research, Ltd. (SL Ross). 2002. Report on Fire Boom Tests at OHMSETT in October 2000. Final Report to Minerals Management Service, Herndon, VA, U.S.
- SL Ross Environmental Research Ltd. (SL Ross), DF Dickins Associates Ltd. (DF Dickins), and Alaska Clean Seas (ACS). 2003. Tests to Determine the Limits to In Situ Burning of Thin Oil Slicks in Broken Ice. Report to Minerals Management Service and ExxonMobil Upstream Research, Herndon, VA, U.S.
- S.L. Ross Environmental Research Ltd. (SL Ross). 2004. Preliminary Screening Tests of the Feasibility of Using Slurried Metallic Sodium as an Igniter for Thin Oil Slicks in Ice-Covered Waters. Report to ExxonMobil Upstream Research, Houston, TX, U.S.
- SL Ross Environmental Research, Ltd. (SL Ross). 2004a. Preliminary Research on Using Oil Herding Surfactant to Thicken Oil Slicks in Broken Ice Conditions. Report to ExxonMobil Upstream Research, Houston, TX, U.S., January 2004.
- SL Ross Environmental Research, Ltd. (SL Ross). 2005. Small-Scale Test Tank Research on Using Oil Herding Surfactants to Thicken Oil Slicks in Broken Ice for In Situ Burning. Report to ExxonMobil Upstream Research, Houston, TX, U.S.
- SL Ross Environmental Research, Ltd. (SL Ross). 2007. Mid-Scale Test Tank Research on using Oil Herding Surfactants to Thicken Oil Slicks in Broken Ice. Report to Minerals Management Service, ExxonMobil Upstream Research Company, Agip Kashagan North Caspian Operating Company, Sakhalin Energy Investment Company, and Statoil ASA, Herndon, VA, U.S.

- SL Ross Environmental Research, Ltd. (SL Ross). 2012a. Emulsion Breakers to Extend the Window-Of-Opportunity for Ignition and Burning In Fire Booms: Wave Tank Tests. Draft report to BP, Houston, TX, U.S.
- SL Ross Environmental Research, Ltd. (SL Ross). 2012b. Research on Using Oil Herding Agents for Rapid Response In Situ Burning of Oil Slicks on Open Water. Report to U.S. Department of Interior, Bureau of Safety and Environmental Enforcement, Herndon, VA, U.S.
- Salooja, K.C. 1972. Burner Fuel Additives. *Journal of the Institute of Fuel*, 45(371):37-42.
- Schrier, E. and C. Eidam. 1979. Cleanup Efficiency of a Fuel Oil Spill in Cold Weather. In: *Proceedings of the 1979 Oil Spill Conference*, March 19-22, Los Angeles, CA. American Petroleum Institute, Washington, DC, U.S., pp. 419-427.
- SINTEF and SL Ross Environmental Research, Ltd. (SL Ross). 1993. In Situ Burning of Water-In-Oil Emulsions. Draft Report to the Norwegian Clean Seas Association for Operating Companies (NOFO), Stavanger, Norway.
- Skinner, S.K. and W.K. Reilly. The Exxon Valdez Oil Spin - a Report to the President. The National Response Team, Washington, DC, U.S., 75 p.
- Smith, N.K. and A. Diaz. 1985. In-Place Burning of Crude Oil in Broken Ice -1985 Testing at OHMSETT. In: *Proceedings of the Eighth Arctic and Marine Oilspill Program (AMOP) Technical Seminar*, June 18-20, Edmonton, AB. Environment Canada, Ottawa, ON, Canada, pp. 176-191.
- Smith, N.K. and A. Diaz. 1987. In-Place Burning of Crude Oils in Broken Ice. In: *Proceedings of the 1987 Oil Spill Conference*, April 6-9, Baltimore, MD. American Petroleum Institute, Washington, DC, U.S., pp. 383-388.
- Solsberg, L. 1983. A Catalog of Oil Spill Containment Barriers. Environment Canada report EPS 9/SP/1. Environment Canada, Ottawa, ON, Canada.
- Solsberg, L. and R.C. Belore. 1982. An Operational Evaluation of the Prototype GEMENG Lightweight Fire Proof Boom. Report to Canadian Coast Guard and Environment Canada, Ottawa, ON, Canada.
- Stahovec, J.G., R.W. Urban, and K.V. Wheelock. 1999. Water-Cooled, Fire Boom Blanket, Test & Evaluation for System Prototype Development. In: *Proceedings of the 22nd Arctic and Marine Oilspill Program (AMOP) Technical Seminar*, Environment Canada, Ottawa, ON, Canada, 559 p.
- Summerfield, M. 1993. Radiative Exposure of Oil Spills on Seas or Rivers. In: *Proceedings of the 1993 Oil Spill Conference*, March 29-April 11, Tampa, FL. American Petroleum Institute, Washington, DC, U.S., 849 p.
- Swift, W.H., C.J. Touhill, and P.L. Peterson. 1968. Oil Spillage Control. *Chemical Engineering Progress Symposium Series*, 65(97):265-273.
- Tam, W.K. and W.F. Purves. 1980. Experimental Evaluation of Oil Spill Combustion Promoters. In: *Proceedings of the Oceans '80 International Forum on Ocean Engineering in the 80's*. IEEE, Piscataway, NJ, U.S., pp. 415-421.
- Thornborough, J. 1997. United Kingdom In Situ Burn Trials, Lowestoft, 1996. In: *Proceedings of the 1997 International Oil Spill Conference (IOSC)*. American Petroleum Institute, Washington, DC, U.S., 131 p.
- Twardawa, P. and G. Couture. 1983. Incendiary Devices for the In-Situ Combustion of Crude Oil Slicks. DND DREV report 4282/83. Environment Canada, Ottawa, ON, Canada.
- Twardus, E.M. 1978. Development and Evaluation of Continuously-Burning Wicking Devices for Burning Oil Slicks. In: *Proceedings of the First Arctic and Marine Oilspill Program (AMOP) Technical Seminar*, March 15-17, Edmonton, AB. Environment Canada, Ottawa, ON, Canada, pp. 164-178.
- Walavalkar, A.Y. and A.K. Kulkarni. 2001. Combustion of Mixtures of Weathered Alaskan Crude Oils and Water under External Heat Flux. In: *Proceedings of the Twenty-fourth Arctic and Marine Oilspill Program (AMOP) Technical Seminar*, Environment Canada, Ottawa, ON, Canada, pp. 755-765.

- Walton, W.D., W.H. Twilley, J.V. Mullin, and R.R. Hiltabrand. 1998. Evaluating a Protocol for Testing Fire-Resistant Oil Spill Containment Boom. In: *Proceedings of the 21st Arctic and Marine Oilspill Program (AMOP) Technical Seminar*. Environment Canada, Ottawa, ON, Canada, p. 651.
- Walton, W.D., W.H. Twilley, and J.V. Mullin. 1997. An Evaluation of Propane as a Fuel for Testing Fire-Resistant Oil Spill. In: *Proceedings of the 20th Arctic and Marine Oilspill Program (AMOP) Technical Seminar*. Environment Canada, Ottawa, ON, Canada, 755 p.
- Walton, W.D., W.H. Twilley, N.P. Bryner, L. DeLauter, R.R. Hiltabrand, and J.V. Mullin. 1999. Second Phase Evaluation of a Protocol for Testing Fire-Resistant Oil Spill Containment Boom. In: *Proceedings of the 22nd Arctic and Marine Oilspill Program (AMOP) Technical Seminar*. Environment Canada, Ottawa, ON, Canada, 447 p.
- Waterworth, M.D. 1987. The Laser Ignition Device and its Application to Oil Spills. In: *Proceedings of the 1987 Oil Spill Conference, April 6-9*, Baltimore, MD. American Petroleum Institute, Washington, DC, U.S., pp. 369-372.
- Whittaker, H. 1987. Laser Ignition of Oil Spills. In: *Proceedings of the 1987 Oil Spill Conference, April 6-9*, Baltimore, MD. American Petroleum Institute, Washington, DC, U.S., pp. 389-394.
- Williams, G.W., R. Gondek, A.A. Allen, and J. Michel. 2003. Use of In Situ Burning at a Diesel Spill in Wetlands and Salt Flats, Northern Utah, USA: Remediation Operations and 1.5 Years of Post-Burn Monitoring. In: *Proceedings of the 2003 International Oil Spill Conference (IOSC)*, American Petroleum Institute Publ. No. 14730 A (CD-ROM), Washington, DC, U.S.
- Williams, R.E. and T.S. Cooke. 1985. Feasibility of Using a Bubble Barrier for the Containment/Incineration of Spilled Oil. In: *Proceedings of the Eighth Arctic and Marine Oilspill Program (AMOP) Technical Seminar*, June 18-20, Edmonton, AB. Environment Canada, Ottawa, ON, Canada, pp. 212-227.

CHAPTER 7. ENVIRONMENTAL AND HUMAN-HEALTH EFFECTS OF UNBURNED OIL SPILLS

In situ burning removes surface oil by propelling much of it into the atmosphere in the form of combustion gases and soot. In this way in situ burning reduces the environmental threat posed by the oil slick, but only at the cost of increasing the environmental threat posed by the airborne plume. In both the burned and unburned cases, a weathered residue is left on the surface to pollute water-surface resources and shorelines. However, the amount of residual oil is much greater without burning and is considerably less weathered, especially considering that most spills of crude emulsify quickly and increase in bulk several-fold if not burned or dispersed beforehand. Decision makers need to compare the effects of burning versus not-burning and choose the option that provides the greater net benefit to the environment.

The fate and effects of oil spills have been extensively reviewed in the past, including: Clarke & MacLeod (1977); Duval (1985); Jordan & Payne (1980); Lee (1980); Mackay (1984); NRC (1985); Owens & Trudel (1985); SL Ross (1985); and SL Ross (1993). New knowledge about spill fate and impact has been gained from research on spills including: *Exxon Valdez* (U.S. in 1989); *Haven* (Italy in 1991), *Braer* (U.K. in 1992); *Sea Empress* (U.K. in 1997), *Prestige* (France and Spain in 2002), and *Deepwater Horizon* (U.S. in 2010). Early research into the fate and effects of spills in Arctic and ice-covered waters was reviewed by Duval *et al.* (1985) and more recently in work by SL Ross *et al.* (2010). The following text is based on these reviews.

7.1 Fate and Movements of Oil Spills

The nature and magnitude of impact of an oil spill are determined by several factors including:

1. The location of the spill and where the oil is directed by winds and currents;
2. The persistence and spreading of the spilled oil; and
3. The distribution of oil sensitive resources (birds, mammals, fisheries) and their sensitivity (toxicity) to oil.

At least 1 and 2 (above) are influenced by the presence of ice.

When persistent oil is spilled on open water from either a tanker or an oil well platform blowout the spilled oil spreads, forming a thin slick on the sea surface. Spreading is initially rapid, but then slows as, over a period of days, the slick breaks up into smaller and smaller patches and ultimately dissipates as tar balls. For a time after the spill, the oil slick poses a risk to marine wildlife and fisheries. The threat persists as long as oil concentrations on the sea surface are high enough to deliver an effective dose of oil to sensitive things encountering it. However, after a time, concentrations of oil on the sea surface are not sufficient to do damage. While oil is spreading, it is moved by winds and currents and can travel downwind and down current for tens or hundreds of kilometres, impacting wildlife and fisheries in its path for as long as surface oil concentrations are high enough to do damage. The size of the area impacted is a function of the amount of oil spilled and its persistence. The location of the impact is determined by the location of the spill and direction in which the spill is moved by local winds and currents.

In many spills that occur near shore some of the spilled oil will encounter shoreline and become stranded in the intertidal zone, exposing and potentially impacting biota or human-use features present. The fate of the oil on shorelines depends on the shore substrate (rock, gravel, sand marsh) and degree of wave-exposure. On more exposed shores, oil may be re-suspended by

waves and tides and redistributed along the shore or be sedimented into the nearshore subtidal areas. On porous and protected shores oil may penetrate becoming a source of chronic contamination for years or decades after the spill.

As soon as spilled oil forms a slick the lighter, more volatile components begin to evaporate and are quickly lost within a matter of one or two days. Depending on the type of oil, this might correspond to a loss of 10 to 40% of the volume of oil spilled. At the same time a small proportion of the volume of the slick is lost through the dissolution and physical dispersion of oil into the water under the slick. Usually only a very small proportion of the spill volume is lost by dispersion. Reductions on the volume of oil in the slick through both of these processes produce a net reduction in the size of the area impacted by the spill.

While part of the slick is being lost by evaporation and dispersion, the slick is also absorbing water droplets forming a water-in-oil emulsion. This is important because emulsification has the effect of: a) increasing the apparent volume of the slick; and b) making the slick more viscous and persistent. The quicker the spill emulsifies the more persistent it becomes and the larger is its area of impact.

Although it is not very likely to occur, oil from spills can reach the seabed in two ways. As mentioned above, oil that has been stranded on a shoreline can be resuspended by waves and tides and deposited in shallow subtidal areas as happened on a large scale in the *Braer* (U.K. in 1993) spill. In offshore areas, oil that is dispersed as tiny droplets into the water under slicks spreads by diffusion and is degraded by indigenous bacteria that agglomerate on the droplets. With time these agglomerations can sink slowly to the seabed and become mixed into seabed sediments.

Some spills originate at the sea surface (e.g., *Exxon Valdez*, Alaska in 1989), while others originate from the seabed, for example, from oil well drilling accidents (e.g., *Ixtoc 1* spill off Mexico in 1979; *DWH*, U.S. in 2010). During subsea spills the oil may be discharged into the water near the seabed in the form of a jet of oil and gas. The jet shears the oil into small droplets that then rise quickly to the sea surface near the spill site where they form a slick. As the droplets rise through the water column a portion of the more soluble components in the oil are lost to the surrounding water. Once the oil reaches the surface the fate, movement and impact of the slicks are similar to those of surface slicks. The actual distribution, average thickness and therefore potential recovery or combustion of the slicks depend upon the nature and amount of oil released, the water depth and the wind/sea conditions at the time of the spill.

7.1.1 *Effects of Presence of Ice on Oil Fate*

Exploration or production activities in ice-affected oceans may result in spills into open water, but they can also result in oil being discharged onto or under ice, or onto the sea among broken ice. The presence of ice will greatly alter the behaviour and movement of the oil and its environmental impact. Early work on the fate of oil in ice was reviewed in Duval (1985); more recent work was summarized in SL Ross *et al.* (2010). Subsea blowouts can result in large amounts of oil under ice. Based on SL Ross *et al.* (2010), effects of ice on the fate, behaviour and movements of oil spills include the following;

- a) **Spreading** - Ice cover prevents or slows spreading regardless of whether the oil is on ice, under it or in the water among ice flows.
- b) **Evaporation** - Cold temperatures slow the rate of evaporation of spills slightly; however, the effects of ice containing oil and keeping slicks thick over extended periods of time can

significantly reduce evaporation. Oil encapsulated in ice will not evaporate significantly until the ice melts and releases the oil.

- c) **Emulsification** - The presence of ice dampens wave action so that oil contained in broken ice emulsifies more slowly than on open water. Oil spilled near the edge of pack ice exposed to wave action from open water (the marginal ice zone) can be subjected to additional mixing energy caused by the repetitive collisions of adjacent ice floes and grinding action of the floes, which can induce emulsification (and natural dispersion).

Unlike spills in open water where oil movement is controlled by winds and currents, the movement of spilled oil that is on or under ice or contained in broken ice will move with (or in close proximity to) the ice.

7.2 Environmental Effects

This is a brief summary of the potential effects of oil spills on living environmental resources and the exposure conditions causing these effects. The following are discussed in turn:

1. Effects of oil slicks and oil stranded on shorelines;
2. Effects of dispersed oil in the water column and of sedimented oil; and,
3. Effects of the airborne plume of hydrocarbon vapour.

7.2.1 Oil Slicks and Oil Stranded on Shores

The most visible effects of oil spills are those caused by oil slicks at sea and oil stranded on shorelines. Slicks and stranded oil cause a variety of effects on natural resources and human-use environmental resources.

Oil slicks on the sea impact species that inhabit the sea surface or dive through the sea surface. These include marine birds, waders and marine mammals. Oil affects these animals either by physically disrupting the waterproofing of their plumage or pelage or through chemical toxicity to the organism if the oil is ingested while preening or is inhaled. Effects are dose-dependent, although exposure or dosage may be difficult to quantify in some circumstances, and exposure thresholds may be difficult to determine precisely. For marine birds, the risk of exposure to oil slicks varies with habits, with species that sit on the sea surface or dive through it being more vulnerable to oiling than those that spend much of their time soaring over the sea. For marine mammals sensitivity to oiling varies with dependency on pelage for insulation. Species that rely heavily on hair for insulation (e.g., sea otter, polar bear) are highly sensitive to oil, while those that rely on a thick layer of blubber for insulation and have little hair (e.g., cetaceans) are relatively insensitive to oiling. Species like pinnipeds (seals and sea lions) that use both hair and blubber have intermediate sensitivity. As discussed above, the degree of effects of any spill depend on spill location, size, environmental conditions (winds), oil persistence and the sensitivity and vulnerability of local resource populations.

In addition, oil slicks or oil contamination of the water column, seabed and the tissues of fishery species pose a significant risk to human activities, such as commercial fishing and aquaculture. Oil slicks and contamination of the water column and seabed disrupt fishing activities by oiling gear. When fish habitat becomes contaminated by spilled oil and target fishery species themselves become contaminated, fisheries may be closed until it can be demonstrated that levels of contamination in catches have returned to safe levels. Criteria for "acceptability" are the presence of "off-flavours" and elevated levels of polynuclear aromatic hydrocarbons (PAH)

in edible tissues, particularly chemical species that have been linked to cancers (e.g., benzo(a)pyrene.)

Oil slicks on the open sea generally dissipate over a time periods of days or weeks, depending on the nature of the release, the type and amount of oil spilled, and the weather conditions. Recovery rates for resources affected by oil spills vary widely. Most seabird or marine mammal populations require several years to recover from significant spill damage; heavily impacted populations may require many years to recover because their reproductive rates are low. Studies conducted following the *Exxon Valdez* spill (U.S. in 1989), showed that recovery times for most spill damaged populations were consistent with the known reproductive rates for the species. On the other hand, detailed studies of impacted fish, bird and mammals showed that recovery of certain populations (e.g., sea otters, waterfowl, finfish) were delayed by many years. In some cases delayed recovery could be linked to persistent habitat contamination by the spilled oil, but in other cases the cause of the delays remains unknown (*Exxon Valdez* Oil Spill Trustees Council, 2012). For some species (finfish, crustaceans), disruptions of fisheries by spills are relatively short-lived (months), lasting only until environmental oil contamination has dissipated and regulators have demonstrated that spill-related tissue contamination of fish has returned to acceptable levels. However, elevated tissue contamination can persist in some species for years (particularly clams and oysters) and in these cases fisheries have remained closed for several years.

Oil that becomes stranded on shorelines may have important and long-lasting effects on the natural biological communities and on the human-use potential of these shorelines. Biological resources may be affected by chemical toxicity or smothering. Oil affects the biological communities of all different shoreline types, but perhaps the most noteworthy effects are those involving vegetated shorelines such as marshes or mangroves. Spill effects are important here because the marshes and mangroves provide cover, substrate, and energy for the biological communities that depend on them and, as a result, damage to plants may indirectly result in significant damage to other constituents of these communities. In addition, roots of shoreline vegetation provide stabilization of shoreline sediments, and loss of the plants and their root systems may lead to erosion of the shorelines and thus lead to longer-term consequences of spills. Effects on marsh plants and mangroves are dose dependent: light oiling may do limited damage causing only short-lived, sublethal effects, but heavy oiling or oiling with light oil with high aromatic content may cause death to mangrove trees and marsh plants and have long-lasting effects (years).

As with oil slicks at sea, effects of stranded oil depend on the level of oiling, the properties of the oil arriving at shorelines and the sensitivity of the shorelines. Persistence of the oil depends on the degree of exposure of the shore to wave action, oil type and the type of shoreline substrate. Recovery time for shoreline environments after the spilled oil has been removed may vary from months to many years depending on the nature of the community affected and the level of damage.

In ice-affected waters, risks of shoreline contamination to vegetation is perhaps less critical than in temperate or tropical climates because there are no mangroves and generally few coastal marshes. In the Arctic, most shorelines are composed of rock, gravel, cobble or slumping tundra. Perhaps of the greater concern regarding shoreline contamination in the Arctic is the potential for stranded oil to be remobilized to: a) contaminate nearshore subtidal benthic areas

occupied by nearshore fish populations or b) contaminate nearshore waters utilized by concentrations of marine birds or waterfowl during migrations or moulting.

7.2.2 Oil on Ice, Under Ice, or Among Broken Ice

A number of small spills onto or among ice have been documented in recent years (Christensen, 2008; Kennicutt *et al.*, 1991; Lampela, 2007; Rivet, 2000), but effects of these spills on ice-associated biota have not been documented. Early experimental work measured toxic effects (96-hr LC₅₀ of mechanically dispersed oil on ice-associated biota - arctic marine amphipods, an arctic marine copepod and one arctic marine fish – Foy, 1979) and this work has been summarized in Martin (1985) and Wells & Percy (1985).

7.2.3 Offshore Water Column and Seabed Effects

As described earlier, some oil from a slick becomes dispersed or dissolved in the water column under the slick. Some of this entrained oil may ultimately associate with particulate matter and settle through the water column to the seabed. Despite the vast number of laboratory studies that have found toxic effects of dispersed oil or oil-contaminated sediments, significant kills of fishes and other pelagic or benthic species have rarely been found at actual spills, even extremely large ones. Similarly, extensive contamination of seabed sediments and damage to offshore seabed communities are uncommon phenomena during spills.

Although rare, extensive fish kills have nevertheless been observed during some oil spills. Fish kills or wide-spread sublethal effects have been observed in spills that have caused high levels of hydrocarbons in the upper water column, such as very large spills or spills of lighter, higher-aromatic-content oil occurring in shallow or confined near shore waters. For example a near shore spill of a large quantity of No. 2 fuel oil in the *North Cape* spill (Michel *et al.*, 1997) or *Barge Florida* spill (Saunders *et al.*, 1972), and a similar spill involving a mixture of fuels including aviation fuel (Gooding, 1971) all resulted in extensive fish mortality. In most spills, however, major fish kills are not observed.

In offshore waters or open coastal waters under average wind conditions (8 to 15-knots), oil generally disperses into the water column only, slowly. This fact coupled with the fact that dispersed oil diffuses horizontally and vertically very quickly means that oil concentrations even in the upper 1-m of the water column under an oil slick seldom exceed several hundred parts per billion or a few parts of total oil per million parts of water. This concentration is below the toxic threshold for most significant acute effects on marine organisms. Thus, the threat to fish and other pelagic species from entrained oil is minor in most cases. In the unlikely event that fish populations were damaged because of exposure to high levels of hydrocarbons, recovery might require only a few years or less because the reproductive potential of fish is high.

Extensive seabed contamination with extensive evidence of sublethal effects and contamination of finfish and shellfish has generally been encountered only when oil is spilled into or is moved into shallow, nearshore areas (e.g., *Amoco Cadiz* France in 1979, *Exxon Valdez*, U.S. in 1989, *Braer* U.K. in 1993). In general, the risks to benthic communities from oil settling to the seabed in offshore areas are limited because:

1. Oil is entrained into the seabed only very slowly;
2. Only a small portion of the entrained oil becomes associated with large particles that will actually sink; and

3. Sinking rates of suspended particles are very slow relative to the rates of spreading and diffusion.

As a result, although some spilled oil may ultimately reach the seabed through sedimentation, offshore spills are unlikely to result in extensive contamination of the seabed to a level (concentration) necessary to cause effects to benthic infauna and epifauna. When seabed sediments do indeed become heavily contaminated with hydrocarbons from spilled oil, contamination can be persistent, with some hydrocarbons persisting in measurable amounts in sediments for several years. However, once hydrocarbon concentrations return to background levels, benthic communities appear to recover as quickly as pelagic communities.

7.2.4 Airborne Oil and Hydrocarbons

As mentioned above, a considerable proportion of spilled hydrocarbons can be lost from a slick into the atmosphere through evaporation. Evaporating hydrocarbons form an invisible plume originating over the slick and setting downwind. However, no record exists of significant environmental effects having been caused by plumes of hydrocarbon vapours.

7.3 Human Health and Safety

There has been some concern in recent years about the human health implications of marine oil spills. This concern is founded in part on the known toxicity of hydrocarbons to humans (NRC, 1985) and in part on reports of symptoms of acute hydrocarbon poisoning among individuals in the vicinity of spills. The present section summarizes the human health aspects of major oil spills as well as the safety aspects.

7.3.1 Oil Slicks and Oil Stranded on Shorelines

Oil slicks and oil stranded on shorelines pose a threat to human health through the potential for fire and through chemical toxicity resulting from dermal contact with oil. The risk of accidental fire is significant only in spills of lighter oils during the early stages of the spill while the oil is thick and fresh and will support combustion. The adverse effects of dermal contact with oil are well known; for example, in small-animal studies prolonged dermal exposure to crude and refined products has resulted in dermal irritation, but with certain oils has led to dermal necrosis and systemic effects (NRC, 1985). Response workers have reported skin effects from dermal contact; for example, during the *Amoco Cadiz* spill, response workers reported skin irritation resulting from direct skin contact with oil (Menez *et al.*, 1978). However, there have been no reports of systemic toxic effects or skin necrosis among spill response workers that can be attributed to skin contact with oil.

In view of the obviously limited risk to spill workers from direct dermal contact with oil, it is reasonable to assume that local residents would be at even less risk of toxic effects resulting from incidental contact with oil at sea or on shorelines.

7.3.2 Dissolved/Dispersed and Sedimented Oil

As discussed above, oil that becomes entrained into the water column may occur in the form of dissolved hydrocarbons, dispersed oil droplets, or oil-contaminated seabed sediments. Humans might be exposed to this oil via two routes. Oil might be ingested directly if the contaminated waters are used for human consumption. More commonly, oil poses a threat if the

contaminated waters support stocks of fish, shellfish, or aquatic plants that are exploited for human consumption.

The threat to drinking water supplies is of concern in spills into fresh waters or in marine spills when seawater intakes for desalination plants are threatened (e.g., Ecopetrol pipeline spill, Colombia: Anonymous, 1993). In either case, the potential for significant exposure to humans is difficult to assess since in most cases the threatened waters are processed prior to consumption. Threats are generally short-lived except in the case of very large spills, with extensive shoreline contamination such as the 1991 Arabian Gulf spill.

The contamination of exploited fish stocks with spilled hydrocarbons has been common in the past (Tidmarsh *et al.*, 1986). Fish and shellfish may become contaminated via water-borne hydrocarbons or through hydrocarbon-contaminated seabed sediments. Aquatic organisms accumulate a broad spectrum of hydrocarbons and, although all hydrocarbons have potential health implications, the group of particular concern historically has been the polynuclear aromatic hydrocarbons (PAHs) some of which have been shown to be carcinogenic (e.g., benzo[a]pyrene) (NRCC, 1983).

Contamination of edible tissues of finfish and shellfish is a common consequence of spills. Contamination of offshore pelagic species by water-borne hydrocarbons appears to be far less important than that of benthic species contaminated via sediments in shallow, nearshore environments because the former phenomenon would be very short-lived, while the latter may persist for months or years, as long as significant levels of contaminants persist in the sediments. Contamination of certain invertebrates, such as bivalve molluscs, is regarded as being of greater significance than that of finfish because finfish are capable of rapidly metabolizing accumulated PAHs while bivalves lack this capability.

For the DWH oil spill in 2010, the FDA, U.S. EPA, CDC/ATSDR, NOAA and Gulf state representatives developed health-based criteria to evaluate PAH levels in seafood (White, 2011). **Table 7-1** lists these levels of concern.

Table 7-1: Health-based criteria for PAHs in seafood (from White, 2011)

Chemical	Surface Water Screening Levels (µg/L)	Levels of Concern (µg/mg)		
		Shrimp and Crab	Oysters	Finfish
Naphthalene	NA 5	123	133	32.7
Fluorene	220	246	267	65.3
Anthracene/Phenanthrene	1660	1846	2000	490
Pyrene	166	185	200	49
Fluoranthene	26	246	267	65.3
Chrysene	0.00076	132	143	35
Benzo[k]fluoranthene	0.00076	13.2	14.3	3.5
Benzo[b]fluoranthene	0.00076	1.32	1.43	0.35
Benzo[a]anthracene	0.00076	1.32	1.43	0.35
Indeno[1,2,3-cd]pyrene	0.00076	1.32	1.43	0.35
Dibenzo[ah]anthracene	0.00076	0.132	0.143	0.035
Benzo[a]pyrene	0.00076	0.132	0.143	0.035

Benzene	0.44	17.5	18.9	4.6
Ethylbenzene	106	615	667	163
Toluene	260	492	533	130
Xylene	NA	1230	1333	327
Petroleum Aliphatics C ₁₀ -C ₃₆	NA	615	667	163

7.3.3 Airborne Hydrocarbon Plume

In recent years concerns have been expressed about the potential human health effects of airborne plumes of hydrocarbons generated by oil spills. Plumes are most commonly composed of hydrocarbon vapours, but under unique circumstances they may also contain concentrations of airborne oil droplets. Workers or local residents would be exposed to these airborne hydrocarbons primarily via inhalation or ingestion. In the scientific literature, there are some studies of health effects caused by hydrocarbon vapour clouds generated by spills. One partially documented case of possible petroleum intoxication is described in the literature involving the *Amoco Cadiz* spill. During the course of the spill, cleanup workers and local residents exhibited symptoms characteristic of hydrocarbon poisoning. Victims suffered prolonged exposure to clouds of hydrocarbon vapour that enveloped the coast of Brittany, as well as to clouds of airborne oil droplets caused by high-pressure water washing of oiled shorelines. Some victims exhibited gross symptoms of hydrocarbon poisoning including dizziness, nausea, and abdominal pains, but clinical tests suggested that none had suffered systemic effects (Menez *et al.*, 1978, cited in NRC, 1985). Regrettably, there does not appear to be any systematically gathered data concerning the hydrocarbon exposure conditions of these workers or residents during this spill.

During the *Braer* spill in the Shetland Islands in January, 1993, there was sufficient concern among the regional medical community for the health of the local inhabitants that a number of local residents were examined for indications of hydrocarbon toxicity. The results of these tests have yet to be published (Campbell, 1993; Christie, 1993).

Additional information can be found in a study of the *Nakhodka* oil spill. On January 2, 1997, the Russian tanker *Nakhodka* broke up in the Sea of Japan and spilled more than 6100-tonnes of oil. The majority of the oil spill hit the western coastline of Honshu. Because machines could not access the area, workers and residents used buckets and ladles to clean up the oil.

Morita *et al.* (1999) examined exposures and health effects in local residents involved in clean-up of the shore. Air monitoring conducted on January 10 found low levels of hydrocarbons. The highest detected concentration was 1.51 ppm on January 15. Otherwise the highest total hydrocarbon levels were < 1 ppm and the daily averages were < 0.5 ppm. H₂S was not detectable with instruments able to detect as low 0.0001-ppm. The highest concentration of suspended particles on any given day was 0.88 mg/m³, which is below the occupational standard of 2 mg/m³. The concentrations of oil mist were measured in two or three areas every day from January 10 and were lower than 0.005 mg/m³. Four individuals involved in the cleanup wore personal monitors for 2-hours on January 31, which were tested for benzene, toluene, and xylene. All measurements were < 9 ppb; the highest benzene, toluene, and xylene readings were 1.85, 8.34, and 1.43-ppb, respectively.

A total of 282 residents who participated in the cleanup were interviewed between January 20 to 31 to identify associated symptoms. The average time spent working on cleanup was 4 to 5-days. Ninety-seven of these residents had urine samples collected and tested for hippuric acid (a metabolite of toluene), methylhippuric acid (a metabolite of xylene), and trans-trans-muconic acid (a metabolite of benzene). The date of collection for the urine samples was unclear. Residents had direct exposure to oil on their hands and face. Oil was removed using soap and water or unidentified chemical agents.

The main health complaints were low back or leg pain (37%); eye symptoms (29%); headache (20%); throat symptoms (18%); and skin symptoms (12%). A total of 56.7% of men reported at least one symptom compared with 78.7% of women reporting at least one symptom. The urine samples showed three individuals with a hippuric acid level > 1.0 g/L, which was normal at a second examination in May 1997.

The authors noted that it was "inconceivable" that the physical symptoms were caused by a direct toxicological effect from the oil since analysis of the released oil showed only a few volatile components and the air monitoring showed low levels. They also noted that other sources of exposure could have accounted for the slightly higher hippuric acid level in the three individuals.

Despite symptoms consistent with exposure to the components of oil, VOC levels in the air were very low. In addition, urine testing results also did not identify significant exposures to VOCs, although it is difficult to fully interpret the results since information regarding when they were collected was not presented. As with any interview survey, the potential for recall bias was present.

Lyons *et al.* (1999) performed a retrospective cohort study of residents living near the *Sea Empress* oil spill. On February 15, 1996, the *Sea Empress* released approximately 73,000-tonnes of light crude oil and 366-tonnes of heavy fuel oil when it ran aground at the entrance of Milford Haven harbour in Wales. Approximately 200-km of coastline was contaminated. The oil was reported to first come ashore in one area on February 17 and in a different area on February 22.

Individuals living in four coast towns (exposed) and those living in two towns on the opposite coast (unexposed) were mailed a questionnaire seven weeks after the incident with a retrospective health diary covering the four weeks immediately after the incident. The survey response rate was 68% in the exposed group (539/796) and 70% in the control group (550/789). The four-week period prevalence of almost all symptoms were significantly higher in the exposed group (i.e., generally ill, headache, nausea, diarrhea, sore eyes, runny nose, sore throat, cough, itching skin, rash, shortness of breath, weakness, and anxiety). The exposed group was noted to report more anxiety and depression with an increased anxiety score being associated with an increased prevalence of symptoms. A total of 112 of the exposed group (23.3%) believed the oil spill had affected their health.

The authors concluded that there was an increase in self-reported psychological and physical symptoms in the exposed population. Of note was the finding that some individuals were excluded from the analyses because they reported substantially higher rates of illness on February 16, before the spill had even come ashore or significant amounts of oil had leaked and was attributed to "biased recall." The authors noted that before the excess of symptoms can be attributed to exposure to the oil spill, possible biases from recall and rumination bias leading to exaggeration of symptoms in the exposed populations should be considered.

However, they concluded that after “conservative allowances are made for bias, the physical health of the exposed group remained significantly worse than the controls.” They noted that information on individual exposures would have strengthened this conclusion. Potential explanations for the increased symptom reporting included perceived exposure to an environmental threat. However, they noted that the increase in headaches, sore eyes, and sore throat after day one was consistent with exposure to crude oil and detergents and were similar to those reported after the *Braer* spill. Although they noted a possibility that psychological effects were secondary to a toxic effect of the oil, they noted it was probable that much, if not all, of the psychological effect was a generalized reaction to environmental disasters.

As noted by the authors, interpretation of the study results is severely limited by the absence of any exposure information for the participants. No air monitoring data was presented. No information was provided on the distance of the four “exposed” towns from the spill or the activities of the participants. There was no information regarding the number of individuals who may have participated in clean-up activities on the coast. There was no information provided regarding the composition of the released petroleum products or their potential to have significant volatilization several days or more after being released from the ship. No information was provided regarding the detergents used, although it was suggested that the reported health effects were consistent with exposure to these products. Due to the absence of any exposure assessment, it is impossible to reliably attribute the symptom reports to inhalation exposures from the released oil.

Several studies have evaluated residents and workers associated with the *Prestige* oil spill. On November 13, 2002, the oil tanker *Prestige*, which was carrying 78,200-tonnes of Bunker C Oil (also known as fuel oil Number 6), was damaged. Six days later, the ship broke in two and sank to a depth of 3500-m approximately 200-km off the coast of Spain. Over the following months, 68,000-tonnes of the oil were estimated to have been released from the ship and contaminated more than 1000-km of coast. Oil was first seen on the Spanish coast by November 16, 2002. Published health studies related to the spill examined acute health effects (Suarez *et al.*, 2005); influence of protective devices on health (Carrasco *et al.*, 2006); and persistent respiratory symptoms (Zock *et al.*, 2007).

Suarez *et al.* (2005) examined acute health effects reported by individuals involved in clean-up of the Asturias and Cantabria area of Spain. These areas were noted to be northwest of the coastal area where oil was first observed after the incident. Oil in these areas was not seen until December 6 (i.e., more than 3 weeks after the incident). The study population included 400 individuals from each of the two regions with an equal distribution between the types of workers (i.e., salaried workers, volunteers, seamen, and bird cleaners). The sample was weighted towards those who cleaned for longer periods. Data were obtained through a computer-assisted telephone interview. Data were collected on injuries and “toxic effects” which included headaches, eye symptoms, throat and respiratory symptoms, and neurovegetative symptoms such as dizziness, nausea, and vomiting. The authors noted that all these symptoms had previously been related to VOC and/or PAH exposure.

Overall, seamen reported the highest prevalence of symptoms with the most frequent being sore throat, respiratory problems and headaches. Conditions which were associated with “toxic effects” included working for longer than 20-days in highly polluted areas, performing three or more activities, having skin contact with fuel on the head/neck or upper limbs, eating while in contact with fuel, or perceiving disturbing odors. Cleaning boulders, rocks, beaches, and

wharves was associated with headaches, itchy eyes and neurovegetative disorders. Receiving health and hygiene information prior to working appeared to be a protective factor.

The authors noted that skin irritation was scarcely reported and a low proportion of cleaners experienced acute health problems. The authors suggested that seamen had more health problems possibly due to higher exposures to VOC at sea. Limitations noted by the authors included the use of self-reported data and an absence of objective data on environmental exposures or biomarkers. The temporal relationship between symptoms and exposure also could not be assessed.

Carrasco *et al.* (2006) examined the association between acute health symptoms and the provision of health information in clean-up workers using the same population sample as Suarez *et al.* (2005). Most participants received health protection information in the form of an oral briefing prior to the start of the activity. Uninformed subjects were significantly more likely to report itchy eyes (Odds Ratio [OR] 2.67), nausea/vomiting/dizziness (OR 2.09), and throat and respiratory problems (OR 2.08). The health protection briefing was also associated with greater use of protective devices such as protective goggles, gloves, boots, and mask.

Zock *et al.* (2007) examined the prevalence of upper and lower respiratory symptoms among 4281 fisherman who participated in clean-up activities and compared them with 2499 fisherman who were not involved in clean-up. Symptoms prevalence was assessed using a questionnaire through self-administration or telephone interview. Participants were asked yes/no questions for various symptoms and the period which they worked. The data were obtained 14 to 27-months after the spill occurred. The reported response rate for the survey was 76%. Participants were involved in clean-up activities anywhere from 1 to 576-days with an average of 38.2. Number of hours per day ranged from 0.5 to 24 with an average of 6.2. The overall OR for any lower respiratory tract symptom (i.e., wheeze with breathlessness, wheeze apart from colds, nocturnal attacks of shortness of breath, chronic cough and/or chronic phlegm) was significantly elevated at 1.73. The OR's when stratified by area were 1.26, 1.83, and 1.76 for less, moderately, and most affected areas, respectively. A clear dose-response relationship was not evident based on area worked. OR's based on number of days of participation ranged from 1.26 for 1 to 3-days of participation to 1.89 for 35 or more days of participation. Based on hours worked per day, the OR was 1.35 for < 4-hours per day to 2.12 for 8 or more hours per day. OR's increased with number of clean-up activities from 1.37 for one activity to 2.35 for five or more activities. The odds ratio for use of a face mask often or always was 1.39 compared with 2.05 for those who never used a face mask or used it only sometimes. OR's based on time elapsed between participation in clean-up activities and lower respiratory symptoms were 2.33, 1.69, and 1.24 for an elapsed time of approximately 12 months, 18 months, and 2 years, respectively.

The authors concluded that "participation in clean-up activities of oil spills may result in prolonged respiratory symptoms lasting 1 to 2 years after exposure. They further recommended that all involved individuals with recurrent exposure to oil should be subjected to medical surveillance to detect potential long term effects. Specific medical monitoring methods were not described. The authors acknowledged that alternative explanations for the reported symptoms may include "medically unexplained physical symptoms", or MUPS, which may occur for several years after various types of disasters. Limitations regarding the use of self-reported data, possible recall bias, and non-response bias were also noted.

The biggest weakness of this study is the lack of exposure assessment. No exposure monitoring data was reported for the participants, although it was noted that personal measurements in volunteers who gathered oil from the beaches had a mean total VOC concentration of 0.5 mg/m³. No analysis was provided as to dose-response relationships associated with VOC exposure. No analysis was provided regarding the specific composition of either fresh product from the ship or weathered oil which was found on-shore and the potential VOC air concentrations which might occur from either.

Janjua *et al.* (2006) published a study of the acute health effects of residents near the *Tasman Spirit* oil spill on water near Karachi, Pakistan in 2003. On August 13 and 14, the Greek tanker *Tasman Spirit* broke apart and released Iranian light crude oil into the sea. After this initial release, there were two more releases of oil from the tanker, with the last on August 29. The total amount spilled was more than 35,500-tonnes of crude oil. The oil was 14% light naphtha, 20% heavy naphtha, 4% gasoline, and 1.35% sulfur by weight.

Strong waves and winds carried the oil and VOCs to the populated shore. On August 20, VOCs on shore ranged from 44-ppm to 179-ppm. Ten days later, the VOC levels had decreased to 8 to 10-ppm. Air levels for specific volatiles, such as benzene or toluene, were not reported. The smell of oil was still detectable on shore until September 5.

The health survey started on September 1. Residents living on the shore line reported an increased frequency of sore eyes, sore throat, headache, breathing difficulties, nausea and vomiting compared with people living 2-km and 20-km inland. However, only 33% of the exposed group sought medical attention for their symptoms, and 66% of those who did seek care reported only one visit. Sixty-seven percent of those in the exposed group experiencing symptoms stated that they had recovered completely or were recovering. This would indicate that in most cases symptoms were mild and transient.

Meo *et al.* (2009) examined health effects in workers involved in clean-up of the *Tasman Spirit* spill. The study was conducted between July 2003 and December 2004. A total of 115 workers involved in clean-up who worked at least 8 to 10-hours a day for six days a week were interviewed by the study investigator. The workers were noted to wear a simple, cloth-made nose and mouth mask as a protective measure. Of these 50 individuals described as healthy males were admitted to the study group and compared with a control group composed of individuals who lived 15 to 20-km from the coastal belt. The clean-up group had a significantly higher level of general illness, cough, sore throat, runny nose, eye irritation, nausea, and headache. Rates of shortness of breath, wheezing, chest tightness, asthma attacks, itchy skin, fever, vomiting, diarrhea, and abdominal pain were also higher in the exposed group but not statistically significant. The authors concluded that "*air pollution due to crude oil spillage into sea water may cause respiratory and general health complaints in workers involved in oil cleanup operations.*" They noted that most of the health effects are due to the physicochemical properties of the crude oil, the magnitude of spillage, and the nature of the tasks involved. Witness to such catastrophes may also lead to psychological disorders. Interpretation of the study results is limited since no exposure assessment information was reported for the workers.

In the DWH spill in the Gulf of Mexico in 2010, Middlebrook *et al.* (2012) reported concentrations of selected VOCs in the airborne plume in the DWH region. These data are discussed in detail in **Chapter 8**.

The effects of acute and chronic exposure to hydrocarbon vapours by inhalation have long been recognized. Experimental studies have established that relatively brief exposures (30 to 60-minutes) to gasoline vapours produce eye, nose and throat irritation at concentrations of 500 to 1000-ppm; headache and numbness at slightly higher concentrations; and deep anaesthesia at 10,000-ppm (Poklis & Burkett, 1977). Regulatory standards have been established for short-term and chronic exposure to hydrocarbon vapours and mists in the workplace. For example, the ACGIH Short Term Exposure Limit (STEL) for gasoline vapours is 500-ppm for 15-minute exposures and the Threshold Limit Value-Time Weighted Average (TLV-TWA) is 300 ppm for an 8-hr exposure.

For communities and the general public, Acute Exposure Guideline Levels (AEGs), Emergency Response Planning Guide (ERPG) levels, and Temporary Emergency Exposure Limits (TEELs) have been established to protect human health. AEGs were developed for high-priority, acutely toxic chemicals by the National Research Council at the request of the EPA and ATSDR. The term AEGs is used to reflect the broad application of these values to planning, response and prevention in the community, the workplace, transportation, the military, and the remediation of Superfund sites (NRC, 2001). The American Industrial Hygiene Association (AIHA) developed ERPGs for emergency planning and the values are intended as health-based guideline concentrations for single exposures to chemicals (AIHA, 2006). The Department of Energy, Subcommittee on Consequence Assessment and Protective Action (DOE/SCAPA, 2012) has developed TEELs for emergency planners performing hazard assessment for chemicals without ERPGs. TEELs are intended for use until AEGs or ERPGs are adopted for the specific chemicals.

Tables 7-2 through **7-5** lists occupational and community health-based standards and guidelines for selected components of oil.

Compound	ACGIH TLV-TWA	ACGIH STEL
Mineral oil, pure, highly and severely	5 mg/m ³	No standard
Gasoline	890 mg/m ³ (300 ppm)	1480 mg/m ³ (500 ppm)
Asphalt (petroleum fumes)	5 mg/m ³	No standard

Table 7-3: Workplace Exposure Standards for selected components of oil							
Analyte	CAS Number	Occupational Exposure Values*					
		ACGIH TLVs	units	OSHA PELs	Units	NIOSH RELs	Units
Benzene	71-43-2	0.5	ppm	1	ppm	0.1	ppm
Toluene	108-88-3	20	ppm	200	ppm	100	ppm
Ethylbenzene	100-41-4	20	ppm	100	ppm	100	ppm
m-Xylene*	108-36-3	100	ppm	100	ppm	100	ppm
p-Xylene*	106-42-3	100	ppm	100	ppm	100	ppm
o-Xylene*	95-47-6	100	ppm	100	ppm	100	ppm
Naphthalene	91-20-3	10	ppm	10	ppm	10	ppm
n-Hexane	110-54-3	50	ppm	500	ppm	50	ppm
Cyclohexane	110-82-7	100	ppm	300	ppm	300	ppm
Butane	106-97-8	800	ppm	NE	NE	800	ppm

*Xylene screening values are for mixed xylene screening guidelines

- NE = Not Established
- ACGIH TLV-TWA - Threshold Limit Value – Time Weighted Average (TLV-TWA). The TWA concentration for a conventional 8 – hour work day and a 40 – hour workweek, to which it is believed that nearly all workers may be repeatedly exposed, day after day, without adverse effect (ACGIH, 2012).
- ACGIH TLV-Ceiling-Threshold Limit Value – Ceiling (TLV-C). The concentration that should not be exceeded during any part of the working exposure. If instantaneous measurements are not available, sampling should be conducted for the minimum period of time sufficient to detect exposures at or above the ceiling value (ACGIH 2012).
- OSHA PEL-TWA - Permissible Exposure Limit – Time Weighted Average (PEL-TWA). Permissible concentration in air of a substance that shall not be exceeded in any 8 – hour work shift of a 40 – hour work week. (OSHA 29 CFR: 1910.1000).
- OSHA PEL-Ceiling - Permissible Exposure Limit – Ceiling (PEL-C). The exposure limit that shall at no time be exceeded. If instantaneous monitoring is not feasible, then the ceiling shall be assessed as a 15 – minute time weighted average exposure, which shall not be exceeded at any time during the working day (OSHA 29 CFR: 1910.1000).
- NIOSH RELs - Time-weighted average (TWA) concentrations for up to a 10-hour workday during a 40-hour workweek (NIOSH, 2005).
- NIOSH RELs-Ceiling - The ceiling value should not be exceeded at any time (NIOSH, 2005).

Table 7-4: AEGL and ERPG Values for potential components of volatilized oil									
Analyte	CAS Number	AEGLs 60 min				ERPGs			
		AEGL 1	AEGL 2	AEGL 3	Units	ERPG-1	ERPG-2	ERPG-3	Units
Benzene	71-43-2	52	800	4,000**	ppm	50	150	1,000	ppm
Toluene	108-88-3	200	1,200**	4,500**	ppm	50	300	1,000	ppm
Ethylbenzene	100-41-4	33	1,100	1,800	ppm	NE	NE	NE	
m-Xylene*	108-36-3	130	920**	2,500**	ppm	NE	NE	NE	
p-Xylene*	106-42-3	130	920**	2,500**	ppm	NE	NE	NE	
o-Xylene*	95-47-6	130	920**	2,500**	ppm	NE	NE	NE	
Naphthalene	91-20-3	NE	NE	NE		NE	NE	NE	
n-Hexane	110-54-3	NR	3,300**	8,600¶	ppm	NE	NE	NE	
Cyclohexane	110-82-7	NE	NE	NE		NE	NE	NE	
Butane	106-97-8	5,500**	17,000¥	53,000¥	ppm	NE	NE	NE	

- NE = Not Established
- NR = Not recommended due to insufficient data
- *Xylene screening values are for mixed xylene screening guidelines
- **value is ≥ 10% lower explosive limit (LEL)
- ¶ = the value is higher than 50% of the LEL of hexane in air (LEL = 1.1 % or 11,000 ppm)
- ¥ = the value is greater than 50% of the LEL of butane in air (LEL is 19,000 ppm)
- AEGL-1 is the airborne concentration of a substance above which it is predicted that the general population, including susceptible individuals, could experience notable discomfort, irritation, or certain asymptomatic, non-sensory effects. However, these effects are not disabling and are transient and reversible upon cessation of exposure (U.S. EPA, 2012).
- AEGL -2 is the airborne concentration of a substance above which it is predicted that the general population, including susceptible individuals, could experience irreversible or other serious, long-lasting, adverse health effects or an impaired ability to escape (U.S. EPA, 2012).
- AEGL -3 is the airborne concentration of a substance above which it is predicted that the general population, including susceptible individuals, could experience life-threatening adverse health effects or death (U.S. EPA, 2012).
- ERPG-1 = The maximum concentration in air below which it is believed nearly all individuals could be exposed for up to 1 hr. without experiencing other than mild transient adverse health effects or perceiving a clearly defined objectionable odor (AIHA, 2012).
- ERPG-2 = The maximum concentration in air below which it is believed nearly all individuals could be exposed for up to 1 hr. without experiencing or developing irreversible or other serious health effects or symptoms that could impair their abilities to take protective action (AIHA, 2012).
- ERPG-3 = The maximum concentration in air below which it is believed nearly all individuals could be exposed for up to 1 hr. without experiencing or developing life-threatening health effects (AIHA, 2012).

Table 7-5: TEEL values for potential components of volatilized oil					
Analyte	CAS Number	TEEL-1	TEEL-2	TEEL-3	Units
Acenaphthene	83-32-9	3.6	40	240	mg/m ³
Acenaphthylene	208-96-8	10	110	660	mg/m ³

Analyte	CAS Number	TEEL-1	TEEL-2	TEEL-3	Units
Anthracene	120-12-7	0.27	3	530	mg/m ³
Benzo(g,h,i)	191-24-2	30	330	2000	mg/m ³
Fluorene	86-73-7	6.6	72	430	mg/m ³
Phenanthrene	85-01-8	0.76	8.3	360	mg/m ³
Pyrene	129-00-0	0.15	1.7	7.5	mg/m ³
Naphthalene	91-20-3	15	15	500	ppm
n-Hexane	110-54-3	300			ppm
Cyclohexane	110-82-7	100	100	10000	ppm

- TEEL-1 = the airborne concentration (expressed as ppm or mg/m³) of a substance above which it is predicted that the general population, including susceptible individuals, when exposed for more than one-hour, could experience notable discomfort, irritation, or certain asymptomatic, nonsensory effects. However, these effects are not disabling and are transient and reversible upon cessation of exposure (DOE/SCAPA, 2012).
- TEEL-2 = the airborne concentration (expressed as ppm or mg/m³) of a substance above which it is predicted that the general population, including susceptible individuals, when exposed for more than one-hour, could experience irreversible or other serious, long-lasting, adverse health effects or an impaired ability to escape (DOE/SCAPA, 2012).
- TEEL-3 = the airborne concentration (expressed as ppm or mg/m³) of a substance above which it is predicted that the general population, including susceptible individuals, when exposed for more than one-hour, could experience life-threatening adverse health effects or death (DOE/SCAPA, 2012).

For recent spills, there has been some documentation of the atmospheric hydrocarbon concentrations at the site and at near-by residential areas. These levels are discussed further in **Chapter 8**.

In short, the toxic potential of petroleum hydrocarbon vapours is well-recognized. Toxic thresholds have been determined and industrial exposure standards have been established for vapours from a variety of petroleum hydrocarbon products. There are indications from accounts of actual spills that acute petroleum intoxication from airborne plumes may have occurred during historical spills. Unfortunately, there are few data available from these cases concerning concentrations of hydrocarbon vapours in the atmosphere over or around actual oil slicks.

7.4 Summary

Spills appear to pose a greater risk to living environmental resources than to human health and safety. The levels of effects vary greatly from spill to spill depending on the volume and type of oil spilled and the circumstances of the spill. However, given a moderate-sized batch spill of medium crude oil in coastal zone waters under average summer weather conditions for the continental U.S., the following generalities hold for environmental effects of spills:

1. Untreated oil spills pose a threat to organisms that inhabit the sea surface, intertidal zone, and to a lesser extent the seabed and water column in shallow near shore waters. Spills also pose a risk to human activities, such as fishing, that depend on resource in these areas.
2. The greatest environmental damage results from the contact of wildlife (birds and mammals) by oil slicks and of habitat resources (marshes, mangroves) by oil stranded on shorelines.
3. Oil that becomes entrained into the water column poses only a moderate threat to natural resources because, in general, concentrations of oil in the water column are low and very short-lived. On the other hand, significant mortalities to fish have been reported under unique circumstances in which large volumes of lighter oils have been spilled in shallow, near shore areas or in confined areas with limited dilution potential.
4. Contamination of seabed sediments with the associated risks to benthic resources is rare in offshore spills, but in cases involving large, near shore spills such as the *Amoco Cadiz*, significant levels of benthic contamination have resulted. In the *Amoco Cadiz* case, extensive contamination and biological damage did occur to populations of living benthic resources that persisted for months to years.
5. Assessing the potential impact of ice on the fate and impact of spills appears to be somewhat complex. For oil spilled onto or under ice the presence of ice may actually minimise the size of the area impacted by preventing the oil from spreading and thereby possibly facilitating cleanup. On the other hand, oil spilled on or under ice will not spread and dissipate but will be contained in high concentrations for months or years posing a long-term threat to ice-associated populations like seals polar bears and epontic fauna.
6. There is no recorded evidence of significant environmental effects caused by airborne plumes of volatile gases generated by oil slicks. However, under unique circumstances, oil has been transported in the form of droplets (aerosols) and deposited on or ingested by terrestrial wildlife and domestic livestock.

Although the toxic potential of oil and petroleum hydrocarbons to humans is well documented, there are very few documented cases in which significant human health or safety problems have resulted from spills. That said, it is worth noting that oil releases do pose a significant accidental ignition risk near their source. During spills, the groups at greatest risk from the spilled oil include the cleanup workers and the local residents. Their health risks from the spills are as follows:

1. Under all but exceptional circumstances, oil slicks or oil stranded on shorelines pose little health/safety risk except when the oil poses a significant fire risk within the first few hours immediately following the spill.
2. Historical evidence suggests that humans can suffer adverse effects from exposure to the airborne plumes of hydrocarbon vapours generated by oil slicks. Both cleanup workers and local residents might be at some risk of sublethal effects (nausea, dizziness) from the airborne plume of volatile gases (and in certain circumstances airborne oil droplets) generated by a large slick, or a vapour cloud caused by high pressure water or steam jets used to clean oil from shorelines.
3. The oil that becomes entrained into the water column probably poses little threat to human health. However, in larger near shore spills appreciable amounts of oil may accumulate in the sediments where they in turn pose a threat to contaminate exploited fishing resources for months or years following a spill. These may pose a health risk to humans ingesting the

fishery products, but these risks are difficult to evaluate due to the lack of health standards for ingestion of hydrocarbon-contaminated food products.

References to Chapter 7

- American Conference of Governmental Industrial Hygienists (ACGIH). 2012. 2012 TLVs and BEIs: Based on the Documentation of the Threshold Limit values for Chemical Substances and Physical Agents and Biological Exposure Indices. American Conference of Governmental Industrial Hygienists: Cincinnati, OH, U.S.
- American Industrial Hygiene Association (AIHA). 2006. Emergency Response Planning Guidelines (ERPG) Committee Procedures and Responsibilities. American Industrial Hygiene Association, Fairfax, VA, U.S.
- American Industrial Hygiene Association (AIHA). 2012. 2012 Emergency Response Planning Guidelines (ERPG) and Workplace Environmental Exposure Level (WEEL) Handbook. American Industrial Hygiene Association, Fairfax, VA, U.S.
- Anonymous. 1993. Columbian Spill Threatens Water Supply. *Oil Spill Intelligence Report*, XVI (34), 4 p.
- Campbell, N.M. 1993. Shetland Oil Spill. *Br. Med. J.*, 306:519.
- Carrasco, J.M., V. Lope, B. Perez-Gomez, N. Aragones, B. Suarez, G. Lopez-Abente, F. Rodriguez-Artalejo, and M. Pollan. 2006. Association between Health Information, use of Protective Devices and Occurrence of Acute Health Problems in the *Prestige* Oil Spill Clean-Up in Asturias and Cantabria (Spain): A Cross-Sectional Study. *BMC Public Health*, 6:1.
- Christensen, K. 2008. Observations of Fuel Transport on Sea Ice from Two Fuel Release Events with Relevance to Site Assessment and Closure. *Cold Regions Science and Technology*, 53:92-101.
- Christie, B. 1993. Shetland Oil Spill Prompts Health Checks on Islanders. *Br. Med. J.*, 306:230.
- Clark, R.C. and W.D. MacLeod. 1977. Impacts, Transport Mechanisms and Observed Concentration of Petroleum in the Marine Environment. In: D.C. Malins (Ed.). *Effects of Petroleum on Arctic and Subarctic Marine Environments and Organisms. Vol. 1. Nature and Fate of Petroleum*. Academic Press, Inc. New York, NY, U.S., pp. 91-223.
- DOE/SCAPA. 2012. Protective Action Criteria (PAC): Chemicals with AEGLs, ERPGs & TEELs: Rev. 27. U.S. Department of Energy, Washington, DC, U.S. <http://www.atlant.com/DOE/teels/teel.html>.
- Duval, W.S. (Ed.). 1985. A Review of the Biological Fate and Effects of Oil in Cold Marine Environments. Report EE74, Environment Canada, Edmonton, AB, Canada, 242 p.
- Exxon Valdez Oil Spill Trustees Council. 2012. Status of Injured Resources & Services, (see <http://www.evostc.state.ak.us/recovery/status.cfm>).
- Foy, M.G. 1979. Acute Lethal Toxicity of Prudhoe Bay Crude Oil and Corexit 9527 to Arctic Marine Invertebrates and Fish from Frobisher Bay, N.W.T. Unpubl. Rept. by LGL Ltd., for Environmental Protection Service, Hull. U.K. 90 p.
- Gooding, R.M. 1971. Oil Pollution on Wake Island from the Tanker *R.C. Stoner*. Special Scientific Report – Fisheries No. 636. NOAA / National Marine Fisheries Service, Seattle, WA, U.S., 12 p.
- Janjua, N.Z., P.M. Kasi, H. Nawaz, S.Z. Farooqui, U.B. Khuwaja, Najam-ul-Hassan, S.N. Jafri, S.A. Lutfi, M.M. Kadir, and N. Sathiakumar. 2006. Acute Health Effects of the *Tasman Spirit* Oil Spill on Residents of Karachi, Pakistan. *BMC Public Health*, 6:84.
- Jordan, RE. and J.R. Payne. 1980. Fate and Weathering of Petroleum Spills in the Marine Environment. Ann Arbor Science Publ, Ann Arbor, MI, U.S.
- Kennicutt, M.C., S.T. Sweet, W.R. Fraser, M. Culver, and W.L. Stockton. 1991. The Fate of Diesel Fuel Spilled by the *Bahia Paraiso* in Arthur Harbor, Antarctica. In: *Proceedings of the 1991 Oil Spill Conference*, March, 1991. American Petroleum Institute, Washington, DC, U.S., pp. 493-500.
- Lee, R.F. 1980. Processes Affecting the Fate of Oil in the Sea. In R.A. Geyer (Ed), *Marine Environmental Pollution - 1 Hydrocarbons*. Elsevier, New York, NY, U.S., pp.337-351.

- Lampela, K. 2007. Baltic Approach to Oil Spill Recovery in Ice: Case Studies and Recent Development in Baltic Sea States. In: *Proceedings of the 2007 International Oil & Ice Workshop*. Minerals Management Service, Herndon, VA, U.S.
- Lyons, R.A., J.M. Temple, D. Evans, D.L. Fone, and S.R. Palmer. 1999. Acute Health Effects of the Sea Empress Oil Spill. *J Epidemiol Community Health*, 53(5):306-310.
- Mackay, D. 1984. The Fate and Behaviour of Oil in Cold Climates. Report to Environment Canada, Department of Chemical Engineering and Applied Chemistry. Environment Canada, Ottawa, ON, Canada.
- Martin, L. 1985. Epontic Fauna. In: W.S. Duval (Ed.), *A review of the biological fate and effects of oil in cold marine environments*. Report EE74, Environment Canada, Edmonton, AB, Canada, 242 p.
- Menez, IR., F. Berthou, D. Picart, and C. Richie. 1978. Impacts of the Oil Spill (*Amoco Cadiz*) on Human Biology. *Penn. Ar. Bed.*, 94:367-378.
- Meo, S. A., A.M. Al-Drees, S. Rasheed, I.M. Meo, M.M. Al-Saadi, H.A. Ghani, and J.R. Alkandari. 2009. Health Complaints among Subjects Involved in Oil Cleanup Operations during Oil Spillage from a Greek Tanker "*Tasman Spirit*". *Int J Occup Med Environ Health.*, 22(2):143-8.
- Michel, J., F. Czulak, D. French, and M. Sperduto. 1997. Natural Resource Impacts from the North Cape Oil Spill. In: *Proceedings of the 1997 International Oil Spill Conference (IOSC)*, April, 1997. American Petroleum Institute, Washington, DC, U.S., pp. 841-850.
- Middlebrook, A.M., D.M. Murphy, R. Ahmadov, E.L. Atlas, R. Bahreini, D.R. Blake, J. Brioude, J.A. de Gouw, F.C. Fehsenfeld, G.J. Frost, J.S. Holloway, D.A. Lack, J.M. Langridge, R.A. Lueb, S.A. McKeen, J.F. Meagher, S. Meinardi, J.A. Neuman, J.B. Nowak, D.D. Parrish, J. Peischl, A.E. Perring, I.B. Pollack, J.M. Roberts, T.B. Ryerson, J.P. Schwarz, J.R. Spackman, C. Warneke, and A.R. Ravishankara. 2012. Air Quality Implications of the Deepwater Horizon Oil Spill. *Proc Natl Acad Sci U.S.A.* 2012, Jan 5.
- Morita, A., Y. Kusaka, Y. Deguchi, A. Moriuchi, Y. Nakanaga, M. Iki, S. Miyazaki, and K. Kawahara. 1999. Acute Health Problems among the People Engaged in the Cleanup of the *Nakhodka* Oil Spill. *Environ Res.*, 81(3):185-94.
- National Research Council (NRC). 1985. *Oil in The Sea: Impacts, Fate and Effects*. National Academy Press, Washington, DC, U.S., 601 pp.
- National Research Council (NRC). 2001. *Standing Operating Procedures for Developing Acute Exposure Guideline Levels for Hazardous Chemicals*. Subcommittee on Acute Exposure Guideline Levels, NRC, Washington, DC, U.S.: National Academy Press.
- National Research Council of Canada (NRCC). 1983. *Polynuclear Aromatic Hydrocarbons in the Aquatic Environment: Formation, Sources Fate and Effects on Aquatic Biota*. Associate Committee on Scientific Criteria for Environmental Quality, NRCC No. 18981, National Research Council of Canada, Ottawa, ON, Canada.
- National Institute for Occupational Safety and Health (NIOSH). 2005. *NIOSH Pocket Guide to Chemical Hazards*. DHHS (NIOSH) Publication No.2005-149. National Institute for Occupational Safety and Health; Cincinnati, OH, U.S.
- Occupational Safety and Health Administration (OSHA). *Air Contaminant--Permissible Exposure Limits*. 29CFR1910.1000
- Owens, E.H. and K. Trudel. 1985. *Oil Spill Countermeasures for Low-Energy Shorelines In Canada*. Report EE-73. Environment Canada, Ottawa, ON, Canada.
- Poklis, A. and C.D. Burkett. 1977. Gasoline Sniffing: A Review. *Clinical Toxicol.* 11(1):35-41.
- Rivet, C. 2000. *Oil in Ice: The St. Lawrence Experience*. In: *Proceedings of the 2000 International Oil & Ice Workshop*, Alaska Clean Seas, Prudhoe Bay, AK, U.S.
- SL Ross Environmental Research Ltd. (SL Ross). 1985. *An Overview of Physical and Chemical Processes in Open Water*. In W.S. Duval (Ed). *A review of the biological fate and effects of oil in cold marine environments*. Unpubl. Rep. by ESL Environmental Sciences limited, S.L. Ross Environmental Research Ltd., and Arctic Laboratories Limited for Canada, Environmental Protection Service, Edmonton, AB, Canada, pp. 5-12.

- Saunders, H.L., I.F. Orassle, and O.R. Hampson. 1972. The West Falmouth Oil Spill. I. Biology. *Tech Rep. Woods Hole Oceanogr. Inst.* (72-80): 48 pp.
- S.L. Ross Environmental Research Ltd. (SL Ross). 1993. The Risk of Tainting in Flatfish Stocks during Offshore Oil Spills. Environment Studies Research Funds Report No. 121. Calgary, AB, Canada, 48 pp.
- SL Ross Environmental Research Ltd. (SL Ross), DF Dickins Associates LLC. (DF Dickins), Envision Planning Solutions, Inc. 2010. Beaufort Sea Oil Spills State of Knowledge Review and Identification of Key Issues. Environment Studies Research Funds Report No. 177. Calgary, AB, Canada, 126 p.
- Suarez, B., V. Lope, B. Perez-Gomez, N. Aragones, F. Rodriguez-Artalejo, F. Marques, A. Guzman, L.J. Vilorio, J.M. Carrasco, J.M. Martin-Moreno, G. Lopez-Abente, and M. Pollan. 2005. Acute Health Problems among Subjects Involved in the Cleanup Operation Following the *Prestige* Oil Spill in Asturias and Cantabria (Spain). *Environ Res.*, 99(3):413-424.
- Tidmarsh, W.G., R. Ernst, R. Aclanan, and T. Farquharson. 1986. Tainting of Fishery Resources. Environment Studies Research Funds, Canada; Issue 21 of Environmental Studies Revolving funds Report. 194 p.
- U.S. Environmental Protection Agency (U.S. EPA). 2012. Acute Exposure Guideline Levels. U.S. Environmental Protection Agency, Washington, DC, U.S. (<http://www.epa.gov/oppt/aegl/>).
- Wells, P.G. and J.A. Percy. 1985. The Effects of Oil on Arctic Invertebrates. In: F. Engelhardt (Ed.), *Petroleum Effects In The Arctic Environment*, Elsevier, London, pp. 101-156.
- White, L. 2011. Deepwater Horizon Study Group Working Paper: Human Health. University of California at Berkeley, Center for Catastrophic Risk Management, Berkeley, CA, U.S., (http://ccrm.berkeley.edu/pdfs_papers/DHSGWorkingPapersFeb16-2011/HumanHealth-LAW_DHSG-Jan2011.pdf).
- Zock, J.P., G. Rodriguez-Trigo, F. Pozo-Rodriguez, J.A. Barbera, L. Bouso, Y. Torralba, J.M. Anto, F.P. Gomez, C. Fuster, and H. Vereá. 2007. Prolonged Respiratory Symptoms in Clean-Up Workers of the *Prestige* Oil Spill. Center for Research in Environmental Epidemiology, Municipal Institute of Medical Research, Barcelona, Spain. *Am. J. Respir. Crit. Care Med.*, Sept. 15; 176(6):610-6.

CHAPTER 8. REVIEW OF ENVIRONMENTAL AND HUMAN-HEALTH EFFECTS OF IN SITU BURNING

8.1 Introduction

This chapter summarizes the documented ecological and human health effects of combustion products and residues from the burning of marine oil spills. Risks from burning are determined by the composition of the burn products and their environmental fates and effects. In this chapter:

- a) **Section 8.3** deals with composition, fate and environmental effects of burn products and residues;
- b) **Section 8.4** deals with human health effects.

The information is used in the risk analysis that follows (**Chapter 9**) to identify the advantages and drawbacks of burning spilled oil.

8.2 Methods

8.2.1 Technical Subjects

Understanding the environmental and human health effects of in situ burning of oil spills on water and ice was approached from the following perspectives:

- Effects of the combustion itself on the environment;
- Fate and effects of burn residues and products in the aquatic environment, whether at the water surface, in the water column or on the seabed (in the case of sinking residues);
- Fate and effects of the smoke or emissions plumes on air quality; and
- Ultimate fate and effects of airborne particles (soot).

8.2.2 Information Sources and Approach

In 1994, Buist *et al.* exhaustively reviewed this subject documenting the environmental fate of burn products, potential human and environmental exposures to burn emissions and products and the possible toxic and health risks from these exposures. The work documented existing knowledge and identified gaps. In the 18-years since that review, further research has been accomplished and burning was used in a major way to respond to at least one major spill, the DWH in Gulf of Mexico in 2010. In this work, knowledge gained over the 18-years has been used to revise and expand the 1994 report and fill some gaps identified in that work.

8.3 Behaviour, Fate and Environmental Effects of Burn Products and Residue

Risks posed to ecological resources and to human health from burning oil on water are directly related to the composition, behaviour, and fate of the burn products. This section reviews the state of knowledge concerning these subjects. The effects of spill burning are discussed in a later section (**Section 8.4**). In situ burning of oil spills on water results in burn products reaching the air, water, seabed sediments, and land (**Figure 8-1**). The most obvious risk vectors for environmental effects from spill-related oil fires are:

- a) The fire itself and the burning slick on the water column and risk of burn residue remaining on the sea surface for some time or sinking to the seabed;
- b) The fire and burn residue on vegetated shorelines; and
- c) Emissions of airborne burn product into the atmosphere, with contaminants largely converted from a liquid to an airborne plume composed of gases and particulates (soot), with the soot eventually settling in the aquatic environment or on soils.

These three environmental sectors (water, air, and sediments) are discussed below.

8.3.1 *Aquatic*

Burning oil slicks in or on ice or oil collected in a boom changes the fate of the hydrocarbons and potential effects of the spill in several ways:

- Burning reduces the volume of oil present dramatically and quickly;
- The oil remaining after the fire (residue) differs markedly in composition, physical properties and toxicity from the parent oil. Residue may or may not sink to the seabed, depending on initial oil properties and composition; and,
- The fire itself may impact the upper water column by heating it or altering the dissolution or dispersion of some oil.

8.3.1.1 *Burn Residue*

Burning operations during the DWH spill produced a floating residue that was stiff and tarry-like when it cooled (Allen, 2011). Our knowledge of the properties and risk factors associated with residue are as follows.

8.3.1.1.1 *Burn Efficiency.*

As detailed in **Chapter 4**, burning greatly and quickly reduces the volume of oil present. A range of factors influence ignitability and burn efficiency and the volume of residue produced. As long as the oil is ignitable, burn efficiency is a function of three main factors: initial slick thickness; thickness of residue at the extinction of the burn; and aerial coverage of the flame. **Chapter 4** shows that burn efficiency is strongly influenced by slick thickness. Slicks that have been thickened by booming may burn with up to 99% efficiency depending on the composition of the oil and state of emulsification.

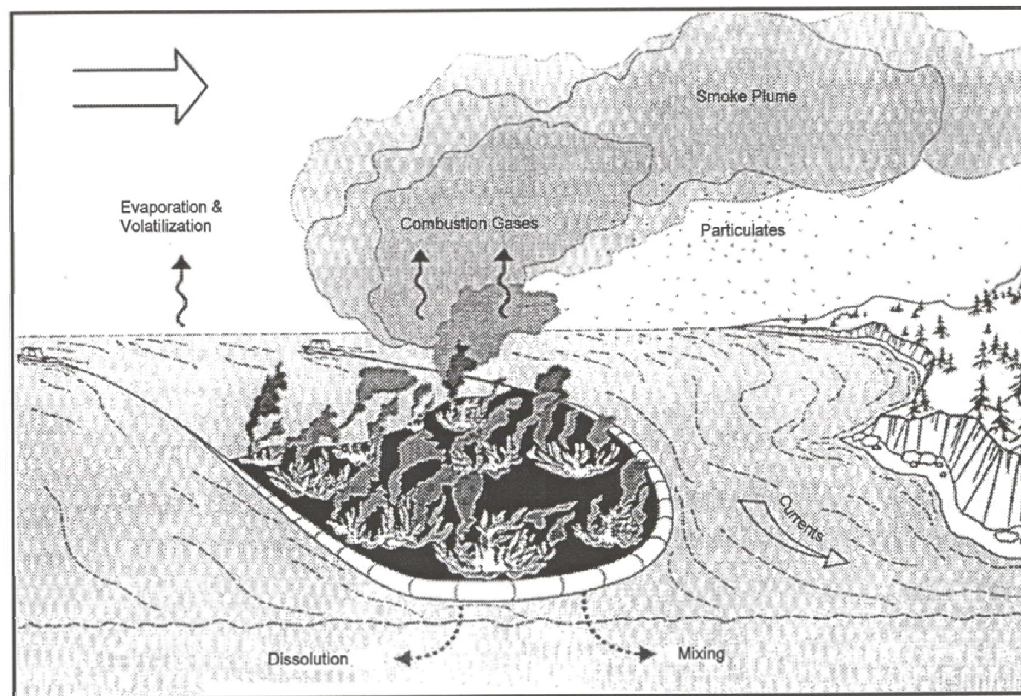

Figure 8-1 Aspects of burning oil on water and pathways for spill and burn products into the environment. (Source: Marine Spill Response Corporation)

Actual operational burns during the DWH spill produced residues that were “a few percent of the original volume [of oil] burned” (Allen, 2011). Burn efficiencies during the Newfoundland Offshore Burning Experiment (NOBE) exceeded 99% (Fingas *et al.*, 1994). Laboratory studies that involved heavier oils or heavily weathered oils produced lower burning efficiencies (61 to 70%) compared to the higher efficiencies (97%) produced by lighter oils. Also in the laboratory, slightly emulsified oils (10 to 15% water) burned with high effectiveness, while burning was less effective (0%) with more emulsified ones (> 65% water) (Brandvik *et al.*, 2010).

The presence of ice in experimental burns did not appear to influence efficiency. Guénette & Wighus (1996) observed high levels of effectiveness (95 to 99%) in burns of fresh and emulsified oils in broken ice. Dickins *et al.* (2008) observed 96% effectiveness in a burn of slightly weathered light crude oil appearing from under ice.

8.3.1.1.2 Residue Composition and Fate

Crude oils contain a very broad range of compounds from the lightest alkanes to the heaviest asphaltenes. During a burn both light and heavy components (HC) of the oil are combusted, but the lighter, lower-boiling point (LBP) HCs are preferentially removed and the heaviest highest-boiling-point (HBP) components are concentrated in the residue. In 1994, there was only limited information concerning changes in chemical composition of the oil caused by the burn. Those data showed a general reduction in the concentrations of VOCs, LMW- and HMW-

PAHs and dioxins/furans and an increase in the concentration of metals in residues compared with parent oils, based on mesoscale burn experiments (Evans *et al.*, 1988; Li *et al.*, 1992)³.

In subsequent work, Buist *et al.* (1995) showed that, in small-scale laboratory burns (5 to 15-cm thick slicks), all HC components with boiling points (BP) < 204°C were eliminated from residues. This would include all aromatics and alkanes < C10. Most components with BP < 538°C were eliminated as well, which would include some of the larger PAHs. The NOBE field experiment showed that after both test burns, the burn residue was greatly depleted in PAHs (*i.e.*, only 25 to 30% of the PAH remained) compared with the parent oil. Fritt-Rasmussen *et al.* (2013) studied the fate of individual species of PAH during burns of fresh and weathered Troll B crude oil in broken ice. They found that LMW PAH like naphthalenes (BP = 218°C) were greatly depleted in burn residue and other PAH including Acenaphthene (BP = 279), fluorine (BP = 295), phenanthrene (BP = 332) were somewhat reduced in residue, while HBP species including anthracene (BP = 340), fluoranthene (BP = 375), and pyrene (BP = 404) were enriched in the residue. The latter confirmed earlier work by Garret *et al.* (2000) who demonstrated that enrichment of the residue in HBP PAH was augmented by pyrogenic PAH species formed during the burn. None of the more recent studies examined changes in VOCs or dioxins/furans in residues.

Another important consideration in the fate of the burn residue is its density, which determines whether the residue will float or sink into the water column following the burn. The notion that density might be important was raised by Moller (1992) following the *Haven* tanker spill (Italy in 1991) and the *Honam Jade* spill (South Korea in 1983) in which burning of the heavy crude oils resulted in some heavy, tarry residue sinking to the sea floor. Contrary to the latter, most experimental evidence to date is that most residues are less dense than water when the fire extinguishes and they float. However, residues of some oils do sink as they cool. Buist *et al.* (1995) showed that in burns of 5 to 15-cm thick slicks of a range of crude oils, residue density is a function of the density of the parent oil and initial slick thickness. In short, in burns of 5-cm thick slicks, the residues of oils with densities greater than 0.88 g/cm³ sank in seawater as they cooled. With thicker slicks (15-cm thick), residues of oils as light as 0.85 g/cm³ sank as they cooled (SL Ross, 1998).

8.3.1.1.3 Effects and Toxicity

Moller's (1992) report that burn residue had sunk and disrupted commercial fishing raised concerns that the sunken residues might cause toxic impacts as well. These concerns were supported somewhat by an earlier report that residue from burning of oil in ice had mutagenic effects in a microbial test (Sheppard and Georgiou, 1981). To date however, there has been little evidence that burn residue poses a toxic risk to biota. The published literature contains reports of residue impacts from only one actual spill, *Haven* (Spain in 1993). Following the *Haven* spill a study of demersal fish collected from areas contaminated with residue (Martinelli *et al.*, 1995) showed some tissue contamination with PAH, but not at a level hazardous to the fish or humans consuming the fish.

Laboratory experimental work has shown some evidence of risk from residue. Blenkinsopp *et al.* (1997) showed water accommodated fraction (WAF) prepared with residue from the NOBE burn test contained very low levels of HC and produced no lethal toxic effects on three-spined

³ The issue of PAHs is presented in great detail in the next chapter.

stickleback at a loading of 1 gm/L. Gulec & Holdway (1999) demonstrated some lethal and sublethal toxic effects in amphipods and snails with prolonged exposure to WAF from burn residue in an enclosed system. The higher toxicity in Gulec compared with Blenkinsopp may be attributable to a higher residue loading rate used by Gulec in preparing the WAF.

8.3.1.2 Water Column

Concerns for water column from burning are related to possible effects of:

- a) Heat transfer from the fire to the underlying water; and,
- b) Increased rates of oil dispersion into water from the burning slick.

8.3.1.2.1 Heat Transfer

Data in 1994 concerning heat transfer from the burn to the water column suggested that although some heat transfer occurs, the effect on water temperature is minor. No observations in work since 1994 have suggested that this view should change. The Alaska Regional Response Team's (2008) In Situ Burning Guidelines note that:

"Burning oil on the surface of the water could adversely affect those organisms at or near the interface between oil and water, although the area affected would presumably be relatively small".

8.3.1.2.2 Dispersion of Hydrocarbons from Burning Slick

Regarding increased dispersion of HC into the water column during burns, evidence suggests that there may be some increase, but that the net increase in environmental risk in burns at sea may be small. On one hand, three studies have examined this problem in laboratory burns: Daykin *et al.* (1994); Gulec & Holdway (1999), and Faksness *et al.* (2011). All three prepared laboratory systems in which oil slicks were laid on water in a laboratory vessel and then burned to extinction in 2 to 25-minutes, testing the underlying water for HC or PAH before and after the burn. All three showed slightly elevated concentrations of HC in water after the burn than before. All three showed that burning caused little or no increase in the toxicity of water under the burning oil. Daykin reported that in NOBE tests, HC concentrations in the upper water column were uniformly very low, with little evidence of elevated oil concentrations in the water after burning.

8.3.1.3 Shorelines

Depending on spill conditions, oil slicks may become stranded on shorelines and must be cleaned up. The methods used and their effectiveness varies with shoreline type. Vegetated shorelines constitute a particular problem because some cleanup methods can do more harm than good. It is important to employ less intrusive oil spill cleanup procedures that minimise the impact to wetland environments. In situ burning of oiled wetlands is considered a useful tool for this, but experience has shown that burning in marshes can be beneficial at times and detrimental at others. Factors such as the season or water level during the burn are important in determining the post-burn recovery. (Hyde *et al.*, 1999; Pahl *et al.*, 1999; Lin *et al.*, 2002).

The literature on in situ burning of oil contaminated wetlands is limited and at times contradictory. For example, an early study found that burning an oiled *Spartina alterniflora* marsh in Texas resulted in better recovery than an unburned marsh, while a later work showed that burning an oiled *S. patens* marsh in Texas had a more negative impact than no action at all. Mendelssohn *et al.* (1995) reviewed in situ burning and concluded that burning is suitable for wetland oil spill cleanup.

Lin *et al.* (2002) showed that water depth over the soil surface during in situ burning is a key factor controlling recovery of the salt marsh grass. Ten-cm of water overlying the soil surface is sufficient to protect marsh soil from burn impacts, while a water table 10-cm below the soil surface resulted in complete inhibition of post-burn recovery. Soil temperature during the burn was the factor determining the speed of post-spill recovery. In a major study, Mendelsohn *et al.* (2000) showed that 2 to 10-cm of water overlying the soil surface was sufficient to protect marsh vegetation from burning impacts. Post-burn plant survival rate was 100%, and growth responses were not significantly different from the unburned control. On the other hand, a water table 2-cm below the soil surface during burns resulted in high soil temperatures and burning impeded post-burn recovery of both salt marsh and freshwater marsh grass species but did not have detrimental effects on brackish marsh grasses.

8.3.2 Airborne Emissions

The airborne emissions (smoke plume) from in situ burning are of interest in Arctic burns, as well as elsewhere because of the potential for risks to responders, nearby civilian populations and to the environment. There is no data on the effects of in situ burning airborne emissions on species other than humans so this section concentrates on human exposure. Emissions from ISB have been studied heavily over the past three decades in laboratory, mesoscale and field tests, as well as in the recent DWH spill. These studies have been reviewed by several authors, including Allen & Ferek (1993), Fraser *et al.* (1997), Buist *et al.* (1999), Evans *et al.* (2001), and Fingas (2011). Burn plumes contain a number of components; those that are of greatest interest because of their abundance or hazard potential are given in **Tables 8-1** and **8-2**. It is important to recognise that smoke composition varies somewhat depending on the burn conditions. Each component in the table is discussed separately below.

Table 8-1: More abundant smoke components ^a	
Component	Mass per kg of oil burned ^b
Carbon Dioxide, CO ₂	3-kg
Smoke Particulates ^c	0.02 –0.20-kg
Carbon Monoxide (CO)	0.02 - .05-kg
Volatile Organic Carbon (VOCs)	.005
Nitrogen Oxides (NO _x)	.001
Polynuclear Aromatic Hydrocarbons (PAH)	0.000004
Water	1.2-kg
a) From Buist <i>et al.</i> , 1999. b) Booher & Janke, 1997 amended with Fingas, 2011 c) Quantities will vary with burn efficiency and composition of parent oil.	

8.3.2.1 Particulate Matter or Smoke

Carbon particles are a major component of the emissions plume, giving the smoke plume its characteristic black colour. These smoke particles, also called soot or carbon black, are unsightly, but more important, can cause severe health problems if inhaled in sufficient concentrations. Of particular concern are risks to persons with special sensitivities, such as the very young, the very old, pregnant women, and persons with asthma, pulmonary, and vascular diseases. Particulates are hazardous on their own, but they also serve to carry other adsorbed toxic materials (e.g., PAHs) deep into the respiratory tract. They are also of concern because they obstruct visibility and hence may pose a safety hazard to operators of ships, aircraft and motor vehicles in the immediate vicinity of the fire.

Table 8-2: Air Quality Standards					
Contaminant (units)	Averaging Periods				
	1-hour	3-hour	8-hour	24-hour	Annual
U.S. National Ambient Air Quality Standards and Alaska State Regulatory Standards					
CO ₂ (ppm)					
PM _{2.5} (µg/m ³)	—	—	—	35	15
PM ₁₀ (µg/m ³)	—	—	—	150	50
CO (PPM)	35	—	9	—	—
SO ₂ (µg/m ³)	—	1,300	—	365	80
NO ₂ (µg/m ³)	—	—	—	—	100
OSHA Permissible Exposure Limits					
CO ₂ (ppm)	—	—	5,000	—	—
Total particulates (ug/m ³) (PEL)	—	—	3.5 (35)	—	—
Respirable particulates (mg/m ³)	—	—	5	—	—
CO (ppm)	—	—	50	—	—
**SO ₂ (ppm)	—	—	5	—	—
***NO ₂ (ppm)	—	—	5	—	—
PAH (mg/m ³)	—	—	0.2	—	—
Benzene (in VOC) (ppm)	—	—	1	—	—

8.3.2.1.1 Smoke yield

Smoke yield, the amount of smoke produced relative to the amount of oil burned, has been the subject of controversy in the past, however several major reviews appear to agree on the following. Smoke yields from dozens of burn experiments conducted in the late 1980s and 1990s, plus the oil pool fires in Kuwait range from 2% to 20% of oil burned (Evans *et al.*, 2001; Fingas, 2011). A thorough analysis of test burns concluded that within this range the most important factor controlling smoke yield was the size (diameter) of the fire (although natural

variability was high). Results of recent work on burning emulsions agreed with this (Garo *et al.*, 2004). Early results from monitoring of ISB operations during the DWH spill (United States in 2010) indicate that approximately 4% of oil burned on one-day (of the 40-days on which burns were conducted) was emitted as smoke that existed in the atmosphere 200-m above the sea surface 8-km or more downwind of the burns (Middlebrook *et al.*, 2012).

8.3.2.1.2 Smoke Particle Size

The health impacts of inhaling airborne particulate matter include asthma, lung cancer, cardiovascular and respiratory diseases, birth defects, and premature death. The hazard posed by smoke particles depends heavily on particle size (diameter) because size determines where an inhaled particle will come to rest in the respiratory tract. Particles larger than 10- μm can be filtered in the nose and throat and hence pose little health risk and thus are not regulated. Particles < 10- μm diameter can penetrate into the lungs and particles < 4 μm can penetrate into the deepest part of the lungs, such as the bronchioles or alveoli to cause health problems. These are regulated as PM10. Particles < 2.5- μm can penetrate into the gas exchange regions of the lung. These are regulated as PM2.5. Very small particles (< 0.1 μm) can pass through the lungs to affect other organs (PM0.1), but as yet are not regulated. The particle-size distribution in smoke produced in the NOBE burn #2 is in **Figure 8.2**. PM10s make up 85% of the smoke in this plume and PM2.5 made up 65%. This size distribution is typical of smoke from oil pool fires.

Smoke exposure safety during in situ oil burns is based on the U.S. National Ambient Air Quality Standard (NAAQS) (**Table 8-2**). That standard is based on PM2.5 concentrations and is 35-ppm averaged over a 24-hour period. The safe exposure standard for in situ burn operations is the distance from the fire at which emissions near ground (or sea) level diminish to 1-hour concentrations equal to their NAAQS concentrations averaged for 24-hours or less (ARRT, 2008).

8.3.2.1.3 Smoke Concentrations and Modeling

Particulate concentrations in the plume are greatest at the burn site, but decline with increasing distance from the burn site primarily through dilution, dispersion and fallout, but also through washing out by rain and snow. At the 1993 Newfoundland Offshore Burn Experiment (NOBE), two large in situ burn tests were completed and smoke concentrations were measured in the plume and elsewhere. Smoke plumes from both 23- m^3/h burns rose

quickly to altitudes of 200 to 400-m above the sea, then rose more slowly to 800-m at 30-km from the burn. Concentrations of total particulates in the plumes near the fire were 800 to 1200 $\mu\text{g}/\text{m}^3$ (concentrations of particles < 3.5- μm were 700 to 1100 $\mu\text{g}/\text{m}^3$), but declined quickly to 100 to 150 $\mu\text{g}/\text{m}^3$ at 1 to 1.5-hours drift time from the spill site (= 30 to 40-km distance from the burn site, given winds of 20 to 35 km/h; Walton *et al.*, 1994). Of particular importance is the fact

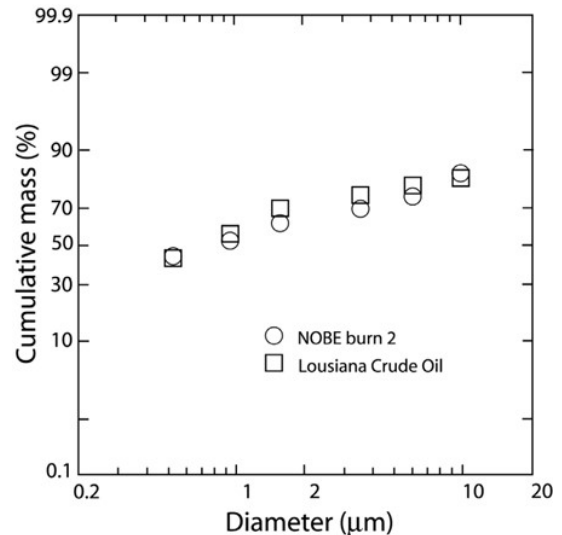

Figure 8-2 Particle size distributions in smoke plumes from large in situ burns. (From Evans *et al.* 2001)

that PM10 concentrations beneath the plume, even 50 to 70-m above the sea surface, never exceeded background levels (30 to 40 $\mu\text{g}/\text{m}^3$). Ground-level concentrations beneath a plume from a test burn of crude in Alaska with a burn rate 20 m^3/h declined from 86 $\mu\text{g}/\text{m}^3$, 1-km downwind, to 22 $\mu\text{g}/\text{m}^3$ at 4-km downwind. Measurements of near-ground smoke concentrations under the plume from two even larger diesel fires (70 m^3/h) in Mobile, AL in 1994 peaked at only 25 $\mu\text{g}/\text{m}^3$ at 11-km downwind in one case and 15 $\mu\text{g}/\text{m}^3$ at 11-km downwind in the other (Evans *et al.*, 2001).

Concentrations of PM2.5 in a smoke plume are not easy to predict because they are a function of many factors including soot yield, fire size, burn efficiency, distance downwind from the burn, terrain features and atmospheric conditions (e.g., wind speed). To help decision makers, computer models have been developed to estimate the concentration of soot particles in a burn plume as a function of altitude and distance from the fire. Such models can be of assistance in estimating safe distances from the fire and deciding whether or not to initiate an in situ burning operation when close to populated areas. Some of these models are highly sophisticated and should be run only by experts. However as a planning aid, NIST has developed a simple tool for estimating the maximum distance over flat or complex terrain for concentrations in smoke plumes from ISBs to dilute to below a given concentration. This tool is discussed in detail in **Section 8.5.2**.

8.3.2.2 Gases

Unlike particulate matter, the gases emitted during an in situ burn operation generally do not represent a serious threat to safety or human-health. This is primarily because the concentrations at which they become hazardous are much higher than those for the particulate soot. The concentrations of gases in the smoke plume may exceed hazard thresholds as they leave the fire, but they decline below these thresholds within very short distances from the fire. A brief summary of each gas is presented below.

8.3.2.2.1 Carbon dioxide (CO₂)

Carbon dioxide (CO₂) is the most abundant component of the smoke plume. CO₂ is a common atmospheric component, composing 0.039% of the atmosphere by volume (background concentration in air = 300-ppm). It is non-toxic, but at concentrations > 2% can cause sub lethal effects (e.g., confusion, increased blood pressure and respiratory rate) and at concentrations > 10% can cause suffocation. Concentrations at ground level at 30-m from mid-scale fires averaged from 200 to 1100-ppm. This is above background, but well below the hazardous levels.

8.3.2.2.2 Carbon monoxide (CO)

Approximately 2 to 5% by weight of crude oil consumed during in situ burning is converted to CO. CO is toxic, attacking the respiratory and nervous systems. The acceptable exposure level for CO is 35 $\mu\text{g}/\text{m}^3$ for 1-hour and 9-ppm for 8-hours. Industrial exposure standards are: the threshold limit value (TLV-TWA) is 25-ppm (or 29 mg/m^3) averaged over 8-hours. Measurements of CO made at several burn tests show that at ground level, 30-m downwind of an in situ oil fire, ambient concentrations of CO were at or near background levels or were below the limits of detection of the instruments. This suggests that there is little risk of effects from CO at ground level.

8.3.2.2.3 Volatile organic compounds (VOCs)

VOCs are a mixture of the lighter, LMW HC, including benzene. These compounds are released into the air during oil spills, whether burning is used or not. VOCs cause irritation to eyes, nose, and throat and may cause damage to liver, kidney, and central nervous system at higher exposures. During any petroleum spill, the lighter, more volatile components of the oil evaporate quickly, causing elevated concentrations of VOCs in the air downwind of the slick. This process is rapid and much of this material is lost from the slick within the first 24 to 48-hours. During the DWH, VOCs given off from slicks at the spill site were of sufficient concern that dispersants were used to disperse the slicks and minimise VOC emission. When slicks are ignited and burned, some VOCs are consumed by the fire so the net discharge of VOC at the spill site declines.

At present U.S. EPA has no safety standard for VOCs as such. However, the most abundant component of VOC in emissions from oil burns is benzene (Booher & Janke, 1997) and the EU has a standard for benzene exposure of $5 \mu\text{g}/\text{m}^3$. During the Mobile mid-scale burns, VOC concentrations at ground level, within 30-m downwind of the fires averaged approximately $2 \mu\text{g}/\text{m}^3$ with peak average concentrations reaching $10 \mu\text{g}/\text{m}^3$. At 60-m downwind, average concentrations were $0.8 \mu\text{g}/\text{m}^3$, with peaks to $1.5 \mu\text{g}/\text{m}^3$, which are well below the safety standard for exposure to such vapours.

8.3.2.2.4 Sulfur dioxide (SO_2)

SO_2 is a minor product of oil spill fires. Short-term exposures to SO_2 (5-minutes to 24-hours) are linked to adverse respiratory effects including broncho-constriction and increased asthma symptoms. Its concentration in the smoke is dependent on the amount of sulfur in the oil. The exposure standard for the U.S. is $75 \mu\text{g}/\text{m}^3$ averaged over 1-hour. Measurements of SO_2 taken at ground level at the NOBE experiment were all below detection levels.

8.3.2.2.5 Nitrogen oxides (NO_x)

NO_x are gases present in small amounts in emissions from oil fires. Nitrogen dioxide is somewhat toxic by inhalation causing decreased lung function and increase the risk of respiratory symptoms. During NOBE and other mid-scale test burns, concentrations of NO_x at ground level downwind of the fire were below the limits of detection and levels of concern.

8.3.2.2.6 Polynuclear Aromatic Hydrocarbons (PAH)

PAH are a family of dozens of aromatic hydrocarbons with two or more fused rings. They are of interest because certain PAH compounds, such as benzo[a]pyrene, benzo[k]fluoranthene and chrysene are known to cause cancer in laboratory animals. PAHs are present in small, but varying amounts in petroleum oils, burn residue, and smoke. The ambient concentrations of particle-bound PAH in "clean" air near the fire are on the order of a few mg/m^3 (based on data from the Mobile mid-scale burns and NOBE). Concentrations measured at ground level near the fire appear to be well below accepted workplace exposure standards, and hence the risks to spill workers would appear to be low.

8.3.2.2.7 Dioxins

During the DWH in situ burning operations, the U.S. EPA measured dioxin emissions in the smoke plumes from 27 burns on the water using an aerostat (balloon) over a period of four days. The emission rate of dioxins was estimated to be 1.7-ng toxic equivalency (TEQ) per kg of oil burned. The average plume concentration approximately 200 to 300-m from the fire and

about 75-200-m above sea level was $< 0.0002 \text{ ng TEQ/m}^3$ (Aurell & Gullett, 2010), well below air emission standards for waste incinerators and industrial processes.

8.4 Human Hazards and Health Effects

Human health and safety concerns surrounding in situ burning fall into four categories:

1. Physical hazards to cleanup workers and nearby residents;
2. Hazards related to ingestion of residues or burn products (eating or drinking);
3. Hazards from the inhalation of airborne burn products; and
4. Hazards from dermal contact with burn products.

The following review discusses the effects of in situ burning on human health under each of these four categories.

8.4.1 Physical Hazards

Physical risks to workers and the general public related to in situ burning are those arising from explosions, heat, or loss of control of burning oil (including flashback to the spill source and loss of containment of boomed burns). These hazards affect spill response workers more than the general public. Securing the spill site will further reduce potential hazards to the public. No documented injuries from use of in situ burning as a countermeasure have been recorded, but flames and intense heat are obviously a serious potential threat to the health and safety of anyone near the burn. Case studies of actual burns reveal that spill response workers must be properly supervised and trained to avoid serious injuries in burning situations (Robertson, 1991). Specifically, workers should understand that the safe distance from an oil fire varies with the amount of heat generated from the fire (a function of the fire diameter) and the exposure time (Buist et al., 1999). In general, approaching a fire from a distance of 4 fire-diameters is reasonable. The table below lists safe approach distances.

Exposure Time	Safe Approach Distance (in fire diameters)
Infinite	4
30 min	3
5 min	2

8.4.2 Air Quality and Inhalation

One major concern with in situ burning is the potential for acute or longer-term effects of the smoke inhalation on human health. Airborne burn products that may affect human health include smoke particles, carbon monoxide, sulfur dioxide, PAHs, VOCs and metals. Exposure to these burn products will depend on the proximity of people to the burn, the volume of oil burned, the efficiency of the burn, wind direction and speed, and atmospheric stability. Weather may also be a factor since rain and snow will influence the fate of burn emissions. Risks from each of the significant burn emission products are discussed below.

No studies were found that directly document the effects of in situ burning of marine oil spills on human health. A number of studies involving research on wildfires, and vehicle and power

plant emissions have provided information on effects of burn products on human health and much of the following is based on these studies. The burn products include CO, NO and SO₂ and particulates. Human health criteria and air quality standards established by Federal and State agencies identify the exposure limits of certain chemicals and particulates that, if exceeded, pose a threat to human health.

The Kuwait oil fires of 1991 provided an opportunity to study the transport and effects of burn products on a large scale. Studies performed during May and June 1991 indicated that the fires consumed approximately 4.6 million barrels of oil per day ($0.73 \times 10^6 \text{ m}^3/\text{d}$) in the Greater Burgan field alone (Ferek *et al.*, 1992). Workers estimated that approximately 2% of the mass of fuel burned resulted in particulate matter in smoke (Ferek *et al.*, 1992; Laursen *et al.*, 1992). PAHs and heavy metals were in low concentrations in smoke samples taken from populated areas or from oil fields (Campagna & Humphrey, 1992).

Middlebrook *et al.* (2012) summarized air testing data obtained by NOAA aircraft during the DWH oil spill in 2010. On June 8 and June 10, following the April 20, 2010 explosion and well leak, air testing data were obtained from altitudes of 200-m in the DWH spill region and in the downwind plume. Air pollutants were emitted from hydrocarbons evaporating from the oil, smoke from in situ burns, combustion products from the flaring of recovered natural gas from the well, and the ship emissions from the clean-up operations.

The largest component of the air pollutants, based on mass, was the hydrocarbons evaporating from the oil. The highest level of particulates in the submicron range was 20 $\mu\text{g}/\text{m}^3$, and mass spectra analysis of the aerosol particles downwind of the DWH showed that polynuclear aromatic hydrocarbons (PAHs) were less than 0.1% of the particulate mass. Analysis of the smoke showed that black carbon was the main constituent. Levels of pollutants measured in the DWH region were similar to levels found downwind and are reported in [Table 8-4](#). Levels of SO₂ were not reported.

For comparison, [Table 8-5](#) shows the Ambient Air Quality Standards for the United States, Canada and the European Commission (EC). The maximum level of ozone reported in the plume by Middlebrook *et al.* (2012) was below the air quality standards for the US, and EC, but above the Canadian value of 15-ppb. The maximum air levels of CO and NO₂ were well below air quality standards. The particulate levels reported by Middlebrook *et al.* (2012) did not include non-volatile material or particles larger than approximately 0.6 microns in diameter, and health-based standards or guidelines for this subset of particulates are not available. Levels of benzene and toluene were well below occupational and community exposure standards and guidelines (see [Table 8-2](#)). Particulates less than 10- μm in diameter (PM10) and less than 2.5- μm in diameter (PM2.5) pose the greatest concern for respiratory and cardiovascular effects, particularly in the elderly and in children.

Chemical	Average (ppbv)	Maximum (ppbv)
Ozone	47	50
Carbon monoxide	139	143
Nitrogen dioxide	0.6	4.4
Benzene	0.1	1

Toluene	0.2	2.5
Naphthalene	0.1	0.4
Aerosol total mass ^b	8.7	13.5
^a See text for details		
^b Does not include non-volatile material or particles larger than about 0.6 microns in diameter		

Table 8-5: Comparison of Criteria Pollutant Ambient Standards (U.S. EPA, 2012; CCME, 1999; European Commission, 2012)

Pollutant	Averaging period	U.S. National Ambient Air Quality Standards ^a		Canada	EC
		Primary	Secondary		
PM10	24-hr	150 µg/m ³	150 µg/m ³	-	50 µg/m ³
PM2.5	Annual	15 µg/m ³	15 µg/m ³	10 µg/m ³	25 µg/m ³
	24-hr	35 µg/m ³	35 µg/m ³	30 µg/m ³	-
CO	8-hr	9 ppm (10.3 mg/m ³)	-	5 ppm ^b (6 mg/m ³)	8.7 ppm (10 mg/m ³)
	1-hr	35 ppm (40 mg/m ³)	-	13 ppm ^b (15 mg/m ³)	-
NO ₂	Annual	53 ppb (99 µg/m ³)	53 ppb (99 µg/m ³)	32 ppb ^b (60 µg/m ³)	21 ppb (40 µg/m ³)
	1-hr	100 ppb (188 µg/m ³)	-	220 ppb ^c (400 µg/m ³)	110 ppb (200 µg/m ³)
SO ₂	24-hr	-	-	57 ppb ^b (100 µg/m ³)	48 ppb (125 µg/m ³)
	3-hr	-	500 ppb (1,309 µg/m ³)	-	-
	1-hr	75 ppb (196 µg/m ³)	-	170 ppb ^b (450 µg/m ³)	130 ppb (350 µg/m ³)
Ozone	8-hr	75 ppb (147 µg/m ³)	75ppb (147 µg/m ³)	-	61 ppb (120 µg/m ³)
	24-hr	-	-	15 ppb ^b (30 µg/m ³)	-

^a Adopted by Alaska
^b Desirable level (REF)
^c Acceptable

The U.S. 24-hour exposure standard for PM10 is 150 µg/m³, and for PM2.5 is 35 µg/m³ (Table 8-5). Ultrafine particles (less than 0.1-µm) may also be associated with health effects; however, no specific standards for these particles have been set to date. The World Health Organization (WHO) states:

“In addition to PM_{2.5} and PM₁₀, ultrafine particles have recently attracted significant scientific and medical attention. These are particles smaller than 0.1 μm and are measured as number concentration. While there is considerable toxicological evidence of potential detrimental effects of ultrafine particles on human health, the existing body of epidemiological evidence is insufficient to reach a conclusion on the exposure–response relationship to ultrafine particles. Therefore no recommendations can be provided at present as to guideline concentrations of ultrafine particles.” (WHO 2006)

Several organizations, including the U.S. Environmental Protection Agency (U.S. EPA), the California Office of Environmental Health Hazard Assessment (OEHHA), and the World Health Organization (WHO) have all published guidelines and recommendations related to wildfire particulate air quality and potential health impacts for sensitive populations. **Table 8-6** is a summary of the recommendations of these organizations.

In the mesoscale tests run in Mobile, Alabama in 1991 and 1992⁴, the peak concentration of particles commonly measured 10,000 to 30,000 μg/m³ and 4000 to 10,000 μg/m³ at ground level stations at 33-m and 66-m, respectively, downwind of the fires. These values greatly exceed the 24-hour standard. On the other hand, the average concentrations at these stations ranged from 40 to 2690 (mean = 750) μg/m³ and 10 to 1500 (mean = 249) μg/m³ (Fingas *et al.*, 1993). These however, are small fires compared with the 1000 barrel parcels of oil likely to be burned during actual spill operations (the in situ burn rates at the DWH spill response averaged about 600 to 800 bbl/h).

NIST (ALOFT-FT Walton *et al.*, 1996; and ALOFT-CT McGrattan *et al.*, 1997), NOAA (*In-situ* Burn Calculator; http://response.restoration.noaa.gov/resource_catalog.php) and Environment Canada (Fingas & Punt, 2000) have developed computer models to predict downwind smoke concentrations. The first two are sophisticated tools that require detailed spill and meteorological inputs and should be run by experts only. As an interim planning measure, general examples can be used as guides. NIST has developed a simple technique for roughly estimating the maximum distance downwind over flat or complex terrain for the concentration of soot in plumes from ISBs to dilute and disperse below a given concentration (McGrattan *et al.*, 1977). The distance beyond which the soot concentration falls below a given level depends mainly on the terrain height and the mixing layer depth relative to the elevation of the burn site, with wind speed being the next most important factor. **Table 8-7** lists the approximate maximum distances downwind over land for the ground-level PM₁₀ (particulate matter smaller than 10 microns in diameter) concentrations from 1,000 and 2,000 bbl/h fires, to fall below 150 μg/m³ for various terrain heights in winds from 1 to 12 m/s. The tabulated results are consistent with a similar table produced by Environment Canada (Fingas & Punt, 2000).

If the plume passes over highly elevated terrain, the distances at which the ground-level concentrations of PM₁₀ decrease below 150 μg/m³ are much greater than over flat terrain in equivalent meteorological conditions. The distance downwind for the smoke plume to dilute below 150 μg/m³ would range from 1-km over flat terrain in a highly mixed atmosphere to 20-km over mountainous terrain in a very stable atmosphere. Low mixing-layer depths (very stable atmospheres) generally only occur at night. Mixing layer depths loosely correspond to atmospheric stability class ranges as follows: Stability Class C, 200 to 300-m; Stability Class D,

⁴ Burns involved 7570 to 18,925-L of Louisiana crude burned in 15.5-m x 15.5-m pans.

150 to 200-m; Stability Class E, 100 to 150-m. The atmosphere over water is generally less well mixed than over land and a good rule of thumb is that it takes about twice the distance over water to achieve the same decrease in smoke plume concentrations as it does over land, using the "Flat" terrain height category. Mixing zone heights over large bodies of water are usually in the range of 150 to 300-m.

Table 8-6: Comparison of Action Levels and Associated Recommendations for Particulate Matter Associated with Wildfires (from OEHHA, 2008; U.S. EPA, 1999; Schwela *et al.*, 1999)

Levels of Health Concern	PM10 Levels	PM2.5 or PM10 Levels	U.S. EPA ¹ and WHO ² Cautionary Statements	OEHHA ³ Recommended Actions	Suggested Respiratory Protection – WHO ³
	(ug/m ³ , 24-hour average) - EPA	(ug/m ³ , 1-3-h average) – OEHHA			
Good	0 - 54	0 – 40	None	If smoke forecast, implement communication plan	None
Moderate	55 - 154	41 - 80	Unusually sensitive people should consider reducing prolonged or heavy exertion. (U.S. EPA) Mild aggravation of symptoms (150 µg/m ³ – WHO)	Issue public service announcements advising about health effects / symptoms & actions Distribute information about exposure avoidance	None
Unhealthy for Sensitive Groups	155 - 254	81 – 175	People with heart or lung disease, older adults, and children should reduce prolonged or heavy exertion. (U.S. EPA)	If projected smoke event prolonged, notify possible sites for clean air shelters & prepare evacuation plans	None
Unhealthy	255 - 354	176 – 300	People with heart/lung disease, older adults, and children avoid prolonged/heavy exertion. Others reduce prolonged/heavy exertion. (U.S. EPA) Significant aggravation of symptoms and decreased exercise tolerance in susceptible groups. (350 µg/m ³ – WHO)	Consider “Smoke Day” for schools, possibly based on school environment and travel conditions Consider canceling public events	N95 for susceptible individuals involved in outside activities (> 350 µg/m ³)
Very Unhealthy	355 - 424	301 – 500	People with heart or lung disease, older adults, children avoid physical activity outdoors. Others avoid prolonged, heavy exertion. (U.S. EPA)	Consider closing some or all schools. Cancel outdoor events (e.g., concerts, sports)	N95 for susceptible individuals for outside activities (> 350 µg/m ³)

Table 8-6: Comparison of Action Levels and Associated Recommendations for Particulate Matter Associated with Wildfires (from OEHHA, 2008; U.S. EPA, 1999; Schwela et al., 1999)

Levels of Health Concern	PM10 Levels	PM2.5 or PM10 Levels	U.S. EPA ¹ and WHO ² Cautionary Statements	OEHHA ³ Recommended Actions	Suggested Respiratory Protection – WHO ³
	(ug/m ³ , 24-hour average) - EPA	(ug/m ³ , 1-3-h average) – OEHHA			
Hazardous	425 - 604	>500	<p>People with heart/lung disease, elders, children remain indoors/keep activity low. Others avoid outdoor physical activity. (U.S. EPA)</p> <p>Premature onset of certain diseases, significant aggravation of symptoms and decrease exercise tolerance in healthy persons. (500 µg/m³ – WHO)</p> <p>Premature death in the ill and elderly. Healthy people suffer adverse symptoms affecting activity. (600 µg/m³ – WHO)</p> <p>Acute/incapacitating symptoms suffered by much of population. (800 µg/m³ – WHO)</p>	<p>Close schools</p> <p>Cancel outdoor events (e.g., concerts and competitive sports)</p> <p>Consider closing workplaces not essential to public health</p> <p>If PM level projected to continue to remain high for a prolonged time, consider evacuation of sensitive populations</p>	<p>N95 for healthy people involved in outside activities (> 500 µg/m³)</p> <p>N95 for susceptible people in indoor facilities without atmospheric controls (> 600 µg/m³)</p> <p>N95 for health persons in indoor facilities without atmospheric controls (> 800 µg/m³)</p>

¹ U.S. EPA Air Quality Index Reporting, 40 CFR 58 (pages 42530-42549), August 4, 1999.
² Schwela, et al., 1999. Health Guidelines for Vegetation Fire Events. Guideline document.
³ OEHHA, 2008. Wildfire Smoke: A Guide for Public Health Officials.

Fire Size	Kilometres downwind for one-hour average PM-10 soot from a crude burn to fall below 150µg/m ³					
	Terrain Height (m)	Mixing Layer Depth (m)				
		0 to 100	100 to 250	250 to 500	500 to 1000	> 1000
1000 bbl/h (160 m ³ /h)	0 to 25 (flat terrain)	5	4	3	2	1
	25 to 250	10	8	6	4	3
	250 to 500	15	12	10	8	5
	> 500	20	17	15	12	10
2000 bbl/h (320 m ³ /h)	0 to 25 (flat terrain)	7	6	5	4	3
	25 to 250	12	10	8	6	5
	250 to 500	17	14	12	10	7
	> 500	22	19	17	14	12

Table 8-7: Simplified tabular results of the ALOFT FT and ALOFT CT Soot Dispersion Models

Table 8-8 shows the data from Table 8-7 adjusted using the equation given in McGrattan et al. (1997) to account for a lower target concentration of PM10, specifically 50 µg/m³ which is the ambient air quality standard in the European Union (EU).

Table 8-9 shows the data from **Table 8-7** adjusted using the equation given in McGrattan *et al.* (1997) to account for a soot particle size range (PM2.5) and standard concentration of 35 µg/m³, which is the prevailing ambient air quality standard in North America (35 µg/m³ in the United States and 30µg/m³ in Canada).

Concentrations of CO measured at ground level and in smoke plumes during the above mesoscale burns were consistently near background values (Fingas *et al.*, 1993). On the other hand, concentrations of SO₂ within the smoke plume near the burn site reached levels of 4.4 to 14.2-ppm, which exceed all air quality standards. However, average SO₂ concentrations downwind fell below critical threshold values (**Table 8-5**) within 100-m of burn sites in these tests.

The lighter hydrocarbons in spilled oil pose a health threat regardless of whether the spill is burned or not. Exposure to these hydrocarbons by inhalation poses the greatest risk because the absorption of hydrocarbons through the lungs generally is highly efficient. Following the *Amoco Cadiz* spill which reportedly released about 40,000-tonnes of light hydrocarbon crude into the atmosphere, workers and coastal inhabitants reported symptoms of acute petroleum vapour toxicity, including headaches, dizziness, nausea, sensations of inebriation, vomiting, and abdominal pain (Menez *et al.*, 1978; Dowty *et al.*, 1981). Burning of such spills could reduce the exposure of workers and coastal inhabitants to the fumes of evaporating oil, but only at the risk of exposing them to the products of combustion.

Some PAHs in burn products have been identified as having carcinogenic potential (Grimmer *et al.*, 1991). Concentrations of these chemicals will vary depending on environmental conditions during the burn. The potential risk from these compounds is described in the next chapter.

Table 8-8: ALOFT Models modified for PM10 50 µg/m³ Soot Target Concentration / Particle Size

Fire Size	Kilometres downwind for one-hour average PM-10 soot from a crude burn to fall below 50 µg/m ³					
	Terrain Height (m)	Mixing Layer Depth (m)				
		0 to 100	100 to 250	250 to 500	500 to 1000	> 1000
1000 bbl/h (160 m ³ /h)	0 to 25 (flat terrain)	13	12	11	10	9
	25 to 250	18	16	14	12	11
	250 to 500	23	20	18	16	13
	> 500	28	25	23	20	18
2000 bbl/h (320 m ³ /h)	0 to 25 (flat terrain)	14	13	12	11	10
	25 to 250	19	17	15	13	12
	250 to 500	24	21	19	17	14
	> 500	29	26	24	21	19

Table 8-9: ALOFT Models modified for PM_{2.5} 35 µg/m³ Soot Target Concentration / Particle Size

Fire Size	Kilometres downwind for one-hour average PM-2.5 soot from a crude burn to fall below 35 µg/m ³					
	Terrain Height (m)	Mixing Layer Depth (m)				
		0 to 100	100 to 250	250 to 500	500 to 1000	> 1000
1000 bbl/h (160 m ³ /h)	0 to 25 (flat terrain)	12	11	10	9	8
	25 to 250	17	15	13	11	10
	250 to 500	22	19	17	15	12
	> 500	27	24	22	19	17
2000 bbl/h (320 m ³ /h)	0 to 25 (flat terrain)	14	13	12	11	10
	25 to 250	19	17	15	13	12
	250 to 500	24	21	19	17	14
	> 500	29	26	24	21	19

The U.S. EPA used the sample data on dioxin concentrations in smoke plumes (Aurell & Gullett, 2010) from the DWH burn operations in computer models to estimate dioxin exposures to workers near the burns and residents at further distances (Schaum *et al.*, 2010). The lifetime incremental cancer risks were extremely low: 6×10^{-8} for workers, 6×10^{-12} for residents and 6×10^{-8} for fish consumption. EPA usually considers the risk range 10^{-6} to 10^{-4} to be where additional actions should be considered.

Despite the apparent potential risks, no reports have been found in the literature of injuries or health effects from smoke or fallout despite the numerous oil fires resulting from tank car fires, accidental oil tanker burns, or burning oil well blowouts. As might be expected, any effects on human health have been acute, such as death due to explosions or asphyxiation resulting from smoke inhalation by personnel present during the accident. Ship fires, such as the *Haven* and *Aegean Sea*, which have occurred within a kilometre or two of populated areas, have not resulted in any known impact. In the latter case, smoke from the fire was carried directly over the city of La Coru a requiring officials to evacuate nearly 100 homes near the harbour. Despite the proximity, no acute affects were reported. Similarly, intentional burns of oil on marshes, which is a common practice in Texas and Louisiana, have resulted in no known impacts to human health.

In summary, burning of oil reduces the length of time that fumes from evaporating oil may pose a threat to spill workers or the public, but the trade-off is that chemicals and particulate in the burn emission may affect health. Potentially harmful burn products include particulate carbon, PAHs, VOCs, NO_x and SO₂. The concentrations of these pollutant chemicals will vary depending on environmental conditions during the burn, and as such can be more accurately predicted at the time of the burn for local conditions. Data from mesoscale burns and computer simulations suggest that potentially hazardous exposure conditions may exist near the burn site during the period of the burn. A more detailed consideration of risk will be undertaken in the following chapter (Chapter 9).

8.4.3 *Water Column and Ingestion*

Risks from hydrocarbon components of unburned and combusted oil spills are discussed elsewhere in **Chapter 7, Section 8.3.1.1** and **8.3.1.2** above and are not addressed here.

8.4.4 *Dermal Contact*

Acute dermal exposure of humans to fresh crude oil and refined products can result in dermatitis and skin injury. Politzer *et al.* (1985) reported specific information about dermal effects of a number of petroleum products. Effects in animals generally include sporadic diarrhea and dermal irritation; few systemic effects have been reported. Primary dermal irritation is greatest for middle distillates and kerosene, which elicited blanching, subcutaneous hemorrhage, and fissuring. Workers with direct contact to oil during the *Amoco Cadiz* oil spill reported skin irritation and erythema on hands and limbs, although no systemic effects were found from examination of blood.

Direct contact of smoke and burn residue with skin is not expected to be a hazard to health. Smoke particulates may contact the skin as they precipitate; however, people in populated areas are exposed daily to combustion products from car emissions, with no apparent injury. Dermal contact with the burn residue on water is a hazard mainly to cleanup workers; however, these individuals should be equipped with appropriate protective clothing and should be trained in procedures for the safe handling of oil and oily waste.

8.4.5 *Other Effects and Impacts*

Other potential effects of an in situ burn include impacts on visibility, aesthetic values, local human use activities, and transportation. Smoke plumes will reduce visibility at a local scale and may require changes in air traffic routing or road closures. The smoke plume and particulate deposition may also cause limited spatial and temporal aesthetic impact. Reports of soot deposition at small villages downwind of the burn during the *Exxon Valdez* response indicated a perceived aesthetic and visual impact to the local communities. Human use activities such as fishing (commercial and sport), recreation, and tourism may be temporarily affected by the requirements to provide a safety zone around the burn area.

8.4.6 *Summary*

A literature search identified little published evidence of health or environmental effects from burning in either actual spills or in laboratory tests. However, a number of studies have examined the composition and environmental fate of burn emissions. These studies showed that at least some burn emissions (e.g., particulate carbon, sulfur dioxide) may pose a threat to wildlife or human health in the area immediately downwind of a burn, but exposure conditions would fall below threshold levels within, at most, a few kilometres downwind of the burn. Air samples taken during the *Deepwater Horizon* in situ burning operations appear to corroborate this.

Burn residues appear to pose little threat to aquatic resources and human use of water resources. In addition, the volume of residue left after a burn would be much reduced over the parent spill and the toxicity of the residue appears to be similar to that of the normally weathered, unburned oil. As a consequence environmental risks from burning would appear to be minor.

Case studies of burns in major spills have revealed no significant impacts to human or ecological resources. Spills in which tankers have caught fire have resulted in little if any impact of the smoke plume or burn residue on the environment and even the most significant burn event ever experienced, the Kuwait oil fires of 1991, does not appear to have caused lasting environmental or human health impacts.

References to Chapter 8

- Alaska Regional Response Team (ARRT). 2008. **In Situ Burning Guidelines for Alaska – Revision 1**. Available from: [http://dec.alaska.gov/spar/perp/docs/ISB-Rev1\(Final-August%202008\).pdf](http://dec.alaska.gov/spar/perp/docs/ISB-Rev1(Final-August%202008).pdf).
- Allen, A.A. 2011. **In-situ Burning Operations during the Deepwater Horizon Oil Spill**. Presentation at OSPR/Chevron Oil Spill Response Technology Workshop, February 2011.
- Allen, A.A. and Ferek, R. 1993. **Advantages and Disadvantages of Burning Spilled Oil**. In: *Proceedings of the 1993 Oil Spill Conference*, March 29-April 1, Tampa, FL. American Petroleum Institute, Washington, DC, U.S., pp. 765-772.
- Aurell, J. and B. Gullett. 2010. **Aerostat Sampling of PCDD/PCDF Emissions from the Gulf Oil Spill In Situ Burns**. *Environ. Sci. Technol.*, 2010, 44(24):9431-9437.
- Blenkinsopp, S.A., G.A. Sergy, K.G. Doe, G.D. Wohlgeschaffen, K. Li, and M.F. Fingas. 1997. **Evaluation of the Toxicity of the Weathered Crude Oil used at the Newfoundland Offshore Burn Experiment (NOBE) and the Resultant Burn Residue**. In: *Proceedings of the Arctic and Marine Oilspill Program (AMOP) Technical Seminar*, No. 20a: 677-684.
- Booher, L. and B. Janke. 1997. **Air Emissions from Petroleum Hydrocarbon Fires during Controlled Burning**. *American Industrial Hygiene Association Journal*, Volume 58, Issue 5, 1997 pages 359-365.
- Brandvik, P.J., J. Fritt-Rasmussen, R. Daniloff, and F. Leirvik. 2010a. **Using a Small Scale Laboratory Burning Cell to Measure Ignitability for In Situ Burning of Oil Spills as a Function of Weathering**. In: *Proceedings of the 33rd Arctic Marine Oil Spill Programme (AMOP) Technical Seminar*. Environment Canada on Environment Contamination and Response, Vol. 2, pp. 755–773.
- Buist, I.A., S.L. Ross, B.K. Trudel, E. Taylor, T.G. Campbell, P.A. Westphal, M.R. Meyers, G.S. Ronzio, A.A. Allen, A.B. Nordvik. 1994. **The Science, Technology, and Effects of Controlled Burning of Oil Spills at Sea**. MSRC Technical Report Series 94-013. Marine Spill Response Corporation, Washington, DC, U.S.
- Buist, I.A., B.K. Trudel, J. Morrison, and D.V. Aurand. 1995. **Laboratory Studies of the Physical Properties of In Situ Burn Residues**. In: *Proceedings of the Arctic and Marine Oilspill Program (AMOP) Technical Seminar*, No. 18, Vol. 2, Environment Canada, Ottawa, ON, Canada, pp. 1027-1051.
- Buist, I., J. McCourt, S. Potter, S. Ross, and K. Trudel. 1999. **In situ burning**. *Pure and Applied Chemistry*. 71(1):43-66.
- Campagna, P.R. and A. Humphrey. 1992. **Air sampling and monitoring at the Kuwait oil well fires**. In: *Proceedings of the Fifteenth Arctic and Marine Oilspill Program (AMOP) Technical Seminar*, June 10-12, Edmonton, AB. Environment Canada, Ottawa, ON, Canada, pp. 575-592.
- Canadian Council of Ministers of the Environment (CCME). 1999. **Canada-Wide Standards for Particulate Matter (PM) and Ozone**. June 5-6, 2000, Quebec City, QB, Canada.
- Daykin, M., G. Sergy, D. Aurand, G. Shigenaka, Z. Wang, and A. Tang. 1994. **Aquatic Toxicity Resulting from In Situ Burning of Oil-On-Water**. In: *Proceedings of the Seventeenth Arctic and Marine Oilspill Program (AMOP) Technical Seminar*, Environment Canada, Ottawa, ON, Canada, pp. 1165-1193.

- Dickins, D.F., P.J. Brandvik, J. Bradford, L-G. Faksness, L. Liberty, and R. Daniloff. 2008. **Svalbard 2006 Experimental Oil Spill Under Ice: Remote Sensing, Oil Weathering Under Arctic Conditions and Assessment of Oil Removal by In-situ Burning**. In: *Proceedings of the 2008 International Oil Spill Conference (IOSC)*, Savannah, GA. American Petroleum Institute, Washington, DC, U.S.
- Dowty, R.J., J.W. Brown, F.N. Stone, J. Lake, and J.L. Lasetar. 1981. **GC-MS Analysis of Volatile Organics from Atmospheres Impacted by the Amoco Cadiz Oil Spill**. In: "Amoco Cadiz: Fates and Effects of the Oil Spill.", *Proc. Int. Symp., Centre Oceanog. de Bretagne*, Brest, France, 19-22 November 1979. Centre Nationale Pour Exploitation des Oceans. Paris, France, pp. 13-22.
- European Commission. 2012. **Air Quality Standards**. Brussels, Belgium: European Commission, 2012. <http://ec.europa.eu/environment/air/quality/standards.htm>.
- Evans, D., G. Mulholland, D. Gross, H. Baum, W. Walton, and K. Saito. 1988. **Burning, smoke production, and smoke dispersion from oil spill combustion**. NISTIR 89-4091, (U.S. Dept. of Commerce, National Institute of Standards and Technology), 57 p.
- Evans, D., G. Mulholland, H. Baum, W. Walton, and K. McGrattan. 2001. **In-situ Burning of Oil Spills**. *J. Res. NIST*, 106(1):231-278.
- Faksness, L-G., J. Borseth, T. Baussant, A. Tanberg, A. Ingvarsdottir, A. Altin, and B. Hansen. 2011. **The Effects of Use of Dispersant and In-situ Burning on Arctic Marine Organisms – A Laboratory Study**. Report SINTEF A19803, SINTEF Materials and Applied Chemistry, Trondheim, Norway.
- Ferek, R.I., P.V. Hobbs, J.A. Herring, K.K. Laursen, R.E. Weiss, and R.A. Rasmussen. 1992. **Chemical Composition of Emissions from the Kuwait Oil Fires**. *Jour. Geophys. Research*, v. 97 (DB); p. 14483-14489.
- Fingas, M. 2011. **Soot Production from In-Situ Oil Fires: Literature Review and Calculation of Values from Experimental Spills**. In: *Proceedings of the Thirty-fourth Arctic and Marine Oilspill Program (AMOP) Technical Seminar on Environmental Contamination and Response*. Environment Canada, Ottawa, ON, Canada.
- Fingas, M.F., G. Halley, F. Ackerman, R. Nelson, M. Bissonnette, N. Laroche, P. Lambert, P. Jokuty, K. Li, N. Vanderkooy, W. Halley, G. Warbanski, P.R. Campagna, R.D. Turpin, M.J. Trespalacios, D.F. Dickins, E.J. Tennyson, D.V. Aurand, R. Hiltabrand. 1994. **The Newfoundland Offshore Burn Experiment - NOBE, Experimental Design and Overview**. In: *Proceedings of the 17th Arctic and Marine Oilspill Program (AMOP) Technical Seminar*, Environment Canada, Ottawa, ON, Canada, p. 1053.
- Fingas, M.P., K. Li, F. Ackerman, P.R. Campagna, R.D. Turpin, S.J. Getty, M.F. Soleki, M.J. Trespalacios, J. Pare, M.C. Bissonnette, and E.J. Tennyson. 1993. **Emissions From Mesoscale In-Situ Oil Fires: The Mobile 1991 and 1992 Tests**. In: *Proceedings of the Sixteenth Arctic and Marine Oilspill Program (AMOP) Technical Seminar*, June 7-9, Calgary, AB. Environment Canada, Ottawa, ON, Canada, pp. 749-821.
- Fingas, M.F. and M. Punt, 2000. **In Situ Burning: A Cleanup Technique for Oil Spills on Water**. Environment Canada Special Publication, Environment Canada, Ottawa, ON, Canada, 214 p.
- Fritt-Rasmussen, J., B.E. Ascenius, P.J. Brandvik, A. Villumsen, and E.H. Stenby. 2012. **Composition of in situ burn residue as a function of weathering conditions**. *Mar. Pollut. Bull.*, 67(1-2): 75-81.
- Garo, J., J. Vantelon, J. Souil, and C. Breillat. 2004. **Burning of Weathering and Emulsified Oil Spills**. *Exp. Therm Fluid Science* 28:753-761.
- Garrett, R., C. Guénette, C. Haith, and R. Prince. 2000. **Pyrogenic Polynuclear Aromatic Hydrocarbons in Oil Burn Residues**. *Environ. Sci. Technol.*, 2000, 34(10):1934–1937.
- Fraser, J., I.A. Buist, and J.V. Mullin. 1997. **A Review of the Literature on Soot Production During In Situ Burning of Oil**. In: *Proceedings of the 1997 Arctic and Marine Oilspill Program (AMOP) Technical Seminar*, June 11-13, 1997, Vancouver, BC. Environment Canada, Ottawa, ON, Canada, pp. 1365-1405.
- Guénette, C.C. and R. Wighus. 1996. **In Situ Burning of Crude Oil and Emulsions in Broken Ice**. In: *Proceedings of the Arctic and Marine Oilspill Program (AMOP) Technical Seminar*, 19(2):895-906. Environment Canada, Ottawa, ON, Canada.

- Gulec, I. and D. Holdway. 1999. **The Toxicity of Laboratory Burned Oil to the Amphipod *Allorchestes compressa* and the Snail *Polinices conicus*.** *Spill Sci Tech. Bull.* 5(2):135-139.
- Grimmer, G. H. Brune, G. Dettbarn, J. Jacob, J. Misfield, U. Moh, K-W. Naujack, J. Timm, and R. Wenzel-Hartung. 1991. **Relevance of polynuclear aromatic hydrocarbons as environmental carcinogens.** *Jour. Analyt. Chem.*, Vol. 339:792-795.
- Hyde, L.J., K. Withers, and J.W. Tunnell, Jr. 1999. **Coastal High Marsh Oil Spill Cleanup by Burning: 5-year Evaluation.** In: *Proceedings of the 1999 International Oil Spill Conference (IOSC)*. American Petroleum Institute, Washington, DC, U.S. pp. 1257-1260.
- Laursen, K.K., R.I. Ferek, P.V. Hobbs, and R.A. Rasmussen. 1992. **Emission Factors for Particles, Elemental Carbon, and Trace Gases from the Kuwait Oil Fires.** *Jour. Geophys. Research*, Vol. 97 (D13):14491-14497.
- Li, K., T. Caron, M. Landriault, J.R. Pare, and M. Fingas. 1992. **Measurement of Volatiles, Semivolatiles, and Heavy Metals in an Oil Burn Test.** In: *Proceedings of the Fifteenth Arctic and Marine Oilspill Program (AMOP) Technical Seminar*, June 10-12, Edmonton, AB. Environment Canada, Ottawa, ON, Canada, p. 561-573.
- Lin, Q., I.A. Mendelsohn, K. Carney, N.P. Bryner, and D.W. William. 2002. **Salt Marsh Recovery and Oil Spill Remediation after In Situ Burning: Effects of Water Depth and Burn Duration.** *Environmental Science & Technology*, 36(4):576-581.
- Martinelli, M., A. Luise, E. Tromellini, T. Sauer, J. Neff, G. Douglas. 1995. **The M/C Haven Oil Spill: Environmental Assessment of Exposure Pathways and Resource Injury.** In: *Proceedings of the 1995 Oil Spill Conference*. February 27-March 2, Long Beach, CA. American Petroleum Institute, Washington, DC, U.S., pp. 679-685.
- McGrattan, K., H. Baum, W. Walton, and J. Trelles. 1997. **Smoke Plume Trajectory from In Situ Burning of Crude Oil in Alaska ---Field Experiments and Modeling of Complex Terrain.** National Institute of Standards and Technology (NIST), Gaithersburg, MD, U.S., 127 p.
- Mendelsohn, I. Q. Lin, K. Carney, N. Bryner, and D. Walton. 2000. **Coastal Marsh Recovery and Oil Remediation after in-situ Burning: Effects of Water Depth, Oil and Marsh Type.** Report for National Institute of Standards and Technology (NIST), Gaithersburg, MD, U.S.
- Mendelsohn, I.A., M.W. Hester, and J.W. Pahl. 1995. **Environmental Effects and Effectiveness of In Situ Burning in Wetlands: Considerations for Oil Spill Cleanup.** Draft, 16 June 1995. Louisiana Oil Spill Coordinator's Office, Baton Rouge, LA, U.S., 57 p.
- Menez, J.R., P. Berthov, D. Picart, and C. Riche. 1978. **Impacts of the Oil Spill (Amoco Cadiz) on Human Biology.** *Penn. Ar. Bed.*, 94:367-378.
- Middlebrook, A.M., D.M. Murphy, R. Ahmadov, E.L. Atlas, R. Bahreini, D.R. Blake, J. Brioude, J.A. de Gouw, F.C. Fehsenfeld, G.J. Frost, J.S. Holloway, D.A. Lack, J.M. Langridge, R.A. Lueb, S.A. McKeen, J.F. Meagher, S. Meinardi, J.A. Neuman, J.B. Nowak, D.D. Parrish, J. Peischl, A.E. Perring, I.B. Pollack, J.M. Roberts, T.B. Ryerson, J.P. Schwarz, J.R. Spackman, C. Warneke, and A.R. Ravishankara. 2012. **Air Quality Implications of the Deepwater Horizon Oil Spill.** *Proc Natl Acad Sci U.S.A.* 2012, Jan 5.
- Moller, T.H. 1992. **Recent Experience of Oil Sinking.** In: *Proceedings of the Fifteenth Arctic and Marine Oilspill Program (AMOP) Technical Seminar*, June 10-12, Edmonton, AB. Environment Canada, Ottawa, ON, Canada, pp. 11-14.
- (California) Office of Environmental Health Hazard Assessment (OEHHA). 2008. **Wildfire Smoke: A Guide for Public Health Officials.** California Office of Environmental Health Hazard Assessment, Sacramento, CA, U.S.
- Pahl, J.W., I.A. Mendelsohn, and T.J. Hess. 1999. **Recovery of a Louisiana Coastal Marsh 3 Years after In Situ Burning of a Hydrocarbon Product Spill.** In: *Proceeding of 1999 International Oil Spill Conference (IOSC)*, American Petroleum Institute, Washington, DC, U.S., pp. 1279-1282.
- Politzer, I.R., I.R. DeLeon, and J.L. Lasetar. 1985. **Impact on Human Health of Petroleum in the Marine Environment.** Report prepared for the American Petroleum Institute, Washington, DC, U.S., 162 p.

- Robertson, I. 1991. **Operational examples of in situ burning: Lessons from the burning of two recent diesel spills on the B.C. coast.** In: Proceedings of the Fourteenth Arctic and Marine Oilspill Program Technical Seminar, June 12-14, Vancouver, British Columbia. Environment Canada, Ottawa, ON, Canada. pp. 411-419.
- Schaum, J., M. Cohen, S. Perry, R. Artz, R. Draxler, J. Frithsen, D. Heist, M. Lorber, and L. Phillips. 2010. **Screening Level Assessment of Risks Due to Dioxin Emissions from Burning Oil from the BP Deepwater Horizon Gulf of Mexico Spill.** *Environ. Sci. Technol.* 2010, 44:9383-9389.
- Schwela, D.H., J.G. Goldammer, L.H. Morawska, and O. Simpson (Eds.). 1999. **Health Guidelines for Vegetation Fire Events.** United Nations Environment Programme, Nairobi, World Health Organization, Geneva, World Meteorological Organization, Geneva, Institute of Environmental Epidemiology, WHO Collaborating Centre for Environmental Epidemiology, Ministry of the Environment, Singapore (ISBN 981-04-1460-9).
- Sheppard, E.P., R.A. Wells, and P.E. Georghiou. 1983. **The Mutagenicity of a Prudhoe Bay Crude Oil and its Residues from an Experimental In Situ Burn.** *Env Research*, 30(2):427-442.
- Sheppard, E.P. and P.E. Georghiou. 1981. **The Mutagenicity of Prudhoe Bay Crude Oil and Its Burn Residues.** In: Proceedings of the Fourth Arctic and Marine Oilspill Program Technical Seminar, Environment Canada, Ottawa, ON, Canada, pp. 251-280.
- S.L. Ross Environmental Research, Ltd. (SL Ross). 1998. **Identification of Oils that Produce Non-Buoyant In Situ Burning Residues and Methods for their Recovery.** American Petroleum Institute and the Texas General Land Office, Washington, DC, U.S., 50 p.
- S.L. Ross Environmental Research Ltd. (SL Ross), DF Dickins Associates, LLC (DF Dickins), Envision Planning Solutions, Inc. 2010. **Beaufort Sea Oil Spills State of Knowledge Review and Identification of Key Issues.** Environmental Studies Research Finds, No. 177, Calgary, AB, Canada, 126 p.
- U.S. Environmental Protection Agency (U.S. EPA). 1999. **Air Quality Index Reporting: Final Rule.** U.S. Environmental Protection Agency, Washington, DC, U.S., Federal Register. 64(149):42530-42549.
- U.S. Environmental Protection Agency (U.S. EPA). 2012. **National Ambient Air Quality Standards (NAAQS).** U.S. Environmental Protection Agency, Washington, DC, U.S. <http://www.epa.gov/air/criteria.html>.
- Walton, D., W. Tilley, J. McElroy, and E. Tennyson. 1994. **Smoke Measurements using a Tethered Miniblimp at the Newfoundland Offshore Oil Burn Experiment.** In: *Proceedings of the 17th Arctic and Marine Oilspill Program (AMOP) Technical Seminar.* Environment Canada, Ottawa, ON, Canada.
- Walton, W.D., K.B. McGrattan, and J.V. Mullin. 1996. **ALOFT-PCL: A Smoke Plume Trajectory Model for Personal Computers.** In: *Proceedings of the 1996 Arctic and Marine Oilspill Program (AMOP) Technical Seminar*, June 12-14, 1996, Calgary, AB. Environment Canada, Ottawa, ON, Canada, pp. 987-997.
- World Health Organization (WHO). 2006. **Air Quality Guidelines Global Update 2005.** World Health Organization, Copenhagen, Denmark.

CHAPTER 9. RISK EVALUATION OF THE ACCEPTABILITY OF BURNING SPILLED OIL

9.1 Objective

During the initial stages of a marine oil spill a decision must be made as to whether or not burning presents acceptable risks to the environment and to human health and safety. This chapter examines the important issues associated with the burn/no-burn decision and evaluates situations in which in situ burning can be considered to be a safe and ecologically sound countermeasures technique. The risks associated to human health from burning are discussed in **Section 9.4** and ecological risks in **Section 9.5**. Implications for decision-making are discussed in **Section 9.6**.

9.2 Description of Assumptions Supporting Risk Evaluation

This evaluation is based on the following assumptions:

- Crude oil spilled has a composition similar to Prudhoe Bay, South Louisiana, or Kuwait crude. Properties of these crudes are given in **Table 3-1** and reproduced in **Table 9-1**.
- Burning is effective in quickly removing at least 75% of the oil targeted for burning.
- Offshore waters that are key breeding or migrating areas need to be protected.
- Nearshore spills are adjacent to shoreline and on-shore resources that are potentially impacted by a burn/no-burn decision.
- The type and abundance of shoreline resources are critical to the burn/no-burn decision.
- Nearshore and estuarine areas possess a greater diversity of habitats and larger numbers of species and populations than found in offshore environments.
- Nearshore areas include human exposure points.
- Estuarine waters are considered to be habitats sensitive to oil, and contain economically important species.

9.3 Chemical and Physical Properties of Oil and Combustion Products

9.3.1 Crude Oil Characteristics

Crude oil is a mixture of thousands of specific hydrocarbon compounds ranging from highly volatile liquids to near-solid tars. **Chapter 3** summarizes the key characteristics of petroleum oil that affect oil spill behaviour and in situ burning. Suffice to emphasise here that crude oils vary widely. Light crudes contain larger percentages of the low boiling, lower molecular weight (LMW) hydrocarbons than do heavy crudes. Heavy crudes have higher boiling points, viscosities, and specific gravity than lighter crudes. The present discussion of risk relates to light and medium density crude oils similar in properties to those described in **Table 9-1**.

Table 9-1: Chemical Composition of Three Crude Oils*			
Characteristics or Component	Prudhoe Bay	South Louisiana	Kuwait
API Gravity	27.8	34.5	31.4
Sulfur (wt. %)	0.94	0.25	2.44
Nitrogen (wt. %)	0.23	0.69	0.14
Nickel (ppm, mg/kg)	10	2.2	7.7
20°-205°C Boiling Point Fraction (wt. %)			
Alkanes	12.5	8.8	16.2
Cycloalkanes	7.4	7.7	4.1
Aromatic Hydrocarbons	3.2	2.1	2.4
Above 205°C Boiling Point Fraction (wt. %)			
n-Alkanes (C11-C32 plus)	5.8	5.2	4.7
Isoalkanes	-	14.0	13.2
Cycloalkanes	28.5	37.7	16.2
Aromatic Hydrocarbons	25.0	16.5	21.9
* From: World Health Organization. 1989.			

9.3.2 Oil Spill Behaviour

The behaviour and weathering of spilled oil are important considerations in deciding whether to leave the oil alone or whether to ignite and burn it. The behaviour of spilled oil includes the following key processes: advection, evaporation, spreading, emulsification, dispersion and dissolution. Please refer again to **Chapter 3** for a brief description of these processes and their importance to the in situ burning process.

9.3.3 Chemical Properties of Crude Oil Combustion Products

As discussed in the previous chapter, the combustion products of crude oil include heat, gases, particulates, and residue. The heat generated is mostly directed upward and away from the burn site, and little heat is absorbed by the water. The smoke plume consists of particles and gases. The gases include CO₂, CO, NO, NO_x, and SO₂.

Particulates typically represent two to twenty percent of the mass of burned crude. Polynuclear aromatic hydrocarbons, or PAHs, are both present in crude and are produced by high temperature and oxygen-poor combustion of oil, and would likely be emitted from burning crudes. The majority of PAHs are generally associated with particulates, but represent a small fraction of the total amount of particulate matter associated with combustion.

Several air sampling programmes were conducted following the Gulf War in 1991. The results of these programmes and other studies (Evans *et al.*, 1989; Allen & Ferek, 1993; Benner *et al.*, 1991) have been analyzed and used here to estimate emissions for an in situ burn expressed as emission factors (kilograms chemical per kilograms of oil burned). The results are presented below in **Table 9-2**.

Table 9-2: Emission Factors for Airborne Chemicals from an In Situ Burn	
Emitted Chemical	Emission Factor (kg chemical/kg burned)
SO ₂	0.02
NO _x	0.0061
CO ₂	2.7
CO	0.00175
VOCS	0.00028
PAHs	0.000004
Total Particulates	0.1

The above table was developed as follows: Where there was agreement among references for a particular emission factor, that factor was used. When there was little agreement for a value, the factor was modified according to the general consensus of what is currently understood about emissions from these kinds of fires and by weighing the relevant comments about order of magnitude emissions from these events. For instance, Allen & Ferek (1993) suggest that the NO_x emission factor is 0.00061 kg/kg oil burned, but other references imply an order of magnitude increase in NO_x emissions under some conditions. The value used for NO_x emission factor, 0.0061 kg/kg, reflects the general order of magnitude recommendations from available literature, and is conservative (higher emission rate). Best engineering judgements were also made for CO and VOCs emission factors.

The emission rate thus derived for SO₂, NO_x, CO, CO₂ and particulates are used in computer dispersion modeling in this evaluation to determine the change of concentration of pollutants as a function of distance from the burn site. This modeling analysis is described in Buist *et al.* (1994).

9.4 Human Health Risk Evaluation

9.4.1 Introduction

This section evaluates the potential health risks to members of the public from burning oil in a nearshore marine environment. Burning in an offshore environment is not evaluated because public health risks would generally be negligible. Nor are potential risks to spill response personnel addressed because responders are assumed to be properly trained and equipped to

minimise hazardous exposures. This human health risk evaluation describes the chief pathways by which humans could be exposed to chemicals produced during burning of oil in a nearshore environment, identifies the chemicals of concern for adverse health effects, and estimates carcinogenic and noncarcinogenic risks associated with exposures to those chemicals. Health risks are estimated using conservative (health-protective) assumptions regarding chemical concentrations, toxicity, and exposure conditions so that potential risk will not be underestimated.

It will be shown in the following analysis that human health effects due to toxicity or carcinogenicity of chemicals of concern in smoke from the burn are low and should not affect decisions on implementing burning as a spill countermeasure. However, people within 1200 and 2500-m of the burn site could be exposed to concentrations of particulate matter that exceed U.S. national or state ambient air quality standards by factors of about 1.5 to 2 depending on the size of the burn and meteorological conditions (see smoke plume model in Buist *et al.*,1994). These exceedances would be temporary and transient, and would not represent a continuing violation of the PM standard.

9.4.2 Human Exposure Pathways

The chief pathways by which humans may be exposed to chemicals of concern during burning of an oil spill are:

1. Inhalation of airborne contaminants in particulate matter (soot); and
2. Incidental ingestion of soot or soot-contaminated soil.

Other possible exposure routes are dermal absorption of chemicals from skin contact with soot and ingestion of contaminated seafood. Dermal absorption of chemicals adhered to soot is expected to be negligible, because organic compounds bind tightly to soot (carbons), and they are not likely to partition to skin in significant amounts, especially under short-term exposure conditions as would occur during an oil burn. The dermal absorption pathway is therefore not evaluated quantitatively in the risk assessment. The seafood ingestion pathway is considered negligible for the burn scenario because burning considerably reduces the quantity of oil that could result in contamination of aquatic species compared with other control measures. Therefore this pathway is not important in assessing the human health risks associated with burning the spill.

Direct human contact with the burn residue is not evaluated because the opportunity for exposure of the public is low.

9.4.3 Chemicals of Concern for Health Risk Assessment

Chemicals of concern for human health risk assessment are those chemicals released to the environment that, at certain exposure levels, could have significant adverse health effects. The greatest concern in a burn scenario is for exposure to contaminants in the smoke plume. Therefore, this section focuses on chemicals of concern in the plume to which the general human population might be exposed.

9.4.3.1 Constituents of Crude Oil

Crude oil is a complex mixture of thousands of organic compounds, most of which are saturated hydrocarbons or aromatics. **Table 9-3** lists concentrations of C₁₂ to C₂₄ straight-chain

alkanes (n-paraffins) and aromatic hydrocarbons in the API reference oils (Kuwait Crude and Louisiana Crude) and

Compound	Kuwait Crude ¹	Louisiana Crude ¹	Alberta Sweet Crude ²
Total C12-Cz4 n-paraffins	40,000	39,800	
Benzenes	80,000	92,000	
Naphthalene	400	400	
1-Methylnaphthalene	500	800	
2-Methylnaphthalene	700	900	
Dimethylnaphthalenes	2,000	3,600	
Trimethylnaphthalenes	1,900	2,400	
Biphenyls	<100	<100	
Acenaphthylene			13
Acenaphthene			57
Anthracene			11
Fluorenes	<100	200	209
Phenanthrene	26	70	150
1-Methylphenantbrene		111	
2-Methylphenantbrene	89	144	
Fluoranthene	2.9	5.0	6
Pyrene	4.5	3.5	17
1-Methylpyrene			39
Benzo(a)anthracene	2.3	1.7	
Chrysene	6.9	17.56	30
Triphenylene	2.8	10	30
Benzo(ghi)fluoranthene	<1		
Benzo(b)fluoranthene	<1	<0.5	4
Benzo(j)fluoranthene	<1	<0.9	
Benzo(k)fluoranthene	<1	<1.3	
Benzo(a)pyrene	2.8	0.75	
Benzo(e)pyrene	0.5	2.5	5
Perylene	<0.1	34.8	
Benzo(ghi)perylene	<1	1.6	
2-Methylcholantbrene			3

¹ From Neff & Anderson, 1981.
² From Benner, *et al.*, 1991

in Alberta Sweet Crude (PAHs only). Benzene and alkyl substituted benzenes are present in the crude oil at concentrations of 8 to 9 percent, and naphthalenes are present at concentrations of 0.5 to 0.8 percent. PAHs, many of which are known to be toxic or carcinogenic, are present in much lower concentrations; total PAHs constitute less than 0.1 percent of the total hydrocarbons in these oils.

Table 9-3 does not include the lower molecular weight saturated hydrocarbons (C_1 to C_{11}) that are present in crude oil. Pentanes through decanes dominate in this group. These compounds are volatile and would be quickly lost from oil slicks during spills.

Compounds containing sulfur and nitrogen, and metals such as vanadium, nickel, and zinc are also present in low concentrations ranging from less than 10-ppm to several hundred ppm depending on the metal and the type of crude. The metals occur primarily as large, high molecular weight, stable organometallic complexes that are not readily soluble or biologically available. Other trace metals are also found in crude oil, generally in concentrations much less than 1 ppm.

9.4.3.2 Constituents of Concern during Burning

Only some of the constituents of crude oil are known to be carcinogenic or toxic at low dosages. The following paragraphs describe which chemicals are of concern for risk assessment and which are not.

9.4.3.2.1 Volatile Organic Compounds (VOCs):

Many of the low molecular weight constituents that are potentially hazardous, such as benzene, toluene, n-hexane, and naphthalenes, are readily volatilized and combusted during burning. These compounds are normally released to air during an oil spill and can contribute to acute health effects in humans (such as nausea and headache) if exposure to high concentrations occurs. Since the concentrations of these compounds in the air are much reduced by burning (Fingas *et al.*, 1993), burning will reduce risk of exposure of shoreline receptors to potentially hazardous concentrations of volatile organics from a single slick. In the case of a large, ongoing spill, the use of burning may not eliminate VOCs from the air. Measurements at the DWH incident during in situ burning operations showed that the largest source of primary air emissions was evaporating hydrocarbons (about 8% of the oil reaching the water surface) with about 4% of the oil burned (being about 6% of the total oil released) ending up as soot particles in the air (Middlebrook *et al.*, 2012).

9.4.3.2.2 Metals:

Metals are present in crude oil; however they occur only in low concentrations and are generally bound up in organometallic complexes that are largely retained in the burn residue (to which exposures are expected to be minimal). For this reason, metals are not considered chemicals of concern during in situ burning and no risk assessment has been conducted here.

9.4.3.2.3 PAHs:

The primary chemicals of concern in the smoke plume are the toxic and carcinogenic PAHs. Some of the PAHs in the crude oil are not destroyed during burning, and some may be created during incomplete combustion. **Table 9-4** lists PAHs in particulates and burn residue measured in a laboratory scale burn of Alberta Sweet Crude (Benner *et al.*, 1990). The PAHs are grouped as carcinogenic, noncarcinogenic (toxic), and other. "Other PAHs" are PAHs that either have

not been tested, have no observed adverse effects, or for which data are insufficient to demonstrate toxicity. These "other PAHs" are not evaluated in the human health risk assessment.

Table 9-4: Concentrations of Carcinogenic and Noncarcinogenic PAHs (Vapour and Particulate) Produced by Combustion of Alberta Sweet Crude Oil ¹ (µg of PAH/g of sample)					
Crude PAHs Oil	Minimum	Soot ²		Residue ²	
PAHs	Crude Oil	Minimum	Maximum	Minimum	Maximum
Carcinogens³					
benzo(a)anthracene		155	260		
chrysene/triphenylene	30	78	260	24	34
benzofluoranthenes ⁴		260	430		
benzo(a)pyrene		190	310	3	4
2-methylcholanthrene	3			3	3
indeno(1,2,3-cd)pyrene		120	200		
Sub-Totals		803	1460	30	41
Non-Carcinogens⁵					
acenaphthene	57			10	15
fluorene		59		35	47
2-methylfluorene	150			110	160
anthracene	11	210	440	13	19
fluoranthene	6	580	950	11	22
pyrene	17	610	1070	25	30
benzo(a)fluorene		70	70		
benzo(b)fluorene		70	70		
1-methylpyrene	39	56	56	16	19
Sub-Totals	339	159	2656	220	312
Other⁶					
acenaphthylene	13	1740	1740	26	54
preanthrene	150	910	1820	120	140
3-m.ethylphenanthrene		16	36		
2-methylphenanthrene		21	40		
1-methylphenanthrene		12	33		
dimethylphenanthrenes	500			520	520
acephenanthrylene		330	520		
perylene		5	56		
benzo(e)pyrene	5	90	140	6	6
benzo(ghi)perylene		120	250	2	2
coronene		45	252		
Sub-Totals	1038	3289	4887	1004	1052
TOTALS	1410	5688	9003	1254	1405

Table 9-4: Concentrations of Carcinogenic and Noncarcinogenic PAHs (Vapour and Particulate) Produced by Combustion of Alberta Sweet Crude Oil ¹ (µg of PAH/g of sample)					
Crude PAHs Oil	Minimum	Soot ²		Residue ²	
PAHs	Crude Oil	Minimum	Maximum	Minimum	Maximum
¹ From laboratory-scale experiments; Brenner <i>et al.</i> , 1990. ² Thickness of oil slicks ranged from 2-mm to 30-mm. ³ Based on identification of carcinogenicity by U.S. EPA (IRIS) or NAS, 1972. ⁴ Benzofluoranthenes are grouped together as carcinogens, although some isomers are not known to be carcinogenic (such as benzo(ghi)fluoranthene). ⁵ Based on U.S. EPA (IRIS) and assumption that methylated and benzo-compounds are also toxic. ⁶ No or insufficient evidence of carcinogenicity or toxicity.					

The relative proportions of the PAHs shown in **Table 9-4** (derived from Benner *et al.*, 1990) are comparable to those measured in mesoscale experiments conducted near Mobile, Alabama (Fingas *et al.*, 1993), but a greater number of individual PAHs were identified in the laboratory experiments. Acenaphthene and phenanthrene were detected in the greatest concentrations in both the laboratory and mesoscale experiments. Toxic or carcinogenic effects for these compounds have not been established. Pyrene, fluoranthene, and other noncarcinogenic PAHs with known non-cancer effects were detected in relatively low concentrations. Carcinogenic PAHs were detected in still lower concentrations in both the laboratory and mesoscale experiments. Benzo(a)pyrene and benzofluoranthenes were detected in both series; additional carcinogenic PAHs were identified in the laboratory experiments. Therefore, the data in **Table 9-4** are considered to be an accurate representation of PAH concentrations in smoke from an oil burn.

9.4.3.2.4 Inorganic Air Pollutants:

NO_x, SO₂, and PM (particulate matter) that are emitted during an oil burn can be respiratory irritants and can aggravate existing respiratory or cardiac ailments in humans. There is also some evidence that they may enhance carcinogenic effects of PAHs (see **Section 9.4.4**). However, it appears that ground-level concentrations of NO_x and SO₂ are not likely to exceed short-term air quality criteria within the area of plume impact. **Table 9-5** lists modeled maximum ground-level air concentrations of these pollutants from a hypothetical burn (see Buist *et al.*, 1994) and compares them with U.S. NAAQS and the most limiting standard. The hypothetical burn scenario used in modeling assumes that 1000 barrels of oil in a 30-m diameter pool are ignited as a single event, rather than being separated by booms into smaller pools for controlled burning (such as would be the case for burning oil on melt pools). Air dispersion modeling for a large single event is likely to predict greater emissions impacts at greater distances from the source than would be predicted for several smaller sources. As shown in **Table 9-5**, modeled concentrations of particulates (PM) only exceed national or state criteria for short-term air concentrations for distances between 1200 and 4500-m from the burn. This is consistent with the findings of Fingas *et al.* (1993), where it was concluded that ground-level air concentrations of combustion gases, including SO₂, were not of concern during meso-scale oil burn tests.

Table 9-5: Modeled Maximum 24-Hour Air Concentrations of Criteria Pollutants Compared with Ambient Standards, $\mu\text{g}/\text{m}^3$			
Constituent	Modeled 24-hr Maximum Concentration in Plume ¹	U.S. National Ambient Air Standard	Most Limiting State Standard
PM10	323 806 (1-hr)	150 (24-hr)	50 (annual)
CO	10 (8-hr)	10,000 (8-hr)	10,000 (8-hr)
NO _x	120	100 (annual)	100 (annual) 1,300 (3-hr)
SO ₂	65	365 (24-hr)	365 (24-hr)

¹ 24-hour maximum, except where noted. Results of modelling a 1000-barrel burn using emission factors estimated from the Kuwait oil field fires showed maximum concentrations at 1540-m downwind of the source. See Buist *et al.*, 1994 for modelling approach and assumptions.

9.4.3.2.5 Dioxins:

The U.S. EPA used the sample data on dioxin concentrations in smoke plumes (Aurell & Gullett, 2010) from the DWH burn operations in computer models to estimate dioxin exposures to workers near the burns and residents at further distances (Schaum *et al.*, 2010). The incremental cancer risks were extremely low and far below the range that EPA considers to be of concern. Incremental risks from the DWH burns were estimated to be: 6×10^{-8} (6 chances in 100 million) for workers, 6×10^{-12} (6 chances in a trillion) for residents and 6×10^{-8} for fish consumption. U.S. EPA usually considers the risk range 10^{-6} to 10^{-4} (1 chance in a million to 1 chance in one hundred thousand) to be where additional actions should be considered.

In conclusion, only the PAHs in smoke are considered to be chemicals of concern from the perspective of risks to human health. The specific PAHs of concern for quantitative risk assessment are shown in [Table 9-4](#).

9.4.4 Toxicity Assessment

This section briefly describes the toxic and carcinogenic effects of PAHs and presents toxicity factors established by the U.S. Environmental Protection Agency (U.S. EPA) that are used to estimate carcinogenic risk and non-carcinogenic hazards. A brief discussion of the effects on PAHs of inorganic air pollutants and sunlight is also included.

9.4.4.1 Health Effects of PAHs

9.4.4.1.1 Noncarcinogenic PAHs:

The PAHs acenaphthene, fluoranthene, fluorene, and pyrene have been shown to affect the liver, spleen, kidney, and blood in laboratory mice. Pyrene has adverse effects at somewhat lower doses than the others, and is therefore the most conservative (health-protective) measure of potential toxicity. The lowest dose of pyrene that elicited toxic effects in laboratory animals was 125 mg/kg-day (U.S. EPA IRIS). No effect was seen at 75 mg/kg-day. This dose is many

thousands of times higher than those to which the public would be exposed during burning of an oil spill. The maximum dose estimated later in [Table 9-9](#) for human exposures is 0.02 mg/kg-day (child accidentally eating soot for 5 days). This dose would not be expected to have adverse effects. Furthermore, the acute toxicity of pure PAHs appears low when administered orally or dermally to rats or mice (U.S. EPA IRIS).

9.4.4.1.2 Carcinogenic PAHs:

EPA has identified the following PAHs as carcinogenic, based primarily on experimental evidence in animals: benzo(a)anthracene, benzo(a)pyrene, benzo(b)fluoranthene, benzo(k)fluoranthene, chrysene, indeno(1,2,3-cd)perylene, and dibenzo(a,h)anthracene. Other carcinogenic PAHs listed in [Table 9-4](#) are identified as carcinogenic by NAS (1972). Benzo(a)pyrene (BaP) is one of the most carcinogenic of the PAHs.

In laboratory studies, ingestion and inhalation of BaP by mice, rats and hamsters, and dermal and subcutaneous administration of BaP to these animals have produced a variety of tumours in the kidney, stomach, lungs, respiratory tract, and skin. Tumours have also been produced in some but not all studies performed in primates. Most tumours occur at the point of contact.

The carcinogenicity of some PAHs in humans is supported by evidence from workers exposed for many years to soot, other products of coal combustion and gasification, lubricating oils, and cigarette smoke, all of which contain significant quantities of carcinogenic PAHs. For example, a number of studies and observations from the late 1700s through the mid-1900s show increased cancers of the skin and scrotum among English chimney sweeps exposed since childhood to coal soot, industrial workers whose clothing was saturated with lubricating oils, and workers routinely exposed to pitch, tar, and asphalt. Past unhygienic working conditions contributed to these hazardous exposures. Lung cancer has also been associated with occupational exposures at coal gasification plants and coke ovens and with cigarette smoking.

It should be noted that the doses given to laboratory animals are many thousands of times higher than conservative estimates of doses from exposure to smoke from an oil burn. For example, daily doses given to laboratory animals in the experiments used to quantify the cancer potency of BaP ranged from approximately 2×10^{-2} to 1 milligram BaP per kilogram body weight per day (mg/kg-day) (U.S. EPA IRIS). These high doses can be compared with the much lower dose of 6.5×10^{-6} mg/kg-day total carcinogenic PAHs estimated for smoke inhalation and particulate ingestion from oil burning (this value is the sum of doses shown later in [Table 9-8](#)). These low doses in humans are not likely to produce a measurable increase in cancer incidence (see risk evaluation in [Section 9.4.5](#)). Furthermore, exposures in the occupations listed above far exceed exposures that would occur to a smoke plume from an oil burn.

9.4.4.1.3 Effects of Other Air Pollutants and Sunlight on PAHs:

There is some epidemiological and experimental evidence to suggest that exposure to certain inorganic air pollutants, such as SO₂, NO_x and ozone, may potentiate the carcinogenic effects of PAHs. It is possible that irritation of respiratory passages by inorganic air pollutants increases the sensitivity of respiratory tissues to carcinogenic PAHs. Some supporting evidence from laboratory experiments is available. For example, in one experiment (Laskin *et al.*, 1970, as reported in NAS, 1972), simultaneous exposure to SO₂ and BaP appeared to enhance the tumour rate in rats but not in hamsters. Exposure was to 10-ppm SO₂ for 6 hours/day plus 10 mg/m³ BaP and 3.5-ppm SO₂ for 1 hour/day. These concentrations are considerably higher than those to which humans would be exposed at the maximum concentration location, 1500 to

2000-m from a burn site, and the exposure conditions do not include weathering, photo oxidation, and other processes that degrade chemicals in a smoke plume. Therefore, the experimental conditions are not representative of human exposures in the environment and, because combustion gases such as SO₂ are not likely to be of concern at a distance of a few thousand metres from the burn, this possible potentiating effect can be neglected.

Furthermore, the possible potentiating effects of other air pollutants may be offset by natural degradation of PAHs, especially as a result of photo-oxidation. In some experiments, exposure for about 40-minutes to light equivalent to one-fourth that of noon sunlight caused 35 to 65 percent loss of BaP in smoke samples (Tebbens *et al.*, 1966; and Thomas *et al.*, 1968; as reported in NAS, 1972). Other experiments have provided comparable results. Half-lives of PAHs in air may therefore be on the order of hours. Some experiments have shown that the carcinogenic potency of a crude mixture is lower than expected when the potency of the known carcinogenic constituents is considered (Falk *et al.*, 1964). It appears that the presence of a related but less potent compound can inhibit the activity of the more potent compound.

Anticarcinogenic as well as co-carcinogenic mechanisms are both likely to occur. Therefore, the potentiating and degradation effects of other chemicals and environmental factors are likely to offset each other and are neglected in estimating potential risk.

9.4.4.2 Toxicity Factors

The EPA has established toxicity factors that are used to provide a quantitative estimate of health risk from exposure to chemicals in the environment. Toxicity factors for carcinogenic effects are called slope factors (SFs) for oral and dermal risk assessment. Unit risk factors (URFs) are toxicity factors for assessing inhalation cancer risk. Oral and dermal non-cancer toxic effects are evaluated using reference doses (RfDs).

Toxicity factors are derived primarily from laboratory studies in animals. There is considerable uncertainty in extrapolating from animal studies to humans because of differences in the doses to which experimental animals and humans are exposed and because of the considerable variability in responses to chemicals among different species. Where possible laboratory experiments are conducted in susceptible species; humans may be more resistant to the effects of the chemical than the animals used in many experiments. Therefore, SFs and RfDs are conservative (health-protective) measures of potential carcinogenicity or toxicity in humans.

SFs and RfDs for PAHs are shown in Table 9-6. Their derivation and application in risk assessment are described in more detail below.

Table 9-6: Toxicity Factors for PAHs					
Compound	Slope Factor (mg/kg-day) ¹ Oral	Inhalation Unit Risk Factor (ug/m ³) ⁻¹	Reference Dose (mg/kg-day)		
			Oral		Inhalation
			Sub chronic	Chronic	
Benzo(a)pyrene ⁽¹⁾	7.3E+0	⁽²⁾ 1.1E-03	NA	NA	NA
Pyrene			3E-1	3E-2	NA
Acenaphthene			6E-1	6E-2	NA
Anthracene			3E+0	3E-1	NA

Fluoranthene			4E-1	4E-2	NA
Fluorene			4E-1	4E-2	NA
Sources:	U.S. EPA, 1993. Health Effects Assessment Summary Tables (HEAST) (sub chronic RfDs). U.S. EPA, Integrated Risk Information System (IRIS). On-line database.				
(1)	SF has been established only for benzo(a)pyrene. Relative carcinogenicity of other PAHs is shown in Table 8-7 .				
(2)	Provisional value from State of California also used by U.S. EPA				
NA	Not Available				

9.4.4.2.1 Slope Factors for PAHs:

The SF describes a dose-response relationship between the level of exposure to a carcinogen and the probability of getting cancer from the exposure. The SF has units of risk per mg chemical/kg body weight per day, usually expressed as (mg/kg-day). The SF is multiplied by the lifetime average daily intake of a chemical, expressed as mg chemical/kg-day, to yield an estimate of lifetime excess cancer risk.

In establishing SFs for carcinogens, the EPA has taken a conservative (health-protective) approach in assuming: (1) that exposure even to very low doses of a carcinogen has the potential to increase the risk of cancer (i.e., it is assumed that there is no threshold dose below which a response, however small, does not occur); and (2) that responses to high doses given to susceptible laboratory animals can be extrapolated to responses to low doses in humans using a simple linear model. Furthermore, the SFs are upper 95th percentile confidence limits of a linear model based on dose response relationship determined in the laboratory. U.S. EPA states that carcinogenic risks estimated using this approach are upper-bound estimates and that actual risks are likely to be lower (U.S. EPA, 1989a) and could be zero.

Using such an approach, U.S. EPA has developed an oral slope factor for benzo(a)pyrene of 7.3 (mg/kg-day). The inhalation slope factor of 6.1 (mg/kg-day)⁻¹ was withdrawn for further review in 1993. For purposes of this risk assessment, the oral slope factor is adopted to assess risk from both oral and inhalation exposures.

Table 9-7 shows the relative carcinogenic potency of other PAHs compared with BaP, which is assigned a relative potency of 1. Other PAHs have lower relative potency. In this risk assessment, the SF for BaP is used for all carcinogenic PAHs identified in the plume (**Table 9-4**). This is a reasonable approach that is not likely to underestimate potential risk because:

- BaP is among the most carcinogenic of the PAHs and therefore its SF overestimates the potency of most other PAHs (see **Table 9-7**).
- Adopting the BaP slope factor for other PAHs that are less carcinogenic helps account for possible increased carcinogenicity of some methylated PAHs and for possible synergistic effects resulting from the presence of other pollutants that may enhance carcinogenicity.

Table 9-7: Relative Potency Estimates for Carcinogenic PAHs	
Compound	Relative Potency

Benzo(a)pyrene	1.0
Benzo(a)anthracene	0.1
Benzo(b)fluoranthene	0.1
Benzo(k)fluoranthene	0.01
Chrysene	0.001
Dibenzo(a,h)anthracene	1.0
Indeno(1,2,3-cd)pyrene	0.1
Source: U.S. EPA, 1993	

The carcinogenic PAHs exert their possible carcinogenic effects by interacting with DNA. This mode of carcinogenic action produces mutations. Children are considered to be more sensitive to the carcinogenic effects of PAHs than adults. As a result, age-dependent adjustment factors (ADAFs) are used to evaluate the increased cancer risk that children may experience.

9.4.4.2.2 Reference Doses for PAHs:

The RfD is a daily dose of a chemical that is considered safe for a lifetime of exposure. The RfD has units of mg chemical / kg body weight per day (mg/kg-day). RfDs are derived for sub chronic exposures (defined by EPA as 2 weeks to 7 years) and for chronic exposures (7 years or more). Sub chronic RfDs are used to evaluate exposure to smoke during an oil burn of several days, whereas chronic RfDs are used to evaluate longer-term exposures of many years to deposited PM. In establishing RfDs for toxic effects, U.S. EPA usually identifies the highest dose that did not cause an adverse effect in laboratory animals and reduces that dose by "uncertainty factors" to account for extrapolating from one species to another, for extrapolating from short-term high doses to long-term low doses, and for the level of confidence in the experimental data. Therefore RfDs are conservative measures of the potential for adverse effects.

In this risk assessment, the toxicity of PAHs with known non-cancer effects identified in the smoke plume is represented by the oral RfD for pyrene. The chronic RfD for pyrene is 3×10^{-2} mg/kg-day and the sub chronic RfD is 3×10^{-1} mg/kg-day (U.S. EPA IRIS). This is a conservative approach because the RfD for pyrene is lower than the RfDs for other noncarcinogenic PAHs (Table 9-6). The oral RfD is adopted to assess both oral and inhalation exposures since no inhalation RfDs for PAHs have been established.

9.4.5 Risk Assessment

This section provides conservative estimates of potential carcinogenic risk and noncarcinogenic hazard from exposure to PAHs in smoke emanating from an oil burn via the inhalation and incidental ingestion exposure routes. The risk assessment shows that, even under highly conservative exposure assumptions, health risks from exposure to carcinogenic and toxic constituents of the plume are so low that they would not be a significant factor in the burn/no-burn decision. However, somewhat elevated concentrations of PM, which can have acute respiratory effects, could occur a few thousand metres from the burn site, depending on size of the burn and meteorological conditions. As such, burning should not be considered if the burn

is to occur close to a populated shore, unless all shoreline residents can be temporarily relocated during the period of the burn.

9.4.5.1 Exposure Assumptions

The risk assessment is based on several assumptions regarding exposure point concentrations and exposure conditions. Conservative assumptions are mostly used so as not to underestimate potential risk. The chief assumptions are outlined below.

- Emergency response workers wear appropriate protective equipment and are not addressed in the risk assessment.
- Benzene and other volatile compounds present in crude oil are evaporated or combusted and are not significant constituents of the smoke plume (see **Section 9.4.3**).
- All particulate matter in the plume is assumed to be respirable.
- PM concentration at the exposure point is 1 mg/m^3 . This is a conservative value based on estimates from mesoscale burns ($\text{PM} < 2 \text{ mg/m}^3$ at 500-m downwind; Walton *et al.*, 1993) and is supported by results of screening-level air modeling described in Buist *et al.* (1994). Results of the air modeling showed a maximum 1-hr PM concentration of $806 \text{ } \mu\text{g/m}^3$ and a maximum 24-hr concentration of $323 \text{ } \mu\text{g/m}^3$ at 1540-m downwind of the burn site. The concentration of 1 mg/m^3 used in this risk assessment probably overstates typical ground-level concentrations to which people would be exposed during a burn lasting several days by a factor of 3 ($1/0.323 \text{ mg/m}^3$) or more, given that smoke from large-scale tests was nearly invisible from the ground at 800-m (one-half mile) (Raloff, 1993) and that most people would be exposed to concentrations significantly lower than the maximums).
- Burning will not be undertaken if population centers or unprotected persons are within 5-km downwind of the burn site (based on "worst-case" exposure conditions predicted involving the SCREEN 2 model in Buist *et al.*, 1994).
- For purposes of calculating PAH intake based on mg PAH per mg PM in air, PAHs measured in smoke, whether in vapour or particulate phase, are assumed to be associated with PM.
- Concentrations of carcinogenic PAHs in smoke ($0.0015 \text{ mg PAHnc/mg PM}$) and of noncarcinogenic PAHs ($0.003 \text{ mg PAHnc/mg PM}$) are based on laboratory experiments using Alberta Sweet Crude, a medium crude oil (see **Table 9-4**). These data are assumed to be representative of smoke emitted from burning most crude oils. These PAH/PM ratios and the resulting estimates of air concentrations of PAHs are highly conservative estimates of exposure concentrations. They are comparable to concentrations measured at less than 100m downwind of mesoscale burns reported in Fingas *et al.* (1993). For example, using the maximum total concentration of PAHs in soot from **Table 9-4** of $9,000 \text{ } \mu\text{g/gm}$, a PM concentration at the exposure point of 1 mg/m^3 , and a conversion factor of $1 \text{ g}/1000 \text{ mg}$ yields a total PAH concentration of $9 \text{ } \mu\text{g/m}^3$ at 500-m. In the 1991 mesoscale burns, ground-level concentrations of total PAH ranged from $10.5 \text{ } \mu\text{g/m}^3$ at 30-m to $3 \text{ } \mu\text{g/m}^3$ at 60-m (Fingas, 1993). Dilution and dispersion would reduce these concentrations significantly at greater distances. A second round of mesoscale tests performed in 1992 measured even lower PAH concentrations than reported for the 1991 tests. Therefore, the concentrations of PAHs used in the risk calculations are considered worst-case and are not likely to be exceeded. Resulting risk estimates are also considered worst-case.
- The potency of known carcinogenic PAHs measured in smoke is represented by the URF for BaP. This approach is likely to overestimate risk (see **Section 9.4.4**).

- The toxicity of known toxic PAHs measured in smoke is represented by the RfD for pyrene. This is a conservative assumptions because pyrene has the lowest RfD (i.e., is the most toxic) of the known toxic PAHs.
- For purposes of this analysis we have assumed that the burns will last 5-days, and concentrations of hazardous materials in the smoke plume will remain constant for 5-days. Therefore, the exposure duration for inhalation is 5 days.
- Long-term PM concentrations in soil are estimated by assuming that respirable particulate deposits in soil at a deposition velocity of 0.003 m/s (U.S. EPA, 1994) and that the deposited particulate mixes within the top 0.02-m of soil (U.S. EPA, 2005). The density of soil is assumed to be 1.5 g/cm³ (or 1500 kg/m³). Given a five-day deposition period, the PAHc concentration in soil is calculated as $(1 \text{ mg/m}^3 \times 0.0015 \times 0.003 \text{ m/s} \times 0.02\text{-m} \times 5\text{-days} \times 86,400 \text{ seconds/day}) / (0.02\text{-m} \times 1500 \text{ kg/m}^3) = 0.065 \text{ mg PAHc/kg soil}$. In large-scale tests, little fallout was apparent at 800-m from the burn site (one-half mile) (Raloff, 1993).

For the purpose of assessing cancer risk, the estimated concentration of PAHc in soil is compared with the U.S. EPA soil screening level for benzo(a)pyrene. The soil screening level is based on residential child and adult daily exposures to benzo(a)pyrene in soil for 30 years. Residents are assumed to ingest and inhale benzo(a)pyrene in soil and absorb benzo(a)pyrene through the skin. The U.S. EPA residential soil screening level is 0.015 mg/kg and is based on the 1 in 1,000,000 lifetime cancer risk.

9.4.5.1.1 Carcinogenic Risk Calculation.

Carcinogenic risks are estimated as the incremental probability (additional risk above the normal rate of getting cancer) of an individual developing cancer over a lifetime as a result of exposure to a carcinogen. For example, an excess cancer risk of 1×10^{-6} (1 in 1 million) means that there is a 1 in 1 million chance of getting cancer from the exposure, and that an individual's overall risk of getting cancer has been increased by 0.000001. This is a very low risk level that could not be measured or detected in individuals or even in large populations.

Cancer risk estimates are usually interpreted within policy guidelines that establish acceptable risk levels. EPA policy, expressed in the National Oil and Hazardous Substances Pollution Contingency Plan (NCP) (40 CFR Part 300) and other guidance documents, states that "For known or suspected carcinogens, acceptable exposure levels are generally concentration levels that represent an excess upper bound lifetime cancer risk to an individual of between 1×10^{-4} and 1×10^{-6} . Measures to restrict exposure are not usually considered warranted unless cancer risk exceeds 1×10^{-4} (1 in 10,000) (U.S. EPA, 1991b).

In the case of deposited particulate in soil, the lifetime cancer risk is the ratio of the calculated soil concentration of PAHc (0.065 mg/kg) divided by the U.S. EPA residential soil screening level (0.015 mg/kg times 1×10^{-6} or 4.3×10^{-6}).

The lifetime cancer risk associated with inhalation of particulate over the five-day burn period is calculated as follows:

$$\text{Cancer risk} = \text{Exposure Concentration} \times \text{URF} \times \text{ADAF} \quad (9-1)$$

where:

- The exposure concentration is the air concentration of PAHc adjusted for exposure duration over a 70-year lifetime, i.e., 70 years ($\mu\text{g}/\text{m}^3$)
- URF is the chemical-specific unit risk factor ($\text{m}^3/\mu\text{g}$)

- ADAF is the age-dependent adjustment factor

The exposure concentration is calculated according to the following formula:

$$\text{Exposure concentration} = \frac{PM \times PAHc/PM \times 1000 \frac{\mu g}{mg} \times ED}{AT}$$

where:

- PM is the particulate matter concentration in air (mg/m³) or soil (mg/mg). The concentration of PM in the plume is assumed to be 1 mg/m³ at the exposure point downwind. The concentration of PM mixed in soil is 0.005 mg PM/mg soil.
- PAHc/PM is the ratio of carcinogenic PAHs to PM (mg/mg). As shown in [Table 8-4](#), this is estimated to be 1460 µg/g, or 0.0015 g/g.
- ED is the exposure duration (days). For this evaluation, a five-day burn is assumed.
- AT is the averaging time, expressed in days, that is used to calculate a daily intake over the exposure duration. For carcinogens, a 70-year lifetime (25,550 days) is used (U.S. EPA, 1989a; 1991a).

If it is assumed that a young child (less than 2 years of age) may inhale PM, an ADAF of 10 is used for assessing lifetime cancer risk from inhalation of PAHc. The calculated exposure concentration of PAHc (2.94 x 10⁻⁴ ug/m³) times the URF for benzo(a)pyrene (1.1 x 10⁻³ m³/ug) x the ADAF (10) is 3.2 x 10⁻⁶.

Risks from inhaling carcinogenic PAHs in the smoke plume and from exposure to carcinogenic PAHs deposited in the soil are summed to yield a total excess cancer risk of 8 x 10⁻⁶ (8 in 1,000,000). The largest contributors to the total risk estimate are residential exposure to particulate in soil. The excess cancer risk estimate is a worst-case estimate that probably overestimates actual risk because it assumes no degradation of PAHs in air or in soil over a 30-year exposure duration (whereas the half-life of PAHs in air may be on the order of hours; see [Section 9.4.4](#)).

The excess cancer risk of 8 in 1,000,000 is within EPA guidelines for acceptable risk levels. In the United States, the overall chance of getting cancer is 1 in 3 (American Cancer Society, 1990). An excess cancer risk of 8 in 1,000,000 would increase the overall rate from 1 in 3 to 1.000008 in 3. This is a very small increase that would not be observable in individuals or in most populations.

9.4.5.2 Noncarcinogenic (Toxic) Hazard Calculation

The potential for adverse noncarcinogenic effects resulting from exposure to a chemical is evaluated by comparing an exposure level or dose with a reference dose (RfD). The resulting ratio is called a Hazard Quotient (HQ). If the Hazard Quotient is 1 or below, there is no cause for concern for noncancer effects. In general, the greater the value of the Hazard Quotient above 1, the greater the level of concern. However, since the HQ does not define dose-response relationships, its numerical value should not be construed as a direct estimate of risk.

To assess the overall potential for noncarcinogenic effects posed by exposure to multiple pathways, the calculated concentration of PAHnc in soil is compared with the U.S. EPA residential screening level for pyrene. If the calculated concentration of PAHnc in soil is less than the residential soil screening level for pyrene, PAHnc deposition in soil would not result in noncancer risk to residents. For the purposes of this report, pyrene is used as a worst-case surrogate to represent the non-cancer effects of PAHs in the smoke plume since pyrene is the most toxic, semi-volatile, non-carcinogenic PAH.

For the purpose of calculating the concentration of PAHnc in soil and air, the PAHnc/PM fraction is assumed to be 0.003 (see [Table 9-4](#)). Using a PAHnc/PM of 0.003 and the equation and assumptions used above to calculate PAHc in soil, the calculated soil concentration of PAHnc is 0.13 mg/kg. This concentration is well below the U.S. EPA residential soil screening level for pyrene (1,700 mg/kg), indicating that PAHnc would not pose a health concern to a resident exposed daily for years.

As discussed above, there are no inhalation RfDs or RfCs for the PAHnc. However, the potential for systemic health effects from inhaling PAHnc in particulate can be evaluated by converting the oral sub chronic RfD for pyrene (0.3 mg/kg/day), assuming that a child inhales 10-m³ of air per day and that the body weight of a child is 15-kg. Converted to an air concentration of pyrene, the calculation is 0.3 mg/kg/day x 15-kg divided by 10 m³ = 0.45 mg/m³. In contrast, the estimated concentration of PAHnc in air is equal to PM x PAHnc/PM or 1 mg/m³ x 0.003 = 0.003 mg/m³. This air concentration is much lower than the calculated air concentration that would be unlikely to produce systemic noncancer effects in a child resident.

9.4.6 Conclusions

The potential cancer risk level and noncarcinogenic hazard index associated with exposure to PAHs in smoke from burning an oil spill are below levels of concern and indicate that adverse health effects from toxic and carcinogenic constituents of smoke are not a significant factor in making a burn/no burn decision. However, it is apparent from observations and from air modeling that somewhat elevated concentrations of particulate matter can occur a few thousand metres from the burn location, depending on site-specific conditions. Exposure to elevated PM concentrations can have acute respiratory effects and exacerbate existing ailments. Therefore precautions may need to be taken to minimise such exposures if a burn is conducted 1000 to 2000-m from a population center. Temporary and transient exceedances of ambient air quality standards could be considered acceptable if burning is conducted for the overall protection of the environment.

9.5 Ecological Risk Evaluation

This section is a qualitative discussion of the relative ecological risks associated with a burn/no burn decision. The purpose is to assess the relative risks from exposure to crude oil and to the toxic components of burn emissions and residue. The first step in conducting the risk evaluation is an exposure assessment, which identifies the ecological groups that are at risk of significant exposure from the burned or unburned spill. This is followed by a discussion of chemicals of concern and the ecological risk evaluation for all ecological groups that are generally at risk from in situ burning.

9.5.1 Exposure Assessment

The various exposure pathways to a crude oil spill for ecological receptors in burned and unburned spills were considered to identify pathways through which organisms might realistically be exposed to significant concentrations of hydrocarbons from a spill. To be complete an exposure pathway requires five basic elements:

- An oil source (i.e., the spill);

- The fate processes and countermeasures that alter the fate of the oil (e.g., no response, in situ burning);
- The environmental transport media (e.g., water, air);
- The exposure points where oil and receptors are present; and
- The contact/intake route (e.g., surface contamination, ingestion, inhalation.)

If any of the elements is missing, the pathway is not complete and exposure of the ecological receptors cannot occur. The source is the means by which the oil is released into the environment (surface and subsea blowouts and batch spills). The fate processes were discussed earlier (**Chapters 3 and 7**) in terms of the "weathering" processes that lead to transfer of oil from the sea-air, sea-ice or ice-air interface (volatization, dissolution, natural dispersion) through natural forces or effect of burning. Potentially complete exposure pathways are identified through the use of a conceptual site model (CSM), a schematic representation of the various exposure pathways from the source (i.e., crude oil spill) through the release mechanisms, secondary sources, and transfer mechanisms to the ecological receptor categories (e.g., plankton, finfish, waterfowl). These CSMs trace the movement of the oil from the primary source (crude oil spill) through the release mechanisms (e.g., spill is burned), to the secondary sources (e.g., burn residue), through the transfer mechanisms (e.g., floats and moves onshore), to the ecological receptors. Tracing the movements of crude oil or its constituents through the other pathways and environments permits evaluation of the many potential exposure pathways. As an example, in the offshore environment during ice-free periods (**Figure 9-1**) exposure of waterfowl and marine mammals to slicks and surface oil are considered "Likely", while exposure of pelagic fin and shellfish is "Unlikely". Exposure of epontic receptors is "Unlikely" because ice is absent. For the Spill Burned case marine mammals and waterfowl are "Possibly" exposed to Burn Gases and Airborne Smoke Particles, but it is "Unlikely" that any receptor will be exposed to heat.

The CSMs for the offshore and nearshore ice-free and ice-infested environments are shown in **Figures 9-1, 9-2, 9-3 and 9-4**). When using the CSMs to assess exposure risks, a number of considerations should be kept in mind, as follows:

- For purposes of this exposure assessment the "nearshore environment" includes the relatively shallow, coastal estuarine, lagoon and open coast marine area where landfast ice is present in winter and where entrained oil or oil stranded on shore and remobilized could reach shallow, nearshore areas.
- The "offshore environment" is the marine environment that is far enough offshore that spilled oil poses little risk to the intertidal habitats and deep enough that offshore benthic habitat is not likely to be exposed. However, in the arctic any offshore spills could contaminate the edge of the polar pack or its underside in the event of a subsea blowout.
- Exposure assessments in the CSMs consider relative quantities of oil or its components in burn and no burn cases.
- Because burning greatly reduces the volume of oil on the sea surface, the probability of a complete exposure pathway is considered to be lower for the burn residue than for slicks of unburned oil.
- Burning preferentially consumes the volatile and soluble fractions of a crude oil spill. Therefore, burning significantly reduces exposure risks from volatile and water-soluble fractions. On the other hand, burning converts a small, but significant proportion of the spill to soot and burn gases that have some hazard potential to nearby wildlife.

- The release mechanisms listed in the CSMs are considered to be the primary processes that determine the fate and movement of spilled oil or constituents through marine habitats.
- It is assumed that in the Spill Not Burned case mechanical containment and recovery activity is deployed, to modest effect.
- The potential for exposure of ecological receptors to oil or petroleum hydrocarbons are described as "Likely", "Possible", or "Unlikely".
- Definitions of certain of the ecological receptors can be clarified as follows:
 - Production refers to primary production by algae and vascular plants.
 - Shellfish refers to all invertebrate biota.
 - Marine birds refer to waterfowl and marine birds.
 - Marine mammals refer to hairy mammals, pinnipeds and cetaceans.
 - Epontic biota is that associated with the water/ice interface.
- The results of the analysis are illustrated in **Figures 9-1** through **9-4**, and are summarized in **Table 9-8**. In summary:
 - In spills in offshore, ice-free environments the slicks produced pose significant risk of exposure to marine birds and mammals and may pose a risk to shorebirds depending on a range of factors. Similarly, slicks may pose a risk to some terrestrial species (e.g., caribou) when they inhabit coastal areas. In-water and benthic receptors are "Possibly" exposed to dissolved and dispersed oil at low concentrations. Similarly marine birds and mammals very near the spill site are "Possibly" exposed to low concentrations of volatile HCs.

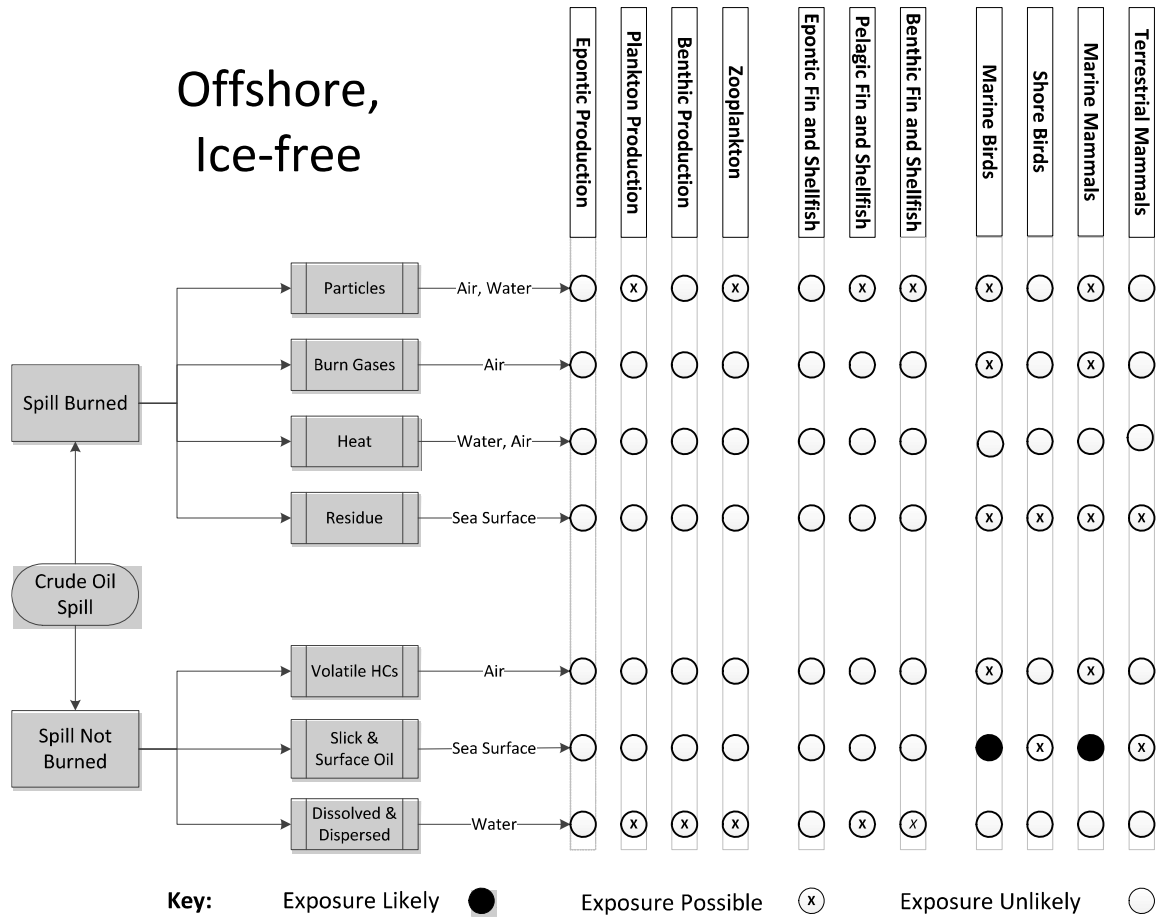

Figure 9-1 Ecological conceptual site model of offshore, ice-free environment.

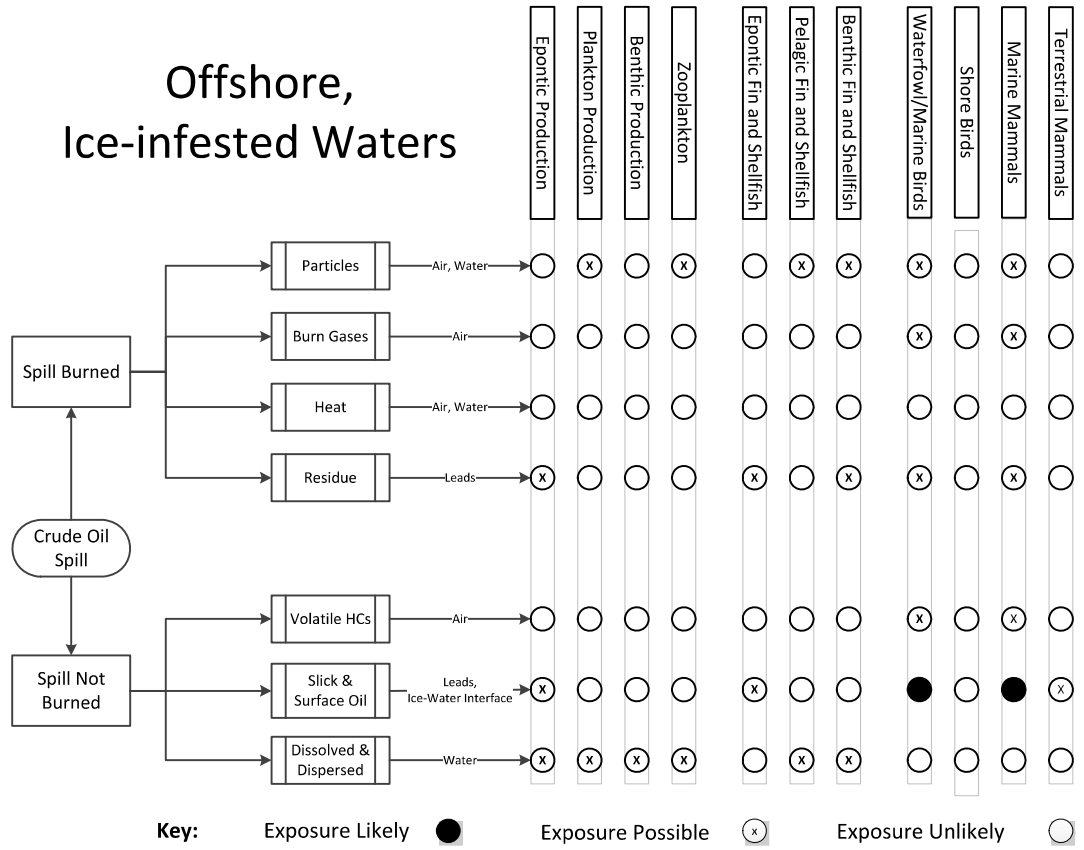

Figure 9-2 Ecological conceptual site model of an ice-affected offshore environment

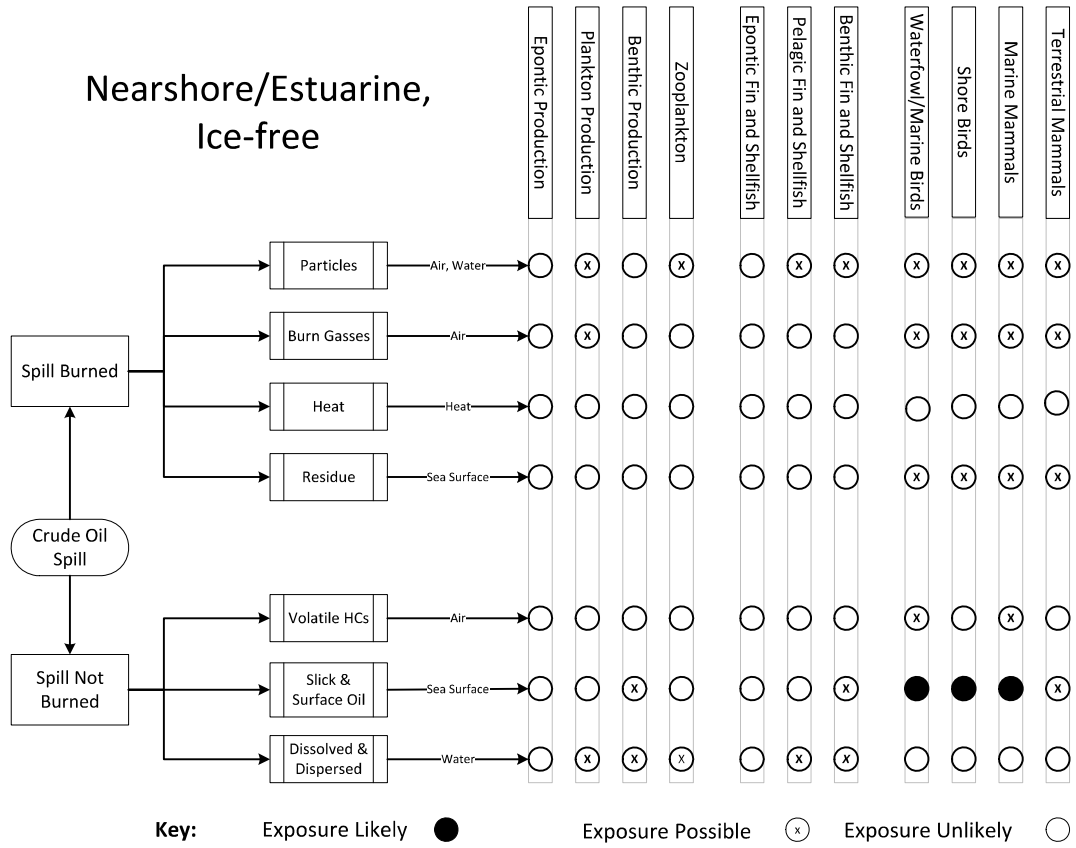

Figure 9-3 Ecological conceptual site model of an ice-free nearshore environment

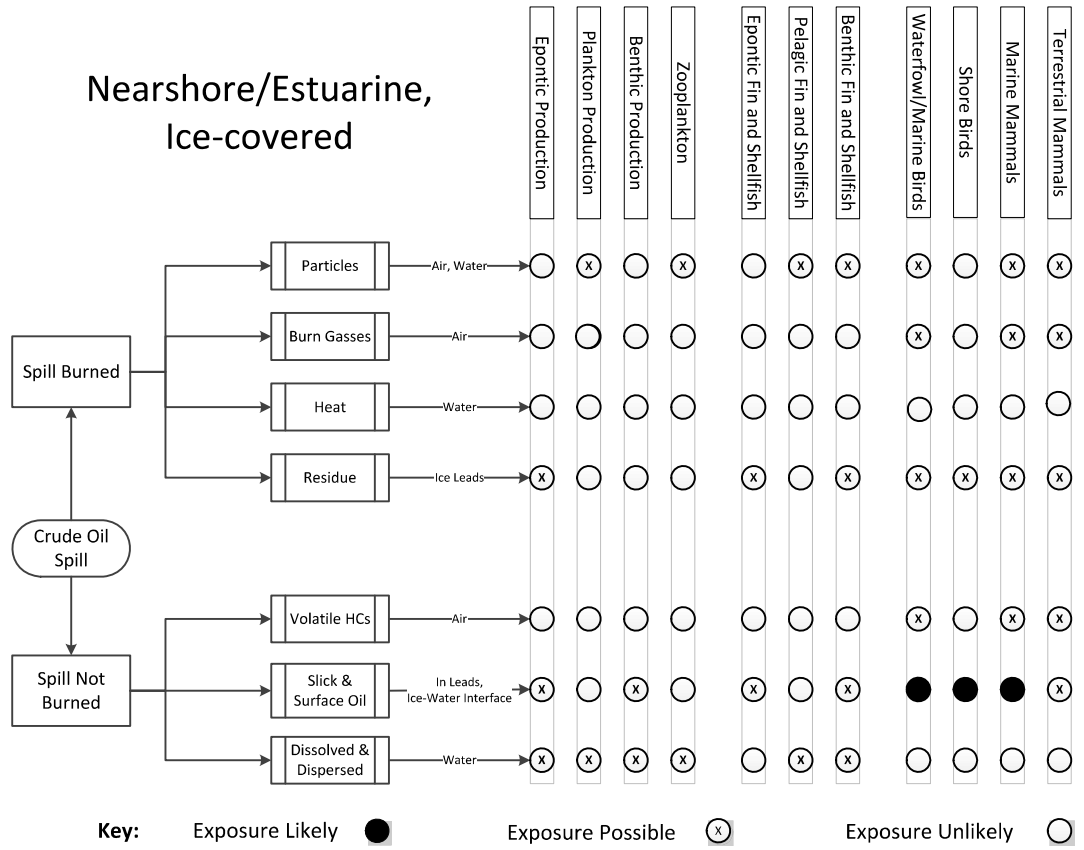

Figure 9-4 Ecological conceptual site model of ice-infested, nearshore environment

Table 9-8: Summary of Conceptual Site Model Assessments

Spill Condition	Offshore Ice-free			Offshore Ice-infested			Nearshore Ice-free			Nearshore Ice-infested			Total		
	L	P	U	L	P	U	L	P	U	L	P	U	L	P	U
Not Burned	2	9	22	2	11	20	3	10	20	3	14	26	10	44	88
Burned	0	12	32	0	13	31	0	17	30	0	17	27	0	59	120
L= Likely P=Possibly U=Unlikely															

- When burning is used to remove some of the oil from an offshore spill, in ice-free environments, the small amount of residue remaining after the fire poses less risk to marine mammals and birds and shorebirds than the unburned slick. Similarly, it poses less risk to terrestrial species (e.g., caribou) that inhabit coastal areas in some regions. There is a possibility that the residue may sink, depending on oil properties, so the risk to the benthic community is increased slightly. Burning does not expose in-water or benthic species to heat beyond the upper few cm of the water column, nor does it **increase the transfer of hydrocarbons to the water column. Marine mammals and birds** very near the burn site may be exposed to low concentrations of burn gases and soot. Some soot will precipitate out of the smoke plume resulting in low level exposures of water column species near the burn to particulate carbon.
- The presence of ice in offshore waters alters the fate of spilled oil and introduces an additional community, the epontic community, which might be at risk from spills. The epontic community is at limited risk from surface spills into leads or broken ice, but would be exposed temporarily to oil surfacing under ice from subsea blowouts. Burning oil on ice or on water or in broken ice is not likely to increase the exposure of the epontic community. Exposures of other communities to unburned oil or burn products are unlikely to be different from exposures in ice-free water.
- In nearshore, ice-free environments unburned slicks from spills pose risks to the same groups as in offshore spills. In addition, slicks are “Likely” to expose nearby shorebirds to oil. There is also an increased risk to benthic species because oil mixed into the water column could expose the benthos, plus oil that strands on nearby shorelines may be remobilized and settle in nearshore subtidal areas. If burning is used to remove oil the changes in risk are similar to those in the offshore, with the exception that there is a slightly increased risk of exposure of shorebirds and terrestrial mammals to soot and burn gases.
- The nearshore, ice-infested environments, include the biologically active areas of landfast ice and the “transition” zone. The unburned slicks from spills pose risks to the same groups as in offshore spills. Subsea blowouts are not likely in shallow nearshore areas where drilling would involve construction of artificial islands. This means that there is little risk to the epontic community from this source. If the oil is not fully cleaned up it may pose an exposure risk to the nearby shorebirds and may strand on nearby shorelines after breakup, be remobilized and settle in nearshore subtidal areas. If burning is used to remove oil the

changes in risk are similar to those in the offshore, with the exception that there is a slightly increased risk of exposure of shorebirds and terrestrial mammals to soot and burn gases.

Risks from the CSM models are summarized in **Table 9-8**. Obviously, great care must be taken in interpreting results from this type of analysis. However, the analysis shows that in all environments burning reduces the number of ecological receptors “Likely” to be exposed to oil, while increasing slightly the number “Possibly” exposed.

9.5.2 Chemicals of Concern for Ecological Risk Evaluation

Oil and burn products pose both physically toxic and chemically toxic risks to biota. The physically toxic are relatively simple and well understood, but comparative toxic risks from chemicals in unburned and burned oil are more complex and are discussed here.

The potentially toxic constituents of crude oil, its residues and combustion products are similar to those of concern for human health. Of the many compounds and elements present in crude oil (**Table 9-1**), two classes of chemicals, PAHs and metals (nickel and vanadium), are considered more toxic to ecological receptors than the alkanes, cycloalkanes or the lower molecular weight aromatics (e.g., benzene, xylene). However, both the PAHs and metals are in relatively low concentrations in crude oil and are not in a form that is readily bioavailable to ecological receptors and so pose only a modest toxicity risk.

On the other hand, several of the individual PAHs are recognized as potent carcinogens, while others can adversely affect survival and growth of organisms. PAHs vary widely in their toxicity to aquatic organisms, with toxicity generally increasing with increased molecular weight (Eisler, 1987). Individual PAHs are in low concentrations in crude oil and have limited mobility in an aquatic setting. Although there can be approximately 15 to 30 percent aromatic hydrocarbons in crude oil (**Table 9-1**), most of these aromatics are comprised of lighter weight benzenes and naphthalenes (**Table 9-3**). Recognized carcinogenic or toxic PAHs such as benzo[a]pyrene and pyrene are typically found at concentrations less than 5 mg/kg (**Table 9-3**). Low concentrations of the lighter PAHs can be found in water beneath oil spills, but as discussed earlier most PAHs have low solubility in water and high partition coefficients ($K_{o/w}$) that limit the mobility of PAHs from oil into the water. **Table 9-9** lists the solubilities and Log $K_{o/w}$ for some of the PAHs found in crude oil.

Table 9-9: Solubilities and Partition Coefficients for Polynuclear Aromatic Hydrocarbons		
PAH Naphthalene	Solubility in Water (mg/L) 31	Log $K_{o/w}$ Values 3.4
Pyrene	0.13	5.3
Anthracene	0.06	4.4
Benzo[a]anthracene	0.014	5.6
Benzo[a]pyrene	0.004	6.0
Benzo[g,h,i]perylene	0.0003	7.2
Sources: Eisler (1987); Varanasi (1989); and Callahan <i>et al.</i> (1979).		

An example of the limited mobility can be illustrated for benzo[a]pyrene. This PAH has a reported concentration of 2.8 mg/kg in Kuwait crude oil (Table 9-1). The $K_{o/w}$ for benzo[a]pyrene is $K_{o/w} = 1 \times 10^6$ (Log $K_{o/w} = 6.0$), which means:

$$K_{o/w} = \frac{\text{concentration of B[a]P in oil}}{\text{concentration of B[a]P in water}} = 1 \times 10^6$$

The equilibrium concentration of benzo[a]pyrene in the water phase in an oil water mixture could be estimated to be:

$$\text{Concentration of Benzo[a]pyrene in water} = \frac{\text{concentration of Benzo[a]pyrene in oil}}{K_{o/w}} = 2.8 \times 10^{-6}$$

Therefore, the concentration of benzo[a]pyrene in water immediately beneath an oil slick might be as much as 2.8×10^{-6} mg/L (2.8×10^{-6} ppm). This is four orders of magnitude less than the concentration of benzo[a]pyrene reported by Neff (1979) as toxic (LC_{50}) to the sandworm (*Neanthes arenceodentata*). An LC_{50} is the concentration that is lethal to 50 percent of the test organisms.

For pyrene (4.5 mg/kg in crude oil; Log $K_{o/w}$ of 5.3), the highest concentration expected in water directly beneath a spill would be 2.3×10^{-5} mg/L (2.3×10^{-5} ppm). No aquatic toxicity data were found for pyrene in a review of applicable toxicity summaries (Eisler, 1987; U.S. EPA, 1980); however, the expected pyrene concentration is three orders of magnitude lower than the lowest toxic concentration listed in Eisler (1987) (50 μ g/L for a copepod [zooplankton] exposed to naphthalene).

For naphthalene, the PAH with the lowest Log $K_{o/w}$ (3.4), the highest concentration expected in water directly beneath a spill having 400 mg/kg naphthalene would be 0.16 mg/L. This concentration of naphthalene may be toxic to zooplankton (depending on exposure duration and other factors) but would not be toxic to fish or shellfish, which have toxicities (LC_{50} s) of 0.92 mg/L for pink salmon to 150 mg/L for mosquito fish (Eisler, 1987).

The primary metals found in crude oil, nickel and vanadium, are found in concentrations of 1 to 20 mg/kg, but may be present at concentrations up to 200 mg/kg nickel and 1,200 mg/kg vanadium in some crude oils (WHO, 1989). These metals occur primarily as organometallic complexes known as porphyrins (Costantinides & Arich, 1967) which can be distilled at temperatures above 500°C (WHO 1989), and are therefore stable at ambient temperatures. Because these metals are complex in porphyrins, they are unlikely to represent a risk to ecological receptors.

Because PAHs and metals in crude oil are in low concentrations and have limited bioavailability in water, the risk to ecological receptors is likely more closely related to the probability of direct exposure to oil and its physical and cumulative toxic effects than to the individual chemicals found in the oil. As discussed in Chapter 7, one of the most important toxic effects of oil on birds and marine mammals is fouling of feathers and fur (Freedman, 1989). This fouling causes a loss of the properties of insulation and buoyancy and leads to death by drowning or extreme

heat loss (hypothermia). Sea otters and other furred marine mammals are especially vulnerable to oil spills because of their reliance on fur rather than blubber for insulation (Stoker, 1992). Birds and marine mammals can also suffer toxic effects by ingesting or inhaling oil while in direct contact with the spill or during attempts to clean feathers or fur by preening. There continues to be long-term chronic effects in fish and waterfowl resulting from direct contact with oil spilled from the *Exxon Valdez* as reviewed by Schneider (1993).

9.5.3 Relative Risk Evaluation

The relative risk evaluation discusses whether burning or not burning spilled crude oil presents fewer risks to ecological receptors in the offshore and nearshore environments whether infested with ice or ice-free. Because the relative risks to ecological receptors is more directly related to the probability of direct exposure to crude oil and its constituents than to the individual compounds in the oil, the results of the risk evaluation closely parallel those of the exposure evaluation:

- Because burning a targeted crude oil slick reduces the volume of oil on the sea by 75 percent or more, the overall probability of ecological risk is substantially less for burn residue than for the spilled oil in all marine environments.
- The burning of crude oil results in production of a modest amount of burn gas and soot, which can pose a toxic risk to wildlife in the very immediate vicinity of the burn. However, this risk is localized to the immediate vicinity of the burn and is very short-live and as such is very small compared to the risk from the oil being burned.

It appears, based on the results of the ecological risk evaluation that under all conditions considered, the preferred decision would be to burn a crude oil spill rather than not to burn.

9.6 Human and Ecological Factors Important to a Burn/No- Burn Decision

Burning spilled crude oil may be appropriate if the potential human and environmental impacts of burning are judged to be less than those of the unburned slick. Evaluating the potential impacts of leaving the oil unburned and of burning the oil, and comparing the overall effects is the logical approach for making a burn/no-burn decision.

Estimates of impact are based on the fate of unburned oil and the products of burning, the distribution of resources, and the sensitivities of those resources to unburned oil and to burning. The foregoing risk evaluations were conducted to assist in estimating the sensitivity of resources, and characterizing the potential impact on those resources resulting from burning or from unburned oil. Conclusions from those evaluations provide factors that are important to making a burn/no-burn decision.

The human health risk evaluation identifies the following factors that need to be considered in making a burn/no-burn decision:

9.6.1 Health Risks from Unburned Oil Spills

- Oil spills, even large spills, rarely pose major health risks to nearby people. The most probable route of exposure to humans is through inhalation of hydrocarbon vapour, although this only rarely leads to detectable effects on humans. Ingestion of contaminated seafood and ingestion of contaminated drinking water (in fresh water spills) may be of

concern in some instances. These health risks can be reduced by burning but only at the cost of incurring other risks.

9.6.2 *Health Risks from Exposure to PM in Burn Emissions*

- It is apparent from observations and from results of air quality modelling that high concentrations of particulate matter can occur within several hundred metres of a burn location. Exposure to high concentrations of PM one or two kilometres from the burn can have acute respiratory effects and exacerbate existing ailments. Measures to prevent human exposures to smoke may be required if a burn is conducted one or two kilometres from a downwind population center. "Safe distances" will depend on the size of the burn.

9.6.3 *Health Risks from Toxic and Carcinogenic Compounds in Burn Emissions*

- The potential cancer risk level and noncarcinogenic hazard index associated with exposure to PAHs and dioxins in burn emissions are below levels of concern. This suggests that adverse health effects from toxic and carcinogenic constituents of smoke are not significant factors in making a burn/no-burn decision.

The ecological risk evaluation identifies the following factors that need to be considered in making a burn/no-burn decision:

9.6.4 *Risk Associated with Burn Residue*

- The overall ecological risk is substantially less for burn residue than for the unburned oil in offshore or nearshore waters or when oil is trapped in broken ice because burning substantially reduces the volume of oil on the sea surface and eliminates most of the toxic components from the residue. The argument in favour of burning is possibly strongest when relatively fresh oil is trapped in broken ice because under some circumstances when spilled oil is contained in broken ice its spreading and dissipation are slowed and persistence increased, thereby increasing the risk to biota that inhabit ice or ice-edge environments. Burning all but eliminates the oil and reduces the toxicity of the residue.
- There is a risk of residue sinking if the parent crude oil is relatively dense. However, because burn residue is depleted in the LMW toxic compounds, it is not acutely toxic. Also, the risk posed by the small amount of HMW aromatic HCs are limited as well because the residue is depleted in these as well, and their bioavailability from the residue appears to be limited.

9.6.5 *Risks from Oil Burning*

- The smoke plume may pose some risk to birds in flight near the burn, but this risk is very temporary and the area involved is relatively small.

In short, this evaluation supports the view that in almost all circumstances burning crude oil on water reduces the potential risks to humans and the environment, compared with leaving the same oil unburned.

References to Chapter 9

- Allen, A.A. and Ferek, R. 1993. **Advantages and Disadvantages of Burning Spilled Oil**. In: *Proceedings of the 1993 Oil Spill Conference*, March 29-April 1, Tampa, FL. American Petroleum Institute, Washington, DC, U.S., pp. 765-772.
- American Cancer Society. 1990. **Cancer Facts & Figures - 1990**. American Cancer Society. Atlanta, GA, U.S.
- Aurell, J. and B. Gullett. 2010. **Aerostat Sampling of PCDD/PCDF Emissions from the Gulf Oil Spill In Situ Burns**. *Environ. Sci. Technol.*, 2010, 44(24):9431-9437.
- Benner, Jr., B.A., N.P. Bryner, S.A. Wise, G.W. Mulholland, R.C. Lao, and M.F. Fingas. 1990. **Polynuclear aromatic hydrocarbon emissions from the combustion of crude oil on water**. *Environ. Sci. Technol.*, 24(9):1418-1427.
- Benner, B.A., N.P. Bryner, S.A. Wise, G.W. Mulholland, D.D. Evans, M.F. Fingas, and K. Li. 1991. **Emissions of polynuclear aromatic hydrocarbons from the combustion of crude oil on water**. *Spill Technology Newsletter*, 16(1).
- Buist, I.A., S.L. Ross, B.K. Trudel, E. Taylor, T.G. Campbell, P.A. Westphal, M.R. Meyers, G.S. Ronzio, A.A. Allen, A.B. Nordvik. 1994. **The Science, Technology, and Effects of Controlled Burning of Oil Spills at Sea**. MSRC Technical Report Series 94-013. Marine Spill Response Corporation, Washington, DC, U.S.
- Constantinides, G. and G. Arich. 1967. **Non-Hydrocarbon Compounds in Petroleum**. In: 1989 World Health Organization (WHO), Copenhagen, Denmark.
- Eisler, R. 1987. **Polynuclear Aromatic Hydrocarbon Hazards to Fish, Wildlife, and Invertebrates: A Synoptic Review**. U.S. Fish & Wildlife Service. Biological Report 85(1.11).
- Evans, D., G. Mulholland, D. Gross, H. Baum, and K. Saito. 1989. **Generation and dispersal of smoke from oil spill combustion**. In: *Proceedings of the 1989 Oil Spill Conference*, February 13-16, San Antonio, TX. American Petroleum Institute, Washington, DC, U.S., pp. 181-186.
- Falk, H.L., P. Kotin, and S. Thompson. 1964. **Inhibition of carcinogenesis: The effect of polynuclear hydrocarbons and related compounds**. *Arch. Environ. Health*, 9:169-179.
- Fingas, M.F., K. Li, F. Ackerman, P.R. Campagna, R.D. Turpin, S.J. Getty, M.P. Soleki, M.J. Trespalacios, J. Pare, M.C. Fissonette, and E.J. Tennyson. 1993. **Emissions from Mesoscale in-situ oil fires: The Mobile 1991 and 1992 tests**. In: *Proceedings of the Sixteenth Arctic and Marine Oilspill Program (AMOP) Technical Seminar*, June 7-9, Calgary, AB. Environment Canada, Ottawa, ON, Canada, pp. 749-821.
- Freedman, B. 1989. **Environmental Ecology - The Impacts of Pollution and Other Stresses on Ecosystem Structure and Function**. Academic Press, San Diego, CA.
- Laskin, S.M., M. Kushner, and R.T. Drew. 1970. **Studies in Pulmonary Carcinogenesis**. M.G. Hanna et al., (Eds.); Inhalation Carcinogenesis. AEC Symposium Series No. 18. U.S. Atomic Energy Commission, Washington, DC, U.S.
- Middlebrook, A.M., D.M. Murphy, R. Ahmadov, E.L. Atlas, R. Bahreini, D.R. Blake, J. Brioude, J.A. de Gouw, F.C. Fehsenfeld, G.J. Frost, J.S. Holloway, D.A. Lack, J.M. Langridge, R.A. Lueb, S.A. McKeen, J.F. Meagher, S. Meinardi, J.A. Neuman, J.B. Nowak, D.D. Parrish, J. Peischl, A.E. Perring, I.B. Pollack, J.M. Roberts, T.B. Ryerson, J.P. Schwarz, J.R. Spackman, C. Warneke, and A.R. Ravishankara. 2012. **Air quality implications of the Deepwater Horizon oil spill**. *Proc Natl Acad Sci U S A.*, 2012, Jan 5.
- National Academy of Sciences (NAS). 1972. **Biologic Effects of Atmospheric Pollutants: Particulate Polynuclear Organic Matter**. Washington, DC, U.S.
- Neff, J.M. and J.W. Anderson. 1981. **Response of Marine Animals to Petroleum and Specific Petroleum Hydrocarbons**. Halsted Press, New York, NY, U.S.
- Raloff, J. 1993. **Burning Issues: Is Torching the Most Benign Way to Clear Oil Spilled at Sea?** *Science News*, 144(14):220-223.
- Schaum, J., M. Cohen, S. Perry, R. Artz, R. Draxler, J. Frithsen, D. Heist, M. Lorber, and L. Phillips. 2010. **Screening Level Assessment of Risks Due to Dioxin Emissions from Burning Oil from the BP Deepwater Horizon Gulf of Mexico Spill**. *Environ. Sci. Technol.* 2010, 44:9383-9389.

- Schneider, D. 1993. **Alaska's Unsound Salmon Fishery**. *Pacific Fishing* (June):36-39, 42.
- Stoker, S.W. 1992. **Biological Conditins in Prince William Sound, Alaska: Following the Valdez oil spill, 1989-1992**. Woodward-Clyde Consultants, University of Virginia, 116 p.
- Tebbens, B.D., J.F. Thomas, and M. Mukai. 1966. **Fate of Arenes Incorporated with Airborne Soot**. *Amer. Ind. Hyg. Assoc. J.*, 27:415-422.
- Thomas, J.F., M. Mukai, and B.D. Tebbens. 1968. **Fate of Airborne Benzo(A)Pyrene**. *Environ. Sci. Tech.*, 2:33-39.
- U.S. Environmental Protection Agency (U.S. EPA). 1989a. **Risk Assessment Guidance for Superfund. Volume 1: Human Health Evaluation Manual**. EPA/540/1-89/002.
- U.S. Environmental Protection Agency (U.S. EPA). 1989b. **Exposure Factors Handbook**. EPA 600/8-89/043.
- U.S. Environmental Protection Agency (U.S. EPA). 1991a. **Human Health Evaluation Manual, Supplemental Guidance: "Standard Default Exposure Factors."** OSWER Directive.
- U.S. Environmental Protection Agency (U.S. EPA). 1991b. **Role of the Baseline Risk Assessment in Superfund Remedy Selection Decisions**. OSWER Directive 9355.0-30.
- U.S. Environmental Protection Agency (U.S. EPA). 1993. **Health Effects Assessment Summary Tables (HEAST)**. Environmental Criteria and Assessment Office. Cincinnati, OH, U.S.
- U.S. Environmental Protection Agency (U.S. EPA). 1994. **Estimating Exposure to Dioxin-Like Compounds. Volume III. Site-Specific Assessment Procedures**. Review Draft. EPA/600/600-88/005Cc. U.S. Environmental Protection Agency, Washington, DC, U.S.
- U.S. Environmental Protection Agency (U.S. EPA). 2005. **Human Health Risk Assessment Protocol (HHRAP) for Hazardous Waste Combustion Facilities, Final**. EPA/530/R-05/006., U.S. Environmental Protection Agency, Washington, DC, U.S.
- U.S. Environmental Protection Agency (U.S. EPA). **Integrated Risk Information System (IRIS)**. On-line database.
- Walton, W.O., D.O. Evans, K.D. McGrattan, H.R Baum, W.H. Twilley, D. Madrzykowski, A.D. Putorti, RG. Rehm, H. Koseki, and E.J. Tennyson. 1993. **In Situ Burning of Oil Spills: Mesoscale Experiments and Analysis**. In: *Proceedings of the Sixteenth Arctic and Marine Oilspill Program (AMOP) Technical Seminar*, June 7-9, Calgary, AB. Environment Canada, Ottawa, ON, Canada, pp. 679-734.
- World Health Organization (WHO). 1989. **IARC Monographs on the Evaluation of Carcinogenic Risks to Humans. Occupational Exposures in Petroleum Refining: Crude Oil and Major Petroleum Fuels**. International Agency for Research on Cancer. Vol. 45. Lyon, France.

CHAPTER 10. OPERATIONAL CONSIDERATIONS

10.1 Introduction

This chapter summarizes the issues and criteria for planning and implementing a safe and effective burn of spilled oil at sea in ice-affected waters. These are considered within the context of the following categories:

- The feasibility of burning;
- The resources necessary to carry out a successful burn; and
- Avoiding or minimizing health risks and environmental impacts.

It should be recognized that operational experience with controlled in situ burning in open-water conditions is somewhat limited. Prior to its extensive use during the DHW response in situ burning had been used only once in an offshore setting, when it was used on a trial basis at the *Exxon Valdez* spill. Experience with in situ burning as a technique in ice-affected waters has mainly been gained from field experiments which, by their nature, are generally of limited size. Thus, many of the suggested techniques in this chapter have been extrapolated from knowledge gained from small tests of in situ burning or derived from experience with conventional spill containment operations.

Many of the ideas in this chapter were taken directly from or were inspired by: the “Burn Plan Approval Check List” developed in 1991 by the Alaska Regional Response Team and refined in 2008, and the *“In Situ Burning Field Operations Manual: 3M Fire Boom”* published by 3M Ceramics Materials Department in 1992, and the USCG [In Situ Burning Manual](#) published in 2003.

As noted earlier in this report, Arctic spill scenarios could potentially include conditions ranging from open water, various concentrations of drift ice, and solid or near-solid ice cover. In situ burning has a potential role in each of these situations with tactics selected to suit the specifics of the scenario, as discussed below.

The following includes reference to the use of chemical herding agents for potential use in enhancing and maintaining slick thicknesses for effective burning. At present, their use still requires additional work relating to their method of application as well as to their regulatory approval. As such they are not considered to be an operational tool and are not included in the operational guidelines.

10.2 Feasibility of Burning

There are basic constraints to be considered in determining the feasibility of burning a particular spill. These include the type and condition of the oil to be ignited, the environmental conditions at the time of the spill, and the location and availability of the equipment and trained personnel needed to conduct the burn. The practicality of burning will also depend on the influence of burning on other activities such as spill source control measures, personnel evacuation efforts, and other spill or shoreline cleanup activities. The acceptability of burning will depend on the location of the oil relative to populations, facilities, and natural resources that could be adversely affected by the burn or burn by-products. These factors that relate to

the feasibility and acceptability of a burn operation will be discussed in turn. Whenever possible the subject is addressed in quantitative terms.

10.2.1 Oil Type and Condition

Most freshly spilled petroleum oils will burn on water. The key parameter that controls the efficiency of in situ burning is oil slick thickness. Slicks, once ignited, will burn until the thickness of the underlying oil reaches about 1-mm. The oil removal efficiency is thus proportional to the thickness of the slick at ignition.

During the early stages of a batch spill, thick slicks of fresh oil are usually available for burning; however, depending on wind, ice and sea conditions, the flow rate at the source, and the spreading characteristics of the oil, suitable thicknesses for burning may only exist over small areas. During large spills with relatively calm conditions and spread-resistant oils (e.g., the first few days of the *Exxon Valdez* spill), combustible layers could extend over large areas.

For ignition to occur the heat supplied by the ignition source must be sufficient to raise the temperature of the slick surface to that greater than the oil's fire point. For this to occur, the slick must be thick enough to insulate itself from the underlying water: > 2 to 3-mm for weathered crude oils and lighter fuel oils; > 5-mm for light (30% water) emulsions; and > 10-mm for residual fuel oils. Once ignition takes place, sustained burning of the slick requires that sufficient heat be radiated to the slick to maintain the slick at temperatures above the oil's fire point. Once about one square metre of slick is on fire the burn will usually be underway.

In order for in situ burning to result in high removal rates and efficiencies the flames must spread to cover as much of the slick surface as possible. Flame spreading is generally accomplished by radiation from the burning part of the slick warming adjacent oil to a temperature above its fire point, allowing the flame to ignite the resulting vapours. As well, the differential heating of the slick by the flames can cause hot oil from the fire zone to spread out over unignited portions of the slick. In either case the rate of flame spreading is a strong function of oil weathering processes. For example, as evaporation progresses the remaining oil's fire point increases; this results in a greater heat demand for ignition and thus slower flame spreading. As well, the increase in oil viscosity due to evaporative losses (or emulsification) reduces flame spreading by increasing resistance to surface-tension flow of hot oil over cold oil.

In addition to evaporation, water-in-oil emulsification greatly affects the feasibility of in situ burning. Experimental burns with certain oils emulsified with 50% water or more have shown that effective in situ burning may be feasible. On the other hand, other oils with as little as 10% to 20% water have been extremely difficult to ignite with conventional ignition systems. In any case, the formation of water-in-oil emulsions generally hampers flame spreading by raising both fire points and slick viscosities. Without specific knowledge of a given oil's burning characteristics based on laboratory testing, it should be assumed that any oil that has become emulsified to levels of 25% water or more will be difficult to ignite; any oil emulsified to levels in excess of 50% water should be assumed to be unignitable. Any successful ignition of emulsions may require relatively calm conditions and the use of ignition techniques that can produce sufficient heat to break the emulsion, volatilise the oil and promote flame spreading. A single ignition point may not be sufficient. Also, it may be necessary to enhance the situation by: 1) increasing the dosage of the igniting material onto the emulsion, thus creating a larger initial ignition area; 2) adding special ignition promoters to the igniting mixture; or 3) applying a primer, emulsion breaker or wicking agent to the oil before attempting ignition. The success of

ignition and subsequent spread of fire for sustained combustion may also be enhanced by initiating the ignition at the upwind region of oil to be burned. Wind effects can be reduced adjacent to the leeward side of fire boom or an ice edge; flame spreading can be increased by the wind; and, ignition can be conducted more safely as vapours from the oil are moved by the wind away from personnel conducting the ignition.

Any decision to burn spilled oil should include an assessment of the ease with which burning can be achieved with the type and condition of oil involved. It may be advisable in certain cases to collect samples of the spilled oil to assist in an assessment of the oil's ignitability and to support post-burn analysis of the operation. Prior to any burn effort, operators may be requested by regulators to conduct a limited test burn on a portion of the spill at an approved location safely removed from the spill source and any major oil slicks. It must be remembered that there may be only a limited time window in which in situ burning can be initiated; the conduct of test burns and their subsequent review can use up valuable operational time.

In ice conditions, the window-of-opportunity is greatly extended compared with open-water conditions. For spills under ice during freeze-up or in winter, the oil can remain burnable for many months, until it appears on the ice surface the following spring. Spills in close pack ice will be ignitable for days longer than the equivalent spill in open water. Spills in loose drift ice will likely have a window of opportunity for burning similar to open-water conditions.

Summarized below are the parameters related to oil type and condition that should be addressed in assessing the feasibility of a particular in situ burn:

- Type of product or crude oil released;
- Emulsion formation tendency and stability of released product;
- Estimated volume of release and estimated volumes that could still be released;
- Estimated spill area (thick and thin portions) and estimated thickness of thick parts of the slick;
- Estimated emulsification of oil in thick slick at 12, 24 and 48-hours;
- Estimated evaporation rate of oil in thick slick at 12, 24 and 48-hours;
- Estimated natural dispersion losses at 12, 24, and 48-hours; and,
- Estimated ignitability of oil in thick slick.

10.2.2 *Slick thickness*

A fundamental issue for successful in situ burning is that the slick be a thickness of at least a millimetre or two, depending on oil type and condition, both initially and throughout the burn. The thickness of the slick is the most important variable for successful ignition and effective burning as it insulates the surface oil from the relatively cold water, and allows the oil to be heated such that it produces vapours that can be ignited and that will burn. Eventually, as the slick thins, the insulation effect will be reduced and the burn will extinguish.

For spills in open water, this will generally mean that oil must be artificially contained with the use of fire-resistant booms. The most direct approach for this would involve a two-vessel deployment, each vessel towing an end of a boom in a U-configuration. The configuration could be towed into the wind/surface current or with the current, the latter approach being favored when the vessels involved cannot manage slow-speed towing. Towing of the boom with the wind can also reduce the turbulent wind-induced and boom-reflected waves within the containment area, providing a calmer surface with less splash-over and emulsification of the

contained oil. An additional tactic that may be considered is the use of conventional booms to concentrate oil and release it into a fire-boom system for burning. As discussed later in this chapter, this tactic was not particularly successful during the DWH response. This was due mainly to the inability of the vessels-of-opportunity to tow booms at speeds less than 1-knot. This tactic has been used successfully and does merit consideration when appropriate vessels are available.

For spills in ice-affected waters, strategies for achieving and/or maintaining an adequate slick thickness will depend on pack ice concentration. In less than 3/10ths ice, oil spreading is not greatly reduced compared with open water, so some sort of containment will be necessary to thicken the oil for burning. Conventional or fire-resistant booms can be used to thicken oil, but if the ice is greater than trace amounts, brash and small floes will accumulate quickly and may limit booming and burning effectiveness. In greater ice concentrations, 3 to 7/10ths, oil spreading will be slowed by the ice, so it may be possible to burn oil just using the containment effects of the ice. More likely, some form of artificial containment will be necessary: booms will not be applicable in this situation, so chemical herding agents could be considered. In greater than 7/10ths, or for oil spilled on ice or present in melt pools, oil will be largely prevented from spreading, and if the slick is thick enough initially, effective burns will be possible.

Table 10-1: Summary of tactics for a range of ice conditions	
0 to 3 tenths	<ul style="list-style-type: none"> • Oil spread and movement not affected much by ice • Use fire-resistant booms in trace ice (<1/10th), but in 1 to 3/10ths booms will tend to accumulate brash ice and small floes rapidly • Consider using herding agents
3 to 7 tenths	<ul style="list-style-type: none"> • Oil spread slowed by ice pieces • Difficult to manoeuvre booms • Attempt uncontained burning of thick slicks • Use herding agents to thicken slicks if necessary
7 to 9+ tenths	<ul style="list-style-type: none"> • Floes touching, oil essentially contained • Thick slicks relatively easy to burn • Use herding agents to thicken slicks if necessary

For spills involving oil released into or under growing solid ice (i.e., landfast ice or large floes) the oil will be encapsulated in the ice sheet and appear the following spring. Experience has shown that the oil, once exposed on the surface, will accumulate in melt pools and be herded by the wind to thicknesses of approximately 10-mm against the downwind edge. Oil released on solid ice will spread somewhat, but will be absorbed by snow and pool in natural depressions in the ice surface. This oil could be ignited as soon as it is located.

10.2.3 Environmental Constraints

Temperature, wind, currents, and waves promote various physical and chemical changes to a spill that can make the oil difficult or impossible to ignite. High temperatures and winds result in the rapid loss of volatile components and reduction of film thickness. High wind and sea states can increase the rate of emulsion formation and the rate of heat transfer through the slick, both of which reduce ignitability.

In evaluating burn feasibility, aerial or surface observations need to be made to assess the spreading, transport and weathering effects of the environment on the spill. The assessment should also include the effects of wind, sea, and ice conditions on the use of igniters and fire-resistant booms if they are to be utilized, as well as on all necessary support operations. As with physical recovery approaches, excessive winds, waves, currents or debris can make it difficult or impossible to collect and hold the oil. In situations where burning is being considered in an uncontained mode (i.e., without the use of fire-resistant booms) it is even more important to take into account the spreading and weathering of the surface oil due to wind, ice and wave conditions.

Although there is little data on the effects of sea state on in situ burning, experience suggests that the sea-state limit for effective burning is from 1 to 1.2-m wave height or less. Also, if the fire-resistant boom fails to hold oil in during any of these sea state conditions, burning would not be practical. In pack ice conditions, the presence of ice floes tends to dampen waves, possibly enhancing the burning of oil in open areas between such floes.

Winds of approximately 30 to 40 km/h (15 to 20-knots) are considered to be the upper limit for ignition of oil pools in the absence of waves. These constraints reflect both the current state-of-the-art in proven ignition and fire-resistant booms systems, as well as the environmental conditions under which most oils will be quickly weathered (i.e., emulsified) beyond a combustible state in open water. Again, the presence of pack ice may greatly extend the window-of-opportunity for igniting spilled oil in situ. Oil encapsulated in ice will not weather significantly, until it is released on to the surface of the ice the following spring.

Another important environmental factor favoring burning is good visibility. For a safe and effective burn to take place with fire-resistant boom or in pack ice with, or without, herders it should be possible to see: 1) the oil to be collected, 2) the vessels towing the fire-resistant booms, and 3) the proximity of the intended burn location relative to the spill source, other vessels in the area, and other potentially ignitable slicks. As a guide, visual flight rules (VFR) flying conditions (greater than 4-km visibility and a minimum 300-m ceiling) could be used. If helicopters are to be used, VFR flying conditions must exist both at the site and at the helicopter base. If burning is to be conducted at a remote, fixed, continuous source of spilled oil (e.g., an offshore blowout), it may be feasible to burn spilled oil safely at or near the source during limited visibility conditions (e.g., less than VFR flying conditions, dusk, dawn, etc.). As discussed in the following section, such burning may not be practical if the source of oil is not burning since flames could ignite oil or vapours in close proximity to the source. In Arctic areas, daylight is often extremely limited in the winter months, but exists for 24 hours per day in the summer months. Large springtime in situ burning operations to ignite oil on melt pools must factor in the availability of VFR flying conditions in the window of time between when the oil begins to appear on the ice surface and when the ice sheet candles, breaks up, and dissipates.

The environmental conditions that should be assessed prior to conducting an in situ burn are summarized below:

- Wind speed at site and forecast for next 12, 24, and 48-hours;
- Sea state and ice conditions at site and forecast for next 12, 24, and 48-hours;
- Visibility (VFR flying conditions) at site and forecast for next 12, 24, and 48-hours;
- Speed and direction of residual current and pack ice drift;
- Tidal current forecast over next 48-hours;
- Weather conditions and forecast for next 12, 24, and 48-hours; and,

- Sea temperatures and water depths in area in relationship to vessel operations.

10.2.4 *Compatibility with other Response Activities*

Attempts to burn oil during a spill response should not interfere with other critical operations such as the stabilization and control of the spill source or the evacuation of personnel from a stricken vessel or platform and any other operations being conducted at the site. Also important to understand is the influence burning might have on other spill control activities such as mechanical skimming, the application of chemical dispersants, and the protection and cleanup of shorelines. The following summaries for the above response activities need to be considered prior to and during a burn operation.

10.2.4.1 *Stabilization of spill source:*

During the early hours of a major spill, or for the duration of a spill from an offshore platform, there may be attempts to seal leakage points, transfer oil from one compartment to another, reduce the potential for a fire or explosion at the spill site and conduct well control operations. There may also be efforts underway to move the source of spillage to a new location where the source or its release of oil can be better controlled. At the same time there may be a decision to keep essential personnel onboard. In each of these situations, it is imperative that the stricken ship or platform be protected from fire and explosion hazards. Under such conditions the use of controlled burning on any portion of the spill should only be considered if and when all responsible parties are confident that the burn can be accomplished with no possibility of endangering property and personnel

10.2.4.2 *Evacuation of personnel:*

During an accidental oil spill there may be a need to evacuate personnel from the immediate area. When evacuation efforts are underway it is important that spill control operations be conducted in a manner that does not impede the evacuation process. Any attempt to burn spilled oil should be conducted only if it can be accomplished at a safe, isolated location and if it is certain that the burn will not interfere with the visibility and movement of vessels or aircraft used during the evacuation. It should also be determined that the personnel, vessels and aircraft needed to conduct the burn are not needed for the more important task of transferring personnel from the source to a safe location.

10.2.4.3 *Mechanical cleanup:*

The use of burning in open-water and loose drift-ice conditions should be planned and implemented not necessarily as a response technique to replace mechanical cleanup, but rather as an additional response option to be used where and when it is safe to do so. When the spill source is already ignited it may be appropriate to conduct burning operations as the primary technique near-source with mechanical cleanup as the secondary technique down-stream. In other situations, particularly where there are ample containment and recovery systems, it may be possible to position the skimming equipment closest to the spill source and use controlled burning techniques at a safe distance downstream as a backup to the mechanical systems. Careful attention must be paid in this instance to avoiding flashback. In situ burning could be considered as the primary response technique for spills in pack ice. In fast ice situations, where mechanical recovery operations cannot be implemented safely and effectively, in situ burning could be considered the primary response technique.

Many issues must be considered in coordinating mechanical removal and burning resources at a spill incident and these must be examined for a broad range of specific spill scenarios. Guidelines should be established in advance so that time is not lost comparing options and evaluating trade-offs during an actual spill.

10.2.4.4 *Dispersant application:*

Under the right conditions, dispersants can be used to disperse large quantities of spilled oil from the sea surface. It is considered one of the primary options for response to oil spills, particularly when physical containment techniques or equipment are not practical or available. The use of in situ burning might be appropriate to back up a dispersant operation or vice versa, and these possibilities require examination, again on a scenario-specific basis.

Dispersants and in situ burning both work best on spills involving relatively fresh, non-viscous oils. Again, in joint operations on the same spill, it is important to establish response guidelines well in advance to ensure that one method does not interfere with the other. In particular, burning has the potential for reducing the effectiveness of a dispersant-use operation by affecting the viscosity of oil left on the surface and creating hazardous flying conditions due to smoke. It is thus reasonable to suggest that each operation should focus on separate parts of the spill remote from each other and that ice conditions dictate which takes precedence.

Many spill scenarios can be envisioned in which mechanical, burning, and dispersant systems could be used simultaneously on a major spill at sea. For example, following a sudden “batch” spill that results in the oil coverage of many square kilometres, specific zones could be identified for each mode of response allowing each technique to be used independently and without interference (such as was done at the DWH incident). It could also be possible to use all three response techniques in close proximity to each other immediately downstream of an ongoing continuous spill source. In this case, mechanical systems might concentrate and recover a portion of the oil near the source; fire-resistant booms might be positioned a safe distance downstream of the skimming; and any oil missed by or entrained beneath the fire-resistant booms could then be sprayed with dispersants, again a safe distance downstream. Theoretically, there are many possible scenarios that could involve joint operations. These should be analyzed carefully in contingency planning exercises.

10.2.4.5 *Shoreline protection and cleanup:*

In spill situations where one might consider burning close to shorelines, the appropriateness of such burning would depend on the type of shoreline and the potential ignitability of backshore areas, the existence of human-use facilities, and the performance of any shoreline protection or cleanup activities nearby. Under certain conditions it may be feasible to utilise fire-resistant booms in a deflection mode to support controlled burning against the shoreline. In other situations it may be advisable to use fire-resistant booms in an exclusion mode to prevent burning oil from entering a sensitive area. In any event, burning near or adjacent to a shoreline should never be conducted where there is any chance of starting fires onshore or endangering other shoreline protection and cleanup activities.

The following list summarizes the issues that should be addressed when assessing the implications of in situ burning operations to other spill-related activities:

- Whether the spill source is already ignited and, if so, whether it should be extinguished;
- Location of volatile vapours and direction of movement at and away from the source;

- Status of spill source (abandoned, rescue underway, source control operations underway, etc.);
- Distances and directions to nearby shores;
- Local ice conditions;
- Type of accident (e.g., grounding, collision, transfer spill, blowout);
- Location of burn and smoke with respect to source;
- Location of burn with respect to other slicks;
- Location of burn and smoke with respect to shorelines;
- Location of burn and smoke with respect to countermeasures; and
- Status of other response operations.

10.2.5 Requirement for Regulatory Approvals

Prior to conducting a burn it is necessary to obtain appropriate permits and approvals. This issue is dealt with in the third report in this series. Controlled burns have been approved by Regional Response Teams in the United States for both onshore and offshore spills, but the approval process has been time-consuming. Since the late 1980s there have been several attempts to streamline the approval process and to provide a set of guidelines that could be used by the Incident Commander at a spill. One example is the “checklist” developed by the Alaska Regional Response Team in cooperation with several federal and state agencies.

During an actual spill, a situation may develop where the approval process is still underway as the spilled oil approaches a condition and/or location where it may be impractical or impossible to burn. Under such circumstances, the Incident Commander may elect to mobilize equipment for burning with clear instructions not to ignite any oil until authorization is received. In this way valuable time can be saved by getting vessels, booms and aircraft on location, and by containing oil within booms should the decision to burn be reached. If burning is not approved, it may be possible to initiate a conventional recovery operation on the oil contained within the fire-resistant booms.

10.3 Resources Necessary for a Burn

This section discusses the resources that are normally required to carry out a safe and effective controlled burn: trained personnel, vessels and/or aircraft and igniters and fire-resistant boom (in open water and loose drift ice). It is recognized that certain types of burning may not require all of these resources. For example, a situation involving accidental burning of oil following a ship accident would not require igniters to start the burn process; and, an intentional programme to burn a thick, spill in close pack ice would not involve fire resistant boom.

10.3.1 Trained Personnel

Individuals involved with the planning and implementation of controlled burning of oil at sea should be trained in both the theory and hands-on aspects of contained in situ burning. The amount and focus of the training should reflect the job and level of responsibility assigned to each member of the burn team. Areas of instruction should include:

- Response organization and management, including specific job assignments;
- Government regulations and permitting procedures;

- Communications (specific to command and control interfacing, and vessels and aircraft involved with the burning operations);
- Strategies and priorities for response, including procedures for coordinating with aerial support/spotting operations and other spill control activities;
- Basic combustion theory and fire prevention and control techniques;
- Safe equipment handling procedures (fire-resistant booms, igniters, vessels, etc.);
- Equipment and procedures for the possible recovery and storage of burn residue;
- Personal protection equipment and first aid;
- Backup response strategies (i.e., identification of potential emergency conditions and appropriate response procedures);
- Avoidance and minimization of environmental impacts; and
- Procedures for documenting the size and duration of each burn.

It is important that trained personnel be available on each vessel and aircraft used for the burning operation. Individuals assigned to field-operation positions should be familiar with the deployment and use of fire-resistant boom, aerial and surface ignition systems, and other equipment necessary to carry out a safe and effective burn. Response personnel training should satisfy all OSHA regulations (both federal and state) and they should have received appropriate levels of training in the Hazardous Waste Operations and Emergency Response (HAZWOPER) training programme. (NOTE: As a result of the extensive use of in situ burning during the DWH response, there is an ongoing API-sponsored initiative to identify the training and qualification requirements for ISB responders; the results should be available in 2013.)

It is imperative that all personnel and equipment be protected from any harmful exposure to heat and combustion products. All personnel that could be exposed should be provided with adequate personal protection equipment (such as respirators, safety glasses, and protective clothing) based on the requirements of the response organization in control and/or the regulatory agency for the region involved. Such protective measures would not normally be used since it is relatively easy for response vessels and aircraft to remain well outside any zone of potentially dangerous exposure to heat or combustion products. However, personnel may experience brief exposures due to wind shifts, vessel power failures, and oil and emission sampling activities. Because of these short, though potentially significant exposures, personnel should be trained on how to avoid such conditions and what to do or wear in the event that exposure is unavoidable.

10.3.2 Vessels and Aircraft

Prior to the ignition of spilled oil all vessels and aircraft should be properly selected and positioned in pre-designated safe operating zones. These zones should be identified so that no one could come into contact with harmful concentrations of oil (or combustion products) due to deliberate or accidental ignition. The operation of boom towing vessels must continually take into account the size, thickness and volatility of nearby slicks, as well as vapour clouds that could come into contact with potential ignition sources such as the vessels and the burning oil. All vessels should be equipped with explosimeters.

It is important that all vessels used during offshore burning operations have sufficient power to pull the size and length of fire-resistant boom being considered and be suitable for the ice conditions prevalent. Vessels with twin variable-pitch propellers are generally preferred; and powers in the 100 to 150-kW (150 to 200-hp) range are generally sufficient for boom tow boats.

Large vessels (e.g., 45- to 60-m supply vessels) make ideal platforms for large containment booms and recovery systems, although such vessels are often over-powered for the needs of pulling boom. Experience has shown that small towing boats in the 8 to 12-m range are usually much better for controlling a simple track-down and collection operation, particularly when towing speeds need to be maintained for extended periods at 0.5 m/s (1-knot) and less. This size of towing boat can often be transported to the burn area with a larger vessel and deployed and recovered from the larger vessel. Regardless of the size of vessel selected, it is important that its propulsion system permit the vessel to maintain steerage at speeds in the 0.5 m/s (1-knot) and lower range. Small fishing vessels with trawling gear were found to be very effective at low-speed towing for sustained periods during the DWH response.

Vessels used for the towing of fire-resistant boom need to be equipped with properly positioned tow-posts or bitts and adequate lengths of tow line (typically 100 to 200-m). The tow lines need to be strong enough to accommodate the maximum drag forces that would likely be experienced during the towing of boom in open-water conditions. For example, working with an anticipated maximum drag force of about 11,000 to 13,000 Newtons (N) (2500 to 3000-lbs) and a safety factor of 7, a polypropylene tow line with a 33-mm (1-5/16") diameter would be required. A similar tension strength (i.e., about 93,000-N or 21,000-lbs) could be achieved with the use of a 27-mm (1-1/16 inch) nylon line or a 25-mm (1-inch) polyester line. Buoyant lines are preferred to avoid entanglement with vessel propellers. Tow loads for fire booms operating in drift ice will be approximately twice those in open water.

Vessels should also have space to carry fire-resistant booms to the burn site and space to deploy them. The size and weight of the boom must conform to the deck space and safe load-carrying capacity of each vessel. When the boom-towing boats are too small to carry the entire boom on deck, the fire-resistant booms may be pulled in a straight-line tow (typically at speeds of about 9 to 18 km/h [5 to 10-knots]), or the boom can be transported to the oil collection area with the aid of an additional vessel or barge. In some cases, helicopters may be used to transport short lengths of fire boom from shore or from a vessel to the spill site.

With respect to aerial support operations, helicopters will provide an effective platform not only for the possible transport of boom and personnel, but for the release of igniters onto the oil to be burned. Helicopters will also be of value for the spotting of oil slicks, the directing of vessels to the heaviest concentrations of the spill, and the monitoring of burn effectiveness and smoke plume transport and dispersion. Because of the diversity of tasks for which helicopters may be used and the distances that may have to be travelled offshore, it is important that the type and size of aircraft, the number of engines, and the need for pontoons be properly considered.

For burning operations for oiled melt pools, a large number of helicopter sorties may be required over several weeks, requiring a nearby base of operations for fueling both the helicopters and Heli-torches.

It should be recognized that while aircraft will usually play a key role during burning operations, there will be potential burn situations where controlled burning could be initiated without them. For example, as long as surface operations are located a safe distance from property and other vulnerable resources, boats could begin to concentrate and ignite oil with hand-held igniters released from one of the boom towing vessels.

10.3.3 Fire Booms

From an operational standpoint, it is the specific location and nature of spillage to be contained that will determine the type, size, length and mode of deployment of fire-resistant boom required. The location and nature of the spill, together with the boom deployment mode will then determine the best type of igniter and the most appropriate scheme for igniting the contained oil. It is important to remember that many spill scenarios in ice-affected waters may not require the use of fire-resistant booms for the effective burning of large quantities of spilled oil. In such situations, extra safety precautions may be necessary to avoid unexpectedly large initial burn areas and harmful exposure levels. Also, in remote areas, herding agents may be employed to thicken oil slicks for ignition and burning without the need for booms.

When spilled oil has spread too thin layers covering large areas, fire-resistant boom, or possibly herding agents, will be required to concentrate the oil to thicknesses that will support combustion. Wind may also help by concentrating oil against ice or a shoreline to support combustion. If there is a chance that burning could spread dangerously to oil outside a contained area, the oil should be ignited well away from the main slick. Should a tanker accident or platform release involve spillage without fire, fire-resistant boom could be used to collect oil in one or more U-configurations and then be towed to a safe location for ignition. If oil is already burning at the source, this mode of controlled burning should be considered if it is impractical or unsafe to burn near the stricken vessel or platform.

During burning operations on the leeward or downstream side of an already burning tanker or platform, it may be impossible to deploy fire-resistant booms immediately at the spill source. In such a situation, it may only be necessary to periodically release igniters into any unignited oil as it concentrates under the influence of wind and currents against ice edges in the lee of the burning vessel or platform. If safe to do so, it may be possible to position fire-resistant booms on the leeward side of a vessel or platform and take advantage of the natural ice-free area created, in order to thicken and burn oil before it spreads downstream.

Some fire-resistant booms are heavy and difficult to handle, but are also durable and able to survive burning in an offshore marine environment for long periods. These are typically metal booms. Others are lighter and easier to handle and deploy but are not designed for long-term deployment offshore or long-term exposure to fire. These usually employ fire-resistant, mineral-based fabric and ceramics and in some cases include a water-cooled outer membrane. It is important for planners and field personnel to anticipate the full range of constraints that may be imposed on the burning operation because of a boom's particular weight and handling requirements. With proper training, experience has shown that fire-resistant booms can be deployed quickly and used in the same manner as most comparably sized conventional booms.

When fire-resistant boom is used to contain burning oil, there will almost always be some degree of thermal stress and material degradation with time. Some fire-resistant booms have been constructed of materials designed to strongly resist the effect of fire (e.g., steel). Other fire-resistant boom designs have outer coverings that protect the more fragile underlying material from abrasion during handling and storage, but are destroyed during the early phase of a burn. The underlying materials are refractory in nature and designed to withstand the effects of burning and to remain intact for subsequent burns over a period of several hours. Wave action may accelerate the degradation of these boom types. The actual number of times that a fire-resistant boom can be used will vary from one product to another and from one application to another. Repeated use will clearly depend on the intensity and duration of the

burns, the sea conditions at the time of burning and the manner in which the boom is handled during and between each burn. As with some conventional booms, the extent of use and the degree of damage may make it cost-effective to discard the boom upon completion of use, rather than attempting to clean and restore it.

When using fire-resistant booms for multiple burns, the boom should be inspected (at least along segments exposed to the most thermal stress) for any significant breaks, tears, or deterioration which could result in mechanical failure or loss of containment. Any damaged sections should be repaired or removed and replaced as necessary. If it is necessary to tow used fire-resistant booms of the sacrificial-coating type to a new site for additional burns, care should be taken to avoid any excessive speeds (more than 4 to 8 km/h or 2 to 4-knots) even in a straight-line tow. This is because exposed areas where the protective outer cover has burned away will experience excessive drag and be less resistant to abrasion. Even with metal construction boom, care should be used in transporting and reusing the boom due to the cumulative effects of mechanical and thermal stress upon its components.

10.3.4 Igniters

With respect to igniters, this report describes several devices for igniting spilled oil. Of these, the Heli-torch is one of the most cost-effective, reliable and flexible systems for the aerial application mode. The Heli-torch provides an off-the-shelf ignition system that has been used for many years by forest fire fighting organizations in different parts of the world. Because of the quantity of gelled fuel that can be carried (typically from 100 to 1000-L), it is possible to release ignition fluid (gelled fuel) as individual ignition points in short bursts or in a continuous mode for up to several minutes. Gelled fuel ignition points, typically "fist-sized", fall to the surface and burn for several minutes. With the Heli-torch operated from a hovering position (at altitudes of 8 to 80-m or more), it is possible to create very large initial ignition areas in a continuous mode for difficult-to-ignite weathered or partially emulsified oil layers.

In spill situations where a helicopter's staging area is distant from the proposed burn region, such as in the case of igniting oil on many melt pools from an over-winter spill under pack ice, it may be advisable to locate nearby temporary landing sites where the helicopter could set down between ignitions. A single drum of gelled fuel within the Heli-torch would normally be large enough to support the ignition of numerous individual burns. During an extensive ongoing burn operation it may be helpful to move backup Heli-torches, fuel, mixing facilities and gelling agent to forward landing sites in order to avoid delays because of long transit distances to the primary staging location. Ships or offshore exploration/production platforms with appropriate heli-decks may also be used, if the transport and mixing of the gasoline-based Heli-torch fuel is allowed onboard. One example of this approach would be a large, appropriately-classed icebreaker located in pack ice to support springtime melt pool ignition operations.

10.3.5 Avoidance of Risk to People and Property

Any attempt to ignite and sustain combustion safely, effectively and with minimal disturbance to other spill control operations must include an assessment of the burn location and its proximity to:

- The spill source and vapours drifting from it;
- Other potentially ignitable oil slicks;

- Shorelines, man-made structures, natural areas onshore that could catch fire, population centers, airports, roads, and other areas of human use;
- Sensitive biological resources; and
- Other vessels and ongoing response operations.

If the spill source is not already burning and its ignition is undesirable, it is essential that burning be considered only if it can be accomplished at a safe distance from the spill source and any free-floating, potentially ignitable oil slicks. The safe distance should be confirmed by the use of portable explosimeters to detect flammable vapour concentrations. In calm conditions (winds less than 2 km/h or 1-knot) burning should not be considered in close proximity to a flammable spill source. Under all conditions, consideration must be given to the possibility of wind shifts and the transport of volatile vapours toward operations where accidental ignition could occur.

For a safe in situ burn to take place it is important that the location and timing of ignitions be established and thoroughly understood by all response personnel in the area. It must be possible to identify, and communicate to all responders, those zones that have been selected as acceptable burn areas. It is equally important to identify specific areas where ignition and sustained burning operations will not be permitted. The nature of the spill and its slicks, the weather conditions, and the reliability of communications and spotter aircraft, should all be considered carefully in establishing a well understood and clearly defined burn plan.

In assessing the appropriate time and place for a burn, one must consider the proximity of the intended burn to coastal features, population centers and sensitive natural resources. The potential exposure of human and environmental resources to the effects of burning spilled oil should always be given high priority before the initiation of a burn. The burn must be completed without exposing people, equipment, facilities, forests, tundra and animals to any harmful levels of the products of combustion.

In the event that some unexpected condition (e.g., a wind shift or vessel power failure) requires the early termination of an ongoing burn, personnel must be familiar with the appropriate responses, and there must always be ample vessel manoeuvring room to complete such operations.

The following sections address safety and control measures and possible mitigation techniques that should be considered during every burn.

10.4 Safety and Control Measures

10.4.1 Burn Plan:

A detailed burn plan should be prepared by any response organization intending to use in situ burning as a spill control measure. The plan should include:

- A clear set of objectives for the types and magnitudes of spills that could take place within the area of interest;
- Guidelines and a “checklist” for securing approval to burn;
- An “operational checklist” to ensure that all information needs and resources are identified or in place to conduct a successful burn;
- An “immediate action plan” including response team organization, notification procedures, mobilization guidelines, communications networks, backup logistics support, etc.;

- Specific response procedures for spill scenarios most likely to occur in the area of interest (including equipment deployment, oil collection, ignition, towing during combustion and residue recovery);
- A summary of safety and control measures to minimise risks, protect personnel and facilities and interface with other response activities; and,
- Guidelines for monitoring and documenting burn performance, smoke plume trajectories and environmental impacts.

10.4.2 Training:

All response personnel should meet all OSHA and HAZWOPER requirements (as noted earlier), and take part in annual classroom and hands-on training with an emphasis on the potential effects of burning on personnel, equipment, communities and facilities. Training should include such topics as safe operating practices for vessels and aircraft, fire-resistant boom deployment and towing procedures, oil ignition techniques and burn residue recovery guidelines.

10.4.3 Communications:

Good communications must be maintained prior to and throughout the in situ burning operation. Specific radio links need to be established for all vessels, aircraft and ground-based operations. All personnel on location must be in constant radio contact with the on-site burn supervisor who should have sole responsibility to authorize ignition of a slick. Dedicated radio links should be established for the exclusive use of the boom towing vessels as the operators of those vessels will need to be in frequent contact regarding their position relative to each other, the leading edge of the burning oil, the spill source and other slicks in the area. In the event of loss of radio contact with the burn supervisor during a burn, the lead tow boat should have authority to extinguish the burn if necessary.

10.4.4 Fire Control:

Depending on the nature and magnitude of the proposed burn, a dedicated fire control vessel and team could be established. This team could provide backup support for the monitoring of safety measures and supply additional personnel, booms, igniters and supplies as needed. The fire control team could also assist with the use and maintenance of adequate fire-free zones (or fire breaks) between certain vessels or burning operations, between the spill source and the controlled burn, and between the burning operations and certain facilities or sensitive shorelines. The fire control group could also provide an additional level of protection should it be necessary to assist or relieve a vessel with engine trouble, to watch for other oil slicks in proximity to the burn, and to operate fire monitors or foam dispensers should they be needed.

10.4.5 Aerial Surveillance:

Aerial surveillance using airplanes or helicopters will be highly important in providing an ongoing update on the status of the spill source and the resultant oil slicks. As with mechanical containment and recovery operations, spotter aircraft can provide guidance for surface vessels involved with the location and removal of oil. Aerial observers can keep boom towing vessels apprised of their location relative to fresh, thick oil layers and they can ensure that burns are conducted to minimise interference with other response activities. The maintenance of an aerial surveillance programme will also permit the early detection of any sudden shifts in wind

direction (and resulting smoke plume trajectories), allowing for the warning of any downwind operations or population centers.

10.4.6 *Traffic Control:*

Prior to and during all burning operations, the Incident Commander should ensure that all field activity is coordinated closely with flight regulatory organizations (i.e., the FAA in the U.S.), local airports, and the relevant Coast Guard because burn activities and the products of combustion can affect the movement of vessels and/or aircraft in the general vicinity. It is important that appropriate surface and air traffic control corridors be identified and maintained throughout the spill response.

10.4.7 *Personnel Protection:*

The best form of protection that can be provided for all participants in controlled burning is to keep all vessels and aircraft within pre-designated safe operating zones. The "Burn Plan" for each type of burn scenario should contain specific guidelines as to where boom-towing vessels, support vessels, and aircraft will be permitted to operate prior to, during and following the ignition and burning phases of each burn. A properly conducted burn is one in which all personnel directly involved with the burn are located upwind or at a safe distance side wind of the oil to be ignited. In addition, longer-than-normal tow-line lengths should be used by the boats towing fire-resistant booms. For example, even though 150-m tow lines were used along with a 137-m long fire-resistant boom during the burn conducted on the second day of the *Exxon Valdez* oil spill, personnel on the towing vessels could still feel the heat of the fire. However, even at the peak of intense burning (flames estimated to be greater than 60-m high), the radiated heat level was not uncomfortable. Tow line lengths throughout most of the approximately 400 burns conducted in the DWH response were approximately 100-m in length (Allen *et al.*, 2011).

Once ignited, the size and magnitude of the fire will dictate the extent to which personnel locations can be changed safely during a burn. The use of four fire diameters as the safe approach distance is recommended. This is quite conservative as it does not take into account the effects of clothing and wind cooling on the safe heat flux.

Closer approaches can be made to the edge of the fire for short periods of time. Personnel could safely be within two fire diameters for two minutes.

Radiant heat fluxes necessary to cause charring and ignition of wood would be experienced within one diameter of the center of the fire (0.5 diameters from the edge). Exposed, non-combustible materials such as vessel hulls can become very hot over time near a fire. Because the cooling characteristics of the materials cannot be accurately predicted, care should be taken regarding such surfaces that are exposed to the fire.

Once a burn is initiated, it should be easy for all personnel to see the flames and the smoke plume and to remain outside of the areas of influence. Personnel located on boats or aircraft that could conceivably be in close proximity to the burn or find themselves temporarily in the path of the smoke plume should be equipped with appropriate personal protective equipment. Such protection might include fire resistant outer garments, full-mask or half-mask respirators (with safety goggles) and filters designed to handle particulates as well as organic vapours.

10.5 Recovery of Burn Residue

The amount of unburned oil residue left on completion of a burn is a strong function of the type, nature and amount of oil involved in the burn. During static, contained burns of thick, relatively fresh crude oil, the amount of burn residue may be as little as 1 to 2% of the original oil volume, and as high as 5 to 10%. In cases where the operation is a continuous process of burning oil as it floats into a containment barrier (e.g., downstream of a continuous leak), the percent remaining should be smaller than that from a static burn. In some situations the burn may result in large quantities of original oil remaining unburned. If possible, this unburned oil should be reignited in subsequent burns as additional oil is collected within the fire-resistant booms. While the residue remaining after a burn does not have as much of the lighter volatiles as it started with, efforts should be made, when practical, to collect residue and store it for disposal at a later time. During experimental burns of lighter oils the residue has almost always remained buoyant and of a consistency that could be removed from the water easily with nets, snares and other such manual systems; the use of conventional skimmers on the residue from an efficient burn may not be advisable due to the extremely high viscosity and tackiness of the residue. In some burn situations, for example burning in a towed fire boom, the viscosity and density of the remaining oil could increase to a point where it is entrained beneath the barrier. It is possible that as residue cools from its temperature beneath the fire to the temperature of the surrounding water it could become neutrally buoyant or sink and become unrecoverable.

10.6 Possible Mitigation Efforts

The following are brief descriptions of actions that could be taken to mitigate the effects of an in situ burning operation or to improve its efficiency.

10.6.1 Burn and Plume Location:

One of the most obvious ways to mitigate the potentially harmful influences of smoke products is to conduct the burn under favorable atmospheric circumstances. To the extent feasible, every effort should be made to ensure that the products of combustion are released during periods when the smoke plume is dispersed and transported over unpopulated areas.

10.6.2 Minimization of Burn Time:

Because the oil elimination rate is directly proportional to the burn area, a controlled burning operation can be speeded up by increasing the area of the burn on the water. This is done by carefully slowing down the boats pulling fire-resistant boom in a U-configuration, thereby allowing the oil to spread forward within the boom. It is possible to expand the normal oil surface area (associated with a 0.9 to 1.3 km/h or 1/2 to 3/4-knot towing speed) to an area that is up to two to three times larger. The burn time, therefore, is reduced by a factor of two to three. This may result in larger amounts of burn residue, but the savings in time could be important in freeing up equipment to access more of the spill within the "window of opportunity" for burning. It should be noted that increasing fire area will increase radiant heat fluxes.

10.6.3 Use of Ignition Enhancement Techniques:

The efficiency of ignition and the time for flames to cover the entire slick will affect the overall time required to complete a particular in situ burn operation. Improvements could be realized by including the use of floating wicking agents such as wood chips or hollow glass microspheres

to provide enhanced insulation from the cooling effect of the underlying water and thus allow greater heating for oils of low volatility. Other techniques might involve the use of promoters such as petroleum products or chemicals to increase flame temperatures or to assist flame spreading or the use of de-emulsifiers to help break water-in-oil emulsions.

References to Chapter 10

Allen, A., N. Mabile, D. Costanzo, A. Jaeger. 2011. **The Use of Controlled Burning during the Gulf of Mexico Deepwater Horizon MC-252 Oil Spill Response.** In: *Proceedings of the 2011 International Oil Spill Conference (IOSC)*, May 23-26, Portland, OR. American Petroleum Institute, Washington, DC, U.S.

